



**MARSHALLTOWN
MORE THAN EVER**

**CITY OF MARSHALLTOWN CITY COUNCIL AGENDA
CITY HALL COUNCIL CHAMBERS
10 WEST STATE STREET
MAY 11, 2026, 5:30 PM**

A. CALL TO ORDER

B. PLEDGE OF ALLEGIANCE

C. ROLL CALL

Cahill, Fonseca, Mitchell, Nichols, Schneider, Thompson, Yopez-Gomez

D. PUBLIC COMMENT

Members of the public may make comments on any item that is not on the agenda during this time. The speaker shall approach the microphone and state their name and address. Comments shall be limited to three (3) minutes unless a longer comment is authorized by the Mayor. The speaker shall direct comments to the Mayor and the Council as a whole.

The Mayor and Council may provide a response to a public comment, but shall not engage in discussion or debate on items raised by members of the public. No action may be taken on items raised in public comments to comply with open meeting laws.

E. MAYOR, COUNCIL AND ADMINISTRATOR COMMENTS

1. National Police Week and Dedication of Police Department Employee of the Year

F. CONSENT AGENDA

1. Approve Minutes 04/27/26 Meeting and Bill List \$1,652,931.01
2. Approve Alcohol License Renewals - Tremont on Main, 22-26 West Main Street, Hy-Vee Party Room with outdoor service, 802 South Center Street; Hy-Vee Fast & Fresh, 808 South Center Street; Walgreens #03196, 5 East Anson Street; Central Iowa Fair with outdoor service, 1308 East Olive Street; City of Marshalltown (Veteran's Memorial Coliseum) with outdoor service, 20 West State Street; JB Bar, 915 Turner Street
3. Approve Retail Tobacco Permit Renewals for FY2026-2027 - Har

Shiva Inc at 613 North 3rd Avenue

4. Appoint Monte Eaton to the Building Board of Appeals, term ending 12/31/30
5. Receipt of April 2026 Building and Trade Permit Report
6. Approve March 2026 Financial Statements
7. Resolution Accepting Bid and Authorizing the Purchase of a 2026 Polaris Ranger Crew XP 1000 for the Price of \$33,424 for Use in the Police Department and Declaring Certain Property Surplus Property and Authorizing Disposal Thereof
8. Resolution to Fix a Date for a Public Hearing on Proposed Ordinance Amendment to Increase a Franchise Fee Under the City's Gas Utility Franchise with Interstate Power & Light Company and to Adopt a Revenue Purpose Statement Related to the Franchise Fee
9. Resolution to Fix a Date for a Public Hearing on Proposed Ordinance Amendment to Increase a Franchise Fee Under the City's Electric Utility Franchise with Interstate Power & Light Company and to Adopt a Revenue Purpose Statement Related to the Franchise Fee
10. Resolution to Fix a Date for a Public Hearing on Ordinance Granting an Electric Utility Franchise to Consumers Energy Cooperative, Establishing a Franchise Fee and Adopting a Revenue Purpose Statement Related to the Franchise Fee
11. Resolution to approve transfers for the 9 month period ending March 31, 2026
12. Resolution Approving Engineer's Certificate of Completion and Accepting Cedar Falls Construction for 2025 PCC Patch Repair Project, #STR23002
13. Resolution Approving Contract Change Order #2 for the 4th Street and Hughes Street Emergency Storm Sewer Repair Project, #SMW25001, an Increase of \$1,046.65
14. Resolution Approving Engineer's Certificate of Completion and Accepting Con-Struct, Inc for 4th St & Hughes St - Emergency Storm Sewer Repair Project, #SMW25001
15. Resolution Approving Contract Change Order #14 for the East Main Street and Center Street Reconstruction Project, #STR22002, an Increase of \$3,454.47
16. Resolution Ordering Construction of the 2026 Street Rehabilitation Project_HMA, #STR26002, Setting Public Hearing on Proposed Plans, Specifications, Form of Contract and Opinion of Probable Cost and

Directing Publication of Notice to Bidders

17. Resolution Approving Contract Change Order #6 for the Water Plaza at Mega-10 Park Project #PRK22004, a Decrease of \$12,826.00
18. Resolution Setting a Public Hearing on the Status of Funding Activities for the Community Development Block Grant - Disaster Recovery Tree Planting Project, #PRK24002

G. REPORTS

1. MPACT Quarterly Update

H. MOTIONS

1. Motion to approve a 5-day Special Class C Retail Alcohol License for Lucky Wife Wine Slushies, for the Marshall County Fair at 1308 East Olive Street, 7/9/26-7/13/26
2. Motion to approve an 8-Month Special Class C Retail Alcohol License with Outdoor Service for Midnight Ballroom LLC DBA Grand Slam Grill at 901 South 6th Street for operation of the Softball Complex Concession Stand

I. RESOLUTIONS

1. Resolution Approving a Professional Services Agreement not to exceed \$72,000 with Snyder & Associates for West End Park Phase II Project, #PRK26001
2. Public Hearing for a Marshalltown Community Development and Housing Needs Assessment, Review of the Application for Community Development Block Grant (CDBG) Derecho Disaster Funds and Authorize ECICOG to Submit the CBDG-DR Application

J. ORDINANCES

1. Ordinance 15119 to Amend the Code of Ordinances, City of Marshalltown, Iowa by Amending Chapter 53: Storm Water by Amending Section 53.006 Rate Structure and Storm Water Rate - Third Reading
2. Temporary Ordinance 15120 of the City of Marshalltown, Iowa, Enacted to Assist City Officials and the RAGBRAI Committee to Address Public Health and Safety Issues Created by the Des Moines Register's Annual Great Bicycle Ride Across Iowa (RAGBRAI) When it Arrives in Marshalltown on July 22, 2026 - First Reading
3. Ordinance 15121 Amending the Code of Ordinances of the City of Marshalltown, Iowa, by Adding a New Chapter 111 Establishing

Requirements for Outdoor Seating Areas on Public Property - First Reading

K. DISCUSSION

1. Center St Viaduct - Railing Option

L. ADJOURNMENT

MISSION STATEMENT

The City of Marshalltown collaborates to provide a welcoming, safe, vibrant, and growing community.

Please visit the City's website for the complete agenda packet and to subscribe to agenda notices and department news at www.marshalltown-ia.gov.

**CITY OF MARSHALLTOWN
COUNCIL PROCEEDINGS
APRIL 27, 2026**

Mayor Ladehoff called the meeting to order at 5:30 pm, April 27, 2026, at the City Hall Council Chambers, 10 W State Street, and led the pledge of allegiance. Roll call-Present: Cahill, Fonseca (via Go-To-Meeting), Mitchell, Nichols (via Go-To-Meeting), Schneider, Thompson, Yopez-Gomez. Public comments for items not on the agenda were provided. Mayor, Council, and Administrator comments were provided. Years of service were recognized for Nick Juel, Police, 5 years; Kevin Pigors, Transit, 15 years; and Patrick Cornwell, Fire, 25 years. Jorge Ramirez of the Marshalltown Futsal League presented Jennifer Hart, Recreation Supervisor, with an award of appreciation for her outstanding service to the league and the community.

CONSENT AGENDA

Motion by Jeff Schneider, second by Mark Mitchell to approve the consent agenda: Approve Minutes 04/13/26 Meeting and Bill List \$1,598,900.96; Approve Alcohol License Ownership Amendment for Dollar General; Receipt of Strategic Goals Report; Resolution Approving Interlocal Grant Agreement for the Iowa/Byrne-Justice Assistance Grant Program (JAG) \$18,631.00 Split 50% with Marshall County, and Approval of Memorandum of Understanding to Share Grant Funds with Marshall County; Resolution Approving Agreement with the Marshall County Arts + Culture Alliance for Public Art Display at 13th Street—"Echo"; Resolution Setting a Public Hearing for a Marshalltown Community Development and Housing Needs Assessment and Review of the Application for Community Development Block Grant (CDBG) Derecho Disaster Funds; Resolution Authorizing Alliant Energy to Make Changes to Marshalltown Street Lighting; Resolution Approving Contract Change Order #13 for the East Main Street and Center Street Reconstruction Project, #STR22002, a Decrease of \$10,250.00; Resolution Approving Contract Change Order #1 for the Center St Viaduct Rehabilitation Project, being Iowa DOT DHM-4797(629)-8K-64 and City Project #STR21002, an Increase of \$160,461.00. Motion carried 7-0.

REPORTS

Zach Maxfield, Manager of the Marshalltown Water Works, outlined the city's water system operations and future plans. The system includes 160 miles of water mains, around 1,000 hydrants and valves, and averages about 20 main breaks per year. Annual hydrant flushing helps identify maintenance needs, with 7-10 hydrants currently out of service. Most water meters have been replaced, improving leak detection and allowing efficient citywide readings. Crews handle many repairs and projects in-house to reduce costs, despite aging infrastructure—some over 100 years old. They are constructing a 6-million-gallon reverse osmosis treatment plant to go with our 12 million gallons a day lime softening treatment plant, expected to be completed by spring 2028, to enhance water capacity. We have high-quality, sourced water from aquifers with no nitrates. Officials emphasized that infrastructure costs are shared evenly across users, with industrial customers providing stable revenue rather than shifting costs to residents. Long-term priorities include replacing lead service lines, maintaining the 50- year-old plant, and developing new well fields to meet future water demand.

MOTIONS

Motion by Gary Thompson, second by Sue Cahill, to approve a new FY26 Retail Tobacco Permit for Har Shiva Inc at 613 North 3rd Avenue. Motion carried 7-0.

RESOLUTIONS

Motion by Jeff Schneider, second by Sue Cahill, to approve Resolution Authorizing the Submittal of a Grant Application for Airport Sanitary Sewer System Improvement and Certifies Local Match is Available. Heather Thomas, Public Works Director, advised that the project includes improving both the conveyance sewers and on-site wastewater treatment at an estimated cost of \$368,600, with 75% being the grant request and 25% being the local share. Public comment was provided. Motion carried 6-1, Marco Yopez- Gomez dissenting.

Mayor Ladehoff opened the public hearing at 6:15 pm for the vacation of a portion of alleyway between South 12th Street and 13th Street adjacent to the Miller Middle School Practice Fields. Clayton Ender, Assistant Housing and Community Development Director, advised that this was a request from the Marshalltown Community School District to vacate and transfer by gift, 0.02 acres of an alley located between South 12th Street and South 13th Street, adjacent to the Miller Middle School practice fields. No written or public comments were received. The public hearing was closed at 6:16 pm. Motion by Jeff Schneider, second by Mark Mitchell, to approve the Resolution Providing for the Vacation of a Portion of an Alleyway Located Between S 12th Street and S 13th Street Adjacent to the Miller Middle School Practice Fields and Approving the Quit Claim Deed to the Marshalltown Community School District. Motion carried 7-0.

Mayor Ladehoff opened the public hearing at 6:17 pm on a proposal to enter into an essential purpose loan agreement. Carol Webb, City Administrator, advised that the public hearing is part of the legal process required to repurpose previously issued bond proceeds for authorized capital purposes. The City intends to use \$26,000 in unspent proceeds from prior bond issues for sidewalk improvements. No written or public comments were received. The public hearing was closed at 6:21 pm.

Mayor Ladehoff opened the public hearing at 6:22 pm for a proposal to enter into a trail improvements loan agreement. Carol Webb, City Administrator, advised that the public hearing is part of the legal process required to repurpose previously issued bond proceeds for authorized capital purposes. The City intends to use \$250,000 in unspent proceeds from prior bond issues for trail improvements. This reallocation from council-designated local option sales tax was made by council direction during budget discussions for bridges 2-5 on the Iowa Rivers Edge Trail. No written public comment was received. Public comment was provided. The public hearing was closed at 6:31 pm.

Mayor Ladehoff opened the public hearing at 6:31 pm for a proposal to enter into a Police/Fire Facilities Loan Agreement. Carol Webb, City Administrator, advised that the public hearing is part of the legal process required to repurpose previously issued bond proceeds for authorized capital purposes. The City intends to use \$95,000 in unspent proceeds from prior bond issues for Police/Fire Facility and associated grounds improvements. No written comments were received. Public comments were provided. The public hearing was closed at 6:32 pm.

Carol Webb, City Administrator, advised that this action authorizes the reallocation of bond proceeds instead of issuing new debt for sidewalk improvements not to exceed \$26,000; recreation trail and trail bridge improvements not to exceed \$250,000; and Police/Fire Department facility and associated grounds improvements not to exceed \$95,000. Motion by Jeff Schneider, second by Sue Cahill, to approve Resolution Taking Additional Action on Proposal to Enter into General Obligation Loan Agreements, Combining Loan Agreements, and Repurposing Bond Proceeds. Motion carried 6-1, Gary Thompson dissenting.

Mayor Ladehoff opened the public hearing at 6:34 pm for adopting the budget and certifying taxes for the fiscal year ending June 30, 2027, and related transfers between funds. Diana Steiner, Finance Director, advised that the property tax levy is set at \$16.25 per \$1,000 of taxable valuations. This is an increase of \$.25 for the transit system, which will generate \$268,000 in additional funding for bus replacement. After staff and council made designated budget cuts, there was a deficit of \$1,033,223, which will be covered by council-designated local option sales tax. No written or public comments were received. The public hearing was closed at 6:36 pm. Motion by Jeff Schneider, second by Marco Yopez-Gomez, to approve the Resolution Adopting the Budget and Certifying Taxes for the Fiscal Year Ending June 30, 2027, and Related Transfers Between Funds. Motion carried 7-0.

Mayor Ladehoff opened the public hearing at 6:37 pm for adopting the budget amendment for the fiscal year ending June 30, 2026, and the transfers between funds. Diana Steiner, Finance Director, advised that the budget amendment does not increase property taxes. No written or public comments were received. The public hearing was closed at 6:37 pm. Motion by Jeff Schneider, second by Gary Thompson, to approve the Resolution Adopting the Budget Amendment for the Fiscal Year Ending June 30, 2026, and the Transfers Between Funds. Motion carried 7-0.

Mayor Ladehoff opened the public hearing at 6:38 pm for approving the FY2026-FY2030 Capital Improvement Plan. Diana Steiner, Finance Director, advised that a 5-year capital improvement plan is required by the State of Iowa. The plan funds major equipment, vehicles, and construction projects. No written comments were received. Public comment was provided. The public hearing was closed at 6:41 pm. Motion by Mark Mitchell, second by Jeff Schneider, to approve the Resolution Approving the FY2026-FY2030 Capital Improvement Plan. Motion carried 7-0.

ORDINANCES

Motion by Sue Cahill, second by Mark Mitchell, to adopt the third reading of Ordinance 15115 to Amend the Code of Ordinances, City of Marshalltown, Iowa, Chapter 76: Traffic Schedules, Schedule IV. Stop Intersections & Schedule V. Yield Intersections. Motion carried 7-0.

Motion by Gary Thompson, second by Mark Mitchell, to adopt the third reading of Ordinance 15116 to Amend the Code of Ordinances, Chapter 156 Zoning, Regarding Accessory Structure Locations and Zoning Definitions. Motion carried 6-1, Marco Yopez-Gomez dissenting.

Motion by Gary Thompson, second by Sue Cahill, to adopt the third reading of Ordinance 15117 to Amend the City of Marshalltown Municipal Code by Adopting the 2021 International

Residential Code, Including Appendix AF (Radon Control methods). Motion carried 7-0.

Motion by Gary Thompson, second by Jeff Schneider, to adopt the third reading of Ordinance 15118 to Amend the Code of Ordinances, City of Marshalltown, Iowa, Chapter 93 Parks and Recreation; Leisure, Section 93.001: Camping; Time Limits; Permit; Fee. Motion carried 7-0.

Motion by Gary Thompson, second by Jeff Schneider, to adopt the second reading of Ordinance 15119 to Amend the Code of Ordinances, City of Marshalltown, Iowa by Amending Chapter 53: Storm Water by Amending Section 53.006 Rate Structure and Storm Water Rate. Motion carried 7-0.

DISCUSSION

Carol Webb, City Administrator, presented a discussion on whether the city should move toward a consolidated garbage collection system and whether to require mandatory garbage service or allow self-hauling. Currently, the city operates under an open market system, where residents choose among licensed haulers. This results in multiple haulers serving the same neighborhoods on different days. A consultant previously determined that a consolidated system is not feasible under the current open market structure and would require a competitive bidding process. The majority of the council does not support a consolidated system. Staff will propose a city code amendment to explicitly allow residents to either contract with a hauler or self-haul. Public comment was provided.

Tom Deimerly, 210 East Main Street, provided additional information about his request for sidewalk repair and raised concerns about the impact of a proposed alley conversion. Noting that the building relies on a central delivery area accessed by double doors serving four suites, and that changes could disrupt the delivery of large items. He also noted issues with proposed bollards and the lack of access. He stated he should not bear the cost of sidewalk repair. He proposed incorporating the adjacent green space into the Main Street project if the city repairs the sidewalk in the current project phase. He also expressed concern about liability if the sidewalk remains unrepaired for the estimated 10 years until Phase 8 of the plan is completed with the sidewalk replacement, and asked for written assurance that he wouldn't be held responsible in the meantime. Cahill supported fixing the sidewalk but said the current proposal goes beyond what was previously discussed, especially regarding the alley. She suggested addressing immediate, manageable issues first and revisiting larger ideas like green space and art later. Schneider noted the sidewalk is scheduled for replacement in a future phase and highlighted the potential community benefit of features like the archway. Mitchell cautioned that initiating sidewalk work could create broader obligations, pointing out that the property was purchased in its current condition. Motion by Melisa Fonseca, second by Jeff Schneider, to proceed with the pedestrian alleyway and leave the sidewalk replacement in phase 8 of the Main Street Reconstruction project. Motion carried 4-3, Sue Cahill, Greg Nichols, and Gary Thompson dissenting.

ADJOURNMENT

The meeting adjourned at 7:47 pm.

Respectfully Submitted,

CITY OF MARSHALLTOWN, IOWA

Alicia Hunter

Alicia Hunter, City Clerk

Mike Ladehoff, Mayor

ATTEST:

Alicia Hunter, City Clerk

BILL LIST 05/11/26

Advertising

Trending.Media/2 163.00

Consulting & Professional Fees

AHLERS.COONEY/1 864.00
 Bernie.Lowe/1 4,191.02
 Calhoun-Burns/1 13,707.75
 Foth Infrastruc/1 9,524.60
 Howard.R.Green/4 43,486.25
 Iowa.One.Call/2 498.90
 McClure.Engrg/1 10,207.75
 RDG.Planning/3 57,180.75
 Region 6/1 205.00

Contracts

AAA.Septic/2 445.00
 Advance.Garage./2 1,100.00
 ARL/1 7,499.08
 BDH/28 9,865.34
 Boulder.Contract/1 213,709.70
 Cedar Falls Con/1 2,910.00
 City.Laundrying/1 168.59
 Cntrl.IA.Farm/1 776.98
 Construct/1 17,454.81
 CTI Ready Mix/2 657.50
 Dans Overhead D/1 3,104.00
 Garling.Constr/1 158,423.72
 Hometown Vet/3 1,262.98
 Kapaun.Brown/1 962.71
 Macqueen.Equip/5 46,357.38
 Marco.Holdings/2 1,377.50
 Marsh.Co.Landfi/1 40.00
 Mid-Iowa Enterp/1 38,241.92
 Midwest Office/1 149.95
 Musco Sports Li/1 13,500.00
 Park,K/1 1,315.75
 PerkinElmer US/2 12,106.80
 Prairie Waste/11 1,215.02
 Premier.Equip/1 74.64
 Safe Building/2 13,780.00
 Schendel.Pest.C/4 121.42
 Steckelberg Vet/1 323.45
 Stericycle.Inc/1 75.92
 Sterling.Fire/3 656.00
 TOP.NOTCH.TREE./1 16,800.00
 Tri.State.Lock/1 114.00
 Tyler.Technolog/1 6,160.75
 Wendler Inc/1 25,098.75
 Xerox Corp/1 25.72
 Ziegler/3 1,225.68

Medical

Bernie.Lowe/1 31,986.50
 Covenant Workpl/1 432.25
 HARTFORD.ACCTS/2 7,618.77

Payroll.Net

Payroll/1 386,600.42

Refund/Reimbursed

Burkle, Teresa/1 75.00
 Wise, Elizabeth/1 35.12

Rents/Leases

201 E Main MT/14 5,305.00
 6 Pack Propert/1 371.00
 A.White/1 726.00
 Ackley.Housing/5 1,114.00
 Adey LLC/1 665.00
 Arrowhead Homes/1 321.00
 BJ&J.LLC/1 277.00
 BLOOD,A/1 412.00
 Blue Fund I/1 311.00
 Borota,K/1 412.00
 Brinkmeyer, Rob/1 305.00
 Brodin,C/1 57.00
 Brown, Larry/1 332.00
 Brummel, Michae/1 105.00
 BTG Rental LLC/1 230.00
 Buckaroo.LLC/2 931.00
 CIRSI/7 522.00
 Clock Tower Sen/9 3,190.00
 CMHC.INVEST/1 192.00
 Columbus Metro/1 3,379.00
 Conzalez, Renat/1 621.00
 Crestview Apts/22 8,601.00
 D.D.Rentals/5 1,690.00
 Daters, Toni Ra/1 401.00
 Douglas Ter Apt/3 1,688.00
 Ealy, Carol/1 523.00
 EPC LLC/2 708.00
 Etter, Connie/1 650.00
 Eubanks,C/1 338.00
 Flores, Antonio/1 285.00
 Friendly.Valley/3 326.00
 Glenda.Drive.LL/3 1,115.00
 Gorrell, Joseph/1 650.00
 Gray,D/2 1,121.00
 Hala,J/5 1,379.00
 Hatch,R/2 1,383.00
 HAVELKA,B/1 696.00
 HESSENIUS,R/1 615.00
 Hilltop.Village/2 470.00
 Ho Phi Nguyen/1 550.00
 House Harvester/1 299.00
 HOWARD,J/1 164.00
 Inman, Jeffrey/1 142.00
 JBI.COOP.Assn/5 2,037.00
 JDL.Rental.Coop/1 490.00
 Jimenez, Luis/1 358.00
 Kading Prop LLC/4 2,862.00
 Kramer, Marcia/1 388.00
 Lawthers.Prop.M/1 156.00
 Linton, Tyler/2 643.00
 LUENSE,B/6 2,777.00
 Lusoma LLC/2 626.00

BILL LIST 05/11/26

MD Kruse Enter/1	90.00	Menards/9	131.95
MOJO Rentals/1	311.00	One Source Aqu/2	60.00
Moore, Michelle/1	295.00	Patton,Camille/1	46.00
Mtown Lofts LLC/15	5,290.00	Petermeier,J/1	40.00
Mtown/Westown/20	6,187.00	Pro Hydro/1	4,620.00
Ndihokubwayo,L/1	299.00	Ranson, Robert/1	40.00
North.Tama.Hsg/1	51.00	Reiong, Elizabe/1	77.00
Oetker,D/3	478.00	Scharnweber.Wtr/1	27.00
Park.Elms,LLC/4	1,365.00	Scrap and More/1	190.00
PHR Properties/1	320.00	Squires,Chris/1	86.00
Plymat Jr, Will/1	546.00	Stiegelmeier, C/1	10.00
Premier/4	1,651.00	Titus,K/1	64.00
PremierIowaCity/5	1,600.00	T-Mobile/37	1,900.67
Pyramid Propert/3	751.00	TOP.NOTCH.TREE./1	950.00
RA.Rental.Prop/2	1,035.00	Wallace, Yianna/1	41.00
Redborg,Kirsten/1	376.00	Weatherly,Cass/1	31.00
Reed,T/1	422.00	Wirth, Tammy/1	28.00
Rice, Quinton/1	403.00	WW.Grainger/4	568.12
River.Birch/1	298.00		
River.Oaks/4	1,691.00	Supplies/Parts	
RMB Cooperative/2	1,501.00	AplConceptsInc/1	4,987.50
Rural Revival/1	320.00	Arnold.Motor/15	1,233.51
Schmidt,M/2	1,072.00	Atticus Enter/1	7,740.00
Superior.Rental/6	1,514.00	BDH/1	30.00
Sweet Pea/2	846.00	Bitumnous/7	5,143.33
Swiff, Scott/1	430.00	Bounce Imaging/1	4,995.00
Tallcorn.Tower/12	3,776.00	Carrico.Aq.Rs/1	477.10
TAYLOR,M/1	350.00	Cessford/3	1,209.36
TOWN.APARTMENT/2	692.00	City.Laundrying/2	125.92
TTLIC.Hsg/3	1,709.00	Cntrl.IA.Farm/1	467.65
Walker, Angela/1	308.00	CTI Ready Mix/4	1,716.00
Worsfold Farm/1	370.00	Cummins.Service/2	367.83
		Eurofins Enviro/1	256.40
Service/Repairs		Fastenal Co/2	37.29
Advance.Garage./1	195.00	Galls.LLC/5	446.73
Airgas USA Inc/1	95.10	Gillig.LLC/2	2,347.62
Arnold.Motor/1	16.12	Grimes.Asphalt/1	1,088.10
Betsinger,L/1	75.00	Hannam.Autom/1	800.00
Bly,Josh/3	2,955.00	Homes.Radiator/1	155.00
Cline, Troy/7	4,905.00	IA.Prison.Ind/1	120.00
Columbus Metro/1	99.44	Kiesler Police/1	1,439.58
Daves.Crane/1	1,020.00	Kwik.Trip/1	177.07
Electric.Supply/2	1,169.06	Macqueen.Equip/3	5,878.05
Gentry,S/2	68,075.00	Marsh.Co.Engr/22	21,836.40
Greazel, Lance/1	40.00	Martin.Marietta/3	1,518.75
Heart.of.Iowa/15	3,903.11	Menards/7	370.07
Homes.Radiator/1	449.00	Microbac Lab/1	331.00
Hotsy.Cleaning/1	512.70	Midland.Scienti/1	37.11
I.C.A.P./1	2,019.00	Miracle.Recreat/1	3,181.38
IA DIAL/2	190.00	Mobotrex.Inc./1	21,179.00
IMON/1	134.99	Nebraska Air/1	1,669.46
Language Line/1	58.50	Nutrien.Ag.Sol/1	243.80
Legg,R/1	40.00	Office.Express/2	60.43
Louis, Marie/1	7.00	Plumb.Supply/1	161.67
Macqueen.Equip/1	5,544.28	Racom.Corp/3	6,535.45
Mattingly, Ruth/1	40.00	ShoBiz,Minutema/1	22.46

BILL LIST 05/11/26

Sign.Creations/1	195.00
SMI.Co/1	2,085.00
Strands/1	126.55
Thiesens.Supply/13	1,341.09
Tri.State.Lock/1	90.00
Trojan Tech/1	6,418.44
Vajgrt.R/1	183.18
Travel/Training	
Critchlow,Cory/1	178.50
Schmelzer, Hunt/1	178.50
Wonderlin, Stev/1	178.50
Utilities	
Alliant.Energy/56	36,291.35
I.R.U.A./1	204.56
Mtwn.Wtrwrks/12	465.99
WoodRiver.Enrgy/5	7,475.31
Wage Assignment	
American.Educa./1	64.41
Collection.Svs./5	1,041.29
Colonial.Life/1	271.49
Fidelity Securi/2	503.83
Giannetto, Anto/1	25.00
I.R.S./6	101,560.87
IA.Treasurer/2	15,047.86
Mission Square/12	16,867.05
St Francis/1	5.00
Streichers Inc/1	10.00
TotalAdmin.Serv/4	9,148.04
Total/706	1,652,931.01

BILL LIST 05/11/26

Account Number	Vendor Name	Description (Item)	Amount
184.5030.5242.000	201 E Main MT LLC	Rent Assistance	\$ 315.00
184.5030.5242.000	201 E Main MT LLC	Rent Assistance	\$ 447.00
184.5030.5242.000	201 E Main MT LLC	Rent Assistance	\$ 449.00
184.5030.5242.000	201 E Main MT LLC	Rent Assistance	\$ 436.00
184.5030.5242.000	201 E Main MT LLC	Rent Assistance	\$ 455.00
184.5030.5242.000	201 E Main MT LLC	Rent Assistance	\$ 475.00
184.5030.5242.000	201 E Main MT LLC	Rent Assistance	\$ 435.00
184.5030.5242.000	201 E Main MT LLC	Rent Assistance	\$ 416.00
184.5030.5242.000	201 E Main MT LLC	Rent Assistance	\$ 321.00
184.5030.5242.000	201 E Main MT LLC	Rent Assistance	\$ 445.00
184.5030.5242.000	201 E Main MT LLC	Rent Assistance	\$ 273.00
184.5030.5242.000	201 E Main MT LLC	Rent Assistance	\$ 237.00
184.5030.5242.000	201 E Main MT LLC	Rent Assistance	\$ 158.00
184.5030.5242.000	201 E Main MT LLC	Rent Assistance	\$ 443.00
184.5030.5242.000	6 Pack Properties LLC	Rent Assistance	\$ 371.00
001.4030.5342.000	AAA Septic Service Inc	Mega 10 Park rentals	\$ 270.00
001.4030.5342.000	AAA Septic Service Inc	West End Park rental	\$ 175.00
184.5030.5242.000	Ackley Housing Inc	Rent Assistance	\$ 314.00
184.5030.5242.000	Ackley Housing Inc	Rent Assistance	\$ 249.00
184.5030.5242.000	Ackley Housing Inc	Rent Assistance	\$ 146.00
184.5030.5242.000	Ackley Housing Inc	Rent Assistance	\$ 189.00
184.5030.5242.000	Ackley Housing Inc	Rent Assistance	\$ 216.00
184.5030.5242.000	Adey LLC	Rent Assistance	\$ 665.00
001.1050.5410.000	Advance Garage Doors Inc	Fire dept door 6 services	\$ 195.00
001.4030.5342.000	Advance Garage Doors Inc	PWB garage door #1 spare springs	\$ 440.00
110.2010.5342.000	Advance Garage Doors Inc	PWB garage door #1 spare springs	\$ 660.00
001.6040.5236.000	Ahlers & Cooney	Labor relations	\$ 864.00
110.2010.5380.000	Airgas USA Inc	Street dept rentals	\$ 95.10
001.1030.5481.000	Alliant Energy	25 N Center St Civil Defense Sirens	\$ 100.00
001.1030.5481.000	Alliant Energy	7 W State St tornado siren	\$ 54.66
001.1099.5481.000	Alliant Energy	909 S 2nd St Fire & Police Bldg	\$ 6,720.32
001.1099.5482.000	Alliant Energy	909 S 2nd St Fire & Police Bldg	\$ 257.45
001.2020.5481.000	Alliant Energy	NE corner S 1st Ave / Church St parking lot	\$ 138.27
001.2080.5481.000	Alliant Energy	2651 170th St Runway lights	\$ 149.57
001.2080.5481.000	Alliant Energy	2651 170th St TEMP	\$ 514.10
001.4030.5481.000	Alliant Energy	311 E Anson St Park	\$ 22.69
001.4030.5481.000	Alliant Energy	802 S 3rd St Skate Park	\$ 137.50
001.4030.5481.000	Alliant Energy	915 S 4th Ave Anson Park	\$ 24.92
001.4030.5481.000	Alliant Energy	108 N 2nd Ave Alley - Farmers Market	\$ 31.96
001.4030.5481.000	Alliant Energy	Highland Acres Rd	\$ 32.44
001.4030.5481.000	Alliant Energy	Broadmore Assistance League	\$ 14.18
001.4030.5481.000	Alliant Energy	220 N 13th St Rest room	\$ 40.95
001.4030.5481.000	Alliant Energy	N 13th St	\$ 124.44
001.4030.5481.000	Alliant Energy	Arnolds Park	\$ 13.02
001.4030.5481.000	Alliant Energy	516 N 3rd St Elks Park	\$ 26.01
001.4030.5481.000	Alliant Energy	500 Plaza Hts Rd	\$ 46.10
001.4030.5481.000	Alliant Energy	S 3rd Ave Kiwanis Park	\$ 35.93
001.4045.5481.000	Alliant Energy	212 Washington St Aquatic Center	\$ 258.54
001.4065.5481.000	Alliant Energy	10 W State St COLISEUM	\$ 4,053.90
001.4065.5482.000	Alliant Energy	10 W State St COLISEUM	\$ 274.35
001.6050.5481.000	Alliant Energy	24 N Center St Municipal Bldg	\$ 665.07
001.6051.5481.000	Alliant Energy	36 N Center St- Carnegie Bldg	\$ 1,143.72
001.6051.5482.000	Alliant Energy	36 N Center St- Carnegie Bldg	\$ 186.17
110.2030.5481.000	Alliant Energy	17 N Center St metered	\$ 99.83
110.2030.5481.000	Alliant Energy	3098 Lincoln Way sign	\$ 25.15
110.2030.5481.000	Alliant Energy	6 S 2nd St Alley	\$ 45.42
110.2030.5481.000	Alliant Energy	36 W Main St alley	\$ 37.49
110.2030.5481.000	Alliant Energy	207 W Main St	\$ 49.02
110.2030.5481.000	Alliant Energy	106 S Center St metered	\$ 37.44
110.2030.5481.000	Alliant Energy	220 E Main St alley	\$ 49.09
110.2030.5481.000	Alliant Energy	404 1/2 S Center St Viaduct	\$ 86.10
110.2030.5481.000	Alliant Energy	36 E Main St Alley	\$ 24.20
110.2030.5481.000	Alliant Energy	120 E Main St Alley	\$ 42.71

110.2030.5481.000	Alliant Energy	Market St Bridge lights	\$ 79.08
110.2030.5481.000	Alliant Energy	MARSHALLTOWN	\$ 18,702.37
110.2030.5481.000	Alliant Energy	N 13th Street lights	\$ 110.63
110.2030.5481.000	Alliant Energy	25 N 13th St	\$ 57.68
110.2030.5481.000	Alliant Energy	1707 Laurel Dr Viaduct Light	\$ 32.75
110.2040.5481.000	Alliant Energy	E Anson St & 3rd Ave	\$ 56.84
110.2040.5481.000	Alliant Energy	S Center St & Boone St	\$ 43.99
110.2040.5481.000	Alliant Energy	S Center St & Linn St	\$ 39.83
110.2040.5481.000	Alliant Energy	S 3rd Ave & Linn St	\$ 113.23
110.2040.5481.000	Alliant Energy	N Center St & Church St	\$ 40.79
110.2040.5481.000	Alliant Energy	Westwood Dr & Center St	\$ 34.50
110.2040.5481.000	Alliant Energy	W Meadowlane & Center St	\$ 43.82
110.2040.5481.000	Alliant Energy	S Center St & South St	\$ 44.14
110.2040.5481.000	Alliant Energy	S Center St & Anson	\$ 64.65
110.2040.5481.000	Alliant Energy	W High St & S 6th St	\$ 27.96
110.2040.5481.000	Alliant Energy	S 1st Ave & E Anson St	\$ 55.56
110.2040.5481.000	Alliant Energy	S Center St & Olive St	\$ 51.97
110.2040.5481.000	Alliant Energy	S 6th St & Olive St	\$ 36.10
142.4030.5481.000	Alliant Energy	800 S 6th St Softball Diamonds	\$ 258.54
610.8016.5481.000	Alliant Energy	S 2nd St & Player St	\$ 633.82
610.8016.5481.000	Alliant Energy	N 22nd St	\$ 200.39
999.1121.000	American Education Services	Wage Withholding	\$ 64.41
001.1090.5331.000	Animal Rescue League	Annual contract taking care of animal City Limits	\$ 7,499.08
152.1010.5718.000	Applied Concepts Inc	Speed radars	\$ 4,987.50
001.1010.5565.000	Arnold Motor Supply	PD RAV4 oil filter	\$ 8.86
001.1010.5565.000	Arnold Motor Supply	PD 522 brake rotor	\$ 102.47
001.1010.5565.000	Arnold Motor Supply	PD engine oil filters	\$ 78.61
001.1010.5565.000	Arnold Motor Supply	PD Edge brakes and rotors	\$ 177.33
001.4010.5410.000	Arnold Motor Supply	Library exhaust fan belt	\$ 16.12
001.4030.5565.000	Arnold Motor Supply	Parks 718 battery	\$ 233.65
110.2010.5489.000	Arnold Motor Supply	Triangle reflector warning	\$ 32.47
110.2010.5565.000	Arnold Motor Supply	battery core deposit	\$ (48.00)
110.2010.5565.000	Arnold Motor Supply	Street oil filter	\$ 6.05
110.2010.5565.000	Arnold Motor Supply	Street dept 58 filters	\$ 83.42
110.2010.5600.000	Arnold Motor Supply	disposable latex gloves	\$ (34.99)
110.2010.5600.000	Arnold Motor Supply	Skat Blast extra large cabinet inner lens protecto	\$ 61.32
110.2010.5600.000	Arnold Motor Supply	Street shop supplies	\$ 228.58
110.2010.5600.000	Arnold Motor Supply	WD-40 and disposable gloves	\$ 234.46
110.2010.5600.000	Arnold Motor Supply	Street shop grease	\$ 32.05
110.2010.5718.000	Arnold Motor Supply	Street shop grease gun	\$ 37.23
184.5030.5242.000	Arrowhead Homes LLC	Rent Assistance	\$ 321.00
341.5010.5609.000	Atticus Enterprises LLC	Parks 51 trees	\$ 7,740.00
001.1010.5347.000	BDH INFORMATION TECHNOLOGY LLC	PD Covert Internet service	\$ 79.34
001.1010.5347.000	BDH INFORMATION TECHNOLOGY LLC	Block time - 20hrs Police dept	\$ 1,266.25
001.1010.5347.000	BDH INFORMATION TECHNOLOGY LLC	PD 4500 Veeam Backup & Recovery	\$ 57.00
001.4010.5347.000	BDH INFORMATION TECHNOLOGY LLC	Block time 10hrs Library	\$ 633.13
001.4065.5600.000	BDH INFORMATION TECHNOLOGY LLC	Aquatic Center projector remote	\$ 30.00
001.6070.5347.000	BDH INFORMATION TECHNOLOGY LLC	SIEM infrastructure device monitoring service	\$ 650.00
001.6070.5347.000	BDH INFORMATION TECHNOLOGY LLC	Housing remote monitoring & management	\$ 65.00
001.6070.5347.000	BDH INFORMATION TECHNOLOGY LLC	Block time 50hrs General Fund	\$ 3,165.62
001.6070.5347.000	BDH INFORMATION TECHNOLOGY LLC	Fire dept remote monitoring & management	\$ 160.00
001.6070.5347.000	BDH INFORMATION TECHNOLOGY LLC	Library remote monitoring & management	\$ 135.00
001.6070.5347.000	BDH INFORMATION TECHNOLOGY LLC	Coliseum remote monitoring & management	\$ 40.00
001.6070.5347.000	BDH INFORMATION TECHNOLOGY LLC	Finance remote monitoring & management	\$ 25.00
001.6070.5347.000	BDH INFORMATION TECHNOLOGY LLC	Parks remote monitoring & management	\$ 30.00
001.6070.5347.000	BDH INFORMATION TECHNOLOGY LLC	Aquatic Ctr remote monitoring & management	\$ 20.00
001.6070.5347.000	BDH INFORMATION TECHNOLOGY LLC	Admin remote monitoring & management	\$ 20.00
001.6070.5347.000	BDH INFORMATION TECHNOLOGY LLC	City Hall remote monitoring & management	\$ 125.00
001.6070.5347.000	BDH INFORMATION TECHNOLOGY LLC	Police remote monitoring & management	\$ 355.00
001.6070.5347.000	BDH INFORMATION TECHNOLOGY LLC	City council remote monitoring & management	\$ 40.00
001.6070.5347.000	BDH INFORMATION TECHNOLOGY LLC	Veeam Monthly subsc Tyler users	\$ 209.00
001.6070.5347.000	BDH INFORMATION TECHNOLOGY LLC	Sentinel One Singularity complete advanced EDR	\$ 152.00
001.6070.5347.000	BDH INFORMATION TECHNOLOGY LLC	Standalone Advanced SPAM/ virus emailing	\$ 175.00
001.6070.5347.000	BDH INFORMATION TECHNOLOGY LLC	SIEM server device monitoring service	\$ 200.00
110.2010.5347.000	BDH INFORMATION TECHNOLOGY LLC	Public Works remote monitoring & management	\$ 55.00
110.2010.5347.000	BDH INFORMATION TECHNOLOGY LLC	PW 4500 Veeam Backup & Recovery	\$ 19.00

110.2060.5347.000	BDH INFORMATION TECHNOLOGY LLC	Engineering remote monitoring & management	\$ 75.00
110.2060.5347.000	BDH INFORMATION TECHNOLOGY LLC	PW 4500 Veeam Backup & Recovery	\$ 38.00
610.8015.5347.000	BDH INFORMATION TECHNOLOGY LLC	WPCP remote monitoring & management	\$ 75.00
610.8015.5347.000	BDH INFORMATION TECHNOLOGY LLC	WPC Firewall	\$ 1,981.00
690.8050.5347.000	BDH INFORMATION TECHNOLOGY LLC	Transit remote monitoring & management	\$ 20.00
881.1050.5230.000	BERNIE LOWE & ASSOC Inc	Paid medical claims	\$ 4,191.02
881.1050.5339.000	BERNIE LOWE & ASSOC Inc	Paid medical claims	\$ 31,986.50
001.4010.5343.000	Betsinger McCann, Linda	Speaking at Library	\$ 75.00
110.2010.5617.000	Bitumnous Materials & Supply	emulsified asphalt	\$ 1,078.77
110.2010.5617.000	Bitumnous Materials & Supply	emulsified asphalt	\$ 530.22
110.2010.5617.000	Bitumnous Materials & Supply	emulsified asphalt	\$ 530.22
110.2010.5617.000	Bitumnous Materials & Supply	emulsified asphalt	\$ 542.41
110.2010.5617.000	Bitumnous Materials & Supply	emulsified asphalt	\$ 1,011.69
110.2010.5617.000	Bitumnous Materials & Supply	emulsified asphalt	\$ 542.41
110.2010.5617.000	Bitumnous Materials & Supply	emulsified asphalt	\$ 907.61
184.5030.5242.000	BJ&J LLC	Rent Assistance	\$ 277.00
184.5030.5242.000	Blood, Alex	Rent Assistance	\$ 412.00
184.5030.5242.000	Blue Fund I	Rent Assistance	\$ 311.00
001.4030.5386.000	Bly, Josh	October mowings	\$ 2,595.00
110.2010.5386.000	Bly, Josh	April Mowings	\$ 135.00
740.8067.5386.000	Bly, Josh	October mowings	\$ 225.00
184.5030.5242.000	Borota, Kent	Rent Assistance	\$ 412.00
363.2010.5342.000	BOULDER CONTRACTING LLC	Center St Viaduct Const 3/26/26-4/30/26	\$ 213,709.70
030.1010.5600.000	Bounce Imaging Inc	Imaging Explorer Tactical Audio Throw & Pole	\$ 4,995.00
184.5030.5242.000	Brinkmeyer, Robert	Rent Assistance	\$ 305.00
184.5030.5242.000	Brodin, Chris	Rent Assistance	\$ 57.00
184.5030.5242.000	Brown, Larry	Rent Assistance	\$ 332.00
184.5030.5242.000	Brummel, Michael	Rent Assistance	\$ 105.00
184.5030.5242.000	BTG Rental LLC	Rent Assistance	\$ 230.00
184.5030.5242.000	Buckaroo LLC	Rent Assistance	\$ 477.00
184.5030.5242.000	Buckaroo LLC	Rent Assistance	\$ 454.00
110.2050.5980.000	Burkle, Teresa	snowplow mailbox damage	\$ 75.00
340.4030.5233.000	CALHOUN-BURNS AND ASSOCIATES, INC	Construction Phase Engr - IRET B2-B5	\$ 13,707.75
139.4045.5607.000	Carrico Aquatic Resources Inc	Aquatic Center pool supplies	\$ 477.10
363.2012.5342.000	Cedar Falls Construction Inc	2025 PCC Patch Repair Projec - Cons 11/1/25-4/1/26	\$ 2,910.00
001.2080.5565.000	Central Iowa Farm Store Inc	Mower Repair and New Blades - Airport Kubota	\$ 467.65
140.4030.5750.000	Central Iowa Farm Store Inc	14 plaque plates for Park & Rec	\$ 776.98
184.5030.5242.000	CENTRAL IOWA RESIDENTIAL SERV INC	Rent Assistance	\$ 110.00
184.5030.5242.000	CENTRAL IOWA RESIDENTIAL SERV INC	Rent Assistance	\$ 102.00
184.5030.5242.000	CENTRAL IOWA RESIDENTIAL SERV INC	Rent Assistance	\$ 14.00
184.5030.5242.000	CENTRAL IOWA RESIDENTIAL SERV INC	Rent Assistance	\$ 90.00
184.5030.5242.000	CENTRAL IOWA RESIDENTIAL SERV INC	Rent Assistance	\$ 72.00
184.5030.5242.000	CENTRAL IOWA RESIDENTIAL SERV INC	Rent Assistance	\$ 70.00
184.5030.5242.000	CENTRAL IOWA RESIDENTIAL SERV INC	Rent Assistance	\$ 64.00
110.2010.5620.000	Cessford	Street dept crushed rock	\$ 410.70
110.2010.5620.000	Cessford	Street dept crushed rock	\$ 698.27
110.2010.5620.000	Cessford	Street dept crushed rock	\$ 100.39
110.2010.5342.000	CITY LAUNDERING COMPANY	cleaning and insurance	\$ 168.59
110.2010.5600.000	CITY LAUNDERING COMPANY	supplies	\$ 85.92
690.8050.5132.000	CITY LAUNDERING COMPANY	Transit dept - uniform cleaning	\$ 40.00
001.1075.5261.000	Cline, Troy	Nuisance clean up	\$ 1,015.00
001.1075.5261.000	Cline, Troy	Nuisance clean ups	\$ 335.00
001.1075.5261.000	Cline, Troy	Nuisance clean up	\$ 490.00
001.1075.5261.000	Cline, Troy	Nuisance clean ups	\$ 2,035.00
001.1075.5263.000	Cline, Troy	City owned mowings	\$ 450.00
001.1075.5263.000	Cline, Troy	Nuisance mowing	\$ 250.00
001.1075.5263.000	Cline, Troy	Nuisance mowings	\$ 330.00
184.5030.5242.000	Clock Tower Senior LP	Rent Assistance	\$ 333.00
184.5030.5242.000	Clock Tower Senior LP	Rent Assistance	\$ 175.00
184.5030.5242.000	Clock Tower Senior LP	Rent Assistance	\$ 220.00
184.5030.5242.000	Clock Tower Senior LP	Rent Assistance	\$ 329.00
184.5030.5242.000	Clock Tower Senior LP	Rent Assistance	\$ 685.00
184.5030.5242.000	Clock Tower Senior LP	Rent Assistance	\$ 466.00
184.5030.5242.000	Clock Tower Senior LP	Rent Assistance	\$ 244.00
184.5030.5242.000	Clock Tower Senior LP	Rent Assistance	\$ 346.00
184.5030.5242.000	Clock Tower Senior LP	Rent Assistance	\$ 392.00

184.5030.5242.000	CMHC Investments LLC	Rent Assistance	\$ 192.00
999.1121.000	Collection Services Center	Child Support	\$ 139.77
999.1121.000	Collection Services Center	Child Support	\$ 423.86
999.1121.000	Collection Services Center	Child Support	\$ 60.24
999.1121.000	Collection Services Center	Child Support	\$ 23.00
999.1121.000	Collection Services Center	Child Support	\$ 394.42
999.1133.000	Colonial Life	COLONIAL LIFE INSURANCE	\$ 271.49
184.5030.5238.000	Columbus Metropolitan Housing Authority	ADMIN FEE50126	\$ 99.44
184.5030.5242.000	Columbus Metropolitan Housing Authority	Rent Assistance	\$ 3,379.00
740.8065.5342.000	CONSTRUCT INC	4th&Hughes St Em Stor Sewer Rep & CO 1 12/5-5/1/26	\$ 17,454.81
884.7010.5337.000	Covenant Workplace Solutions	May EAP services	\$ 432.25
184.5030.5242.000	Crestview Apts LLC	Rent Assistance	\$ 424.00
184.5030.5242.000	Crestview Apts LLC	Rent Assistance	\$ 424.00
184.5030.5242.000	Crestview Apts LLC	Rent Assistance	\$ 455.00
184.5030.5242.000	Crestview Apts LLC	Rent Assistance	\$ 441.00
184.5030.5242.000	Crestview Apts LLC	Rent Assistance	\$ 443.00
184.5030.5242.000	Crestview Apts LLC	Rent Assistance	\$ 436.00
184.5030.5242.000	Crestview Apts LLC	Rent Assistance	\$ 439.00
184.5030.5242.000	Crestview Apts LLC	Rent Assistance	\$ 445.00
184.5030.5242.000	Crestview Apts LLC	Rent Assistance	\$ 416.00
184.5030.5242.000	Crestview Apts LLC	Rent Assistance	\$ 62.00
184.5030.5242.000	Crestview Apts LLC	Rent Assistance	\$ 422.00
184.5030.5242.000	Crestview Apts LLC	Rent Assistance	\$ 181.00
184.5030.5242.000	Crestview Apts LLC	Rent Assistance	\$ 221.00
184.5030.5242.000	Crestview Apts LLC	Rent Assistance	\$ 366.00
184.5030.5242.000	Crestview Apts LLC	Rent Assistance	\$ 368.00
184.5030.5242.000	Crestview Apts LLC	Rent Assistance	\$ 226.00
184.5030.5242.000	Crestview Apts LLC	Rent Assistance	\$ 412.00
184.5030.5242.000	Crestview Apts LLC	Rent Assistance	\$ 487.00
184.5030.5242.000	Crestview Apts LLC	Rent Assistance	\$ 416.00
184.5030.5242.000	Crestview Apts LLC	Rent Assistance	\$ 650.00
184.5030.5242.000	Crestview Apts LLC	Rent Assistance	\$ 412.00
184.5030.5242.000	Crestview Apts LLC	Rent Assistance	\$ 455.00
001.1010.5472.000	Critchlow, Cory	ILEA milease	\$ 178.50
110.2010.5617.000	CTI Ready Mix Inc	602 Union St curb repair	\$ 283.00
110.2010.5617.000	CTI Ready Mix Inc	9th and Jerome St curb repair	\$ 297.00
140.4030.5750.000	CTI Ready Mix Inc	Slider base Anson Park	\$ 374.50
140.4030.5750.000	CTI Ready Mix Inc	Glider walk Anson park	\$ 283.00
610.8016.5600.000	CTI Ready Mix Inc	Edgebrook manhole box out	\$ 395.50
740.8065.5600.000	CTI Ready Mix Inc	2nd Ave and Olive St storm sewer repair	\$ 740.50
690.8050.5565.000	CUMMINS Sales & Service	Transit #101 gaskets and hose	\$ 149.00
690.8050.5565.000	CUMMINS Sales & Service	Transit #101 gaskets and hose	\$ 218.83
184.5030.5242.000	D & D RENTALS INC	Rent Assistance	\$ 69.00
184.5030.5242.000	D & D RENTALS INC	Rent Assistance	\$ 600.00
184.5030.5242.000	D & D RENTALS INC	Rent Assistance	\$ 544.00
184.5030.5242.000	D & D RENTALS INC	Rent Assistance	\$ 316.00
184.5030.5242.000	D & D RENTALS INC	Rent Assistance	\$ 161.00
001.2080.5342.000	Dans Overhead Doors & More	Hangar #26 rebuild motor and gear box	\$ 3,104.00
184.5030.5242.000	Daters, Toni Rae	Rent Assistance	\$ 401.00
610.8015.5410.000	Daves Crane & Wrecker Service	set sludge storage tank #5 mixers	\$ 1,020.00
184.5030.5242.000	Douglas Terrace Apartments LLC	Rent Assistance	\$ 303.00
184.5030.5242.000	Douglas Terrace Apartments LLC	Rent Assistance	\$ 685.00
184.5030.5242.000	Douglas Terrace Apartments LLC	Rent Assistance	\$ 700.00
184.5030.5242.000	Ealy, Carol	Rent Assistance	\$ 523.00
364.4030.5410.000	Electric Supply of Marshalltown	Linn Creek trail head CAT-6 camera cable	\$ 1,000.00
364.4030.5410.000	Electric Supply of Marshalltown	Linn Creek trail head camera material	\$ 169.06
184.5030.5242.000	EPC LLC	Rent Assistance	\$ 357.00
184.5030.5242.000	EPC LLC	Rent Assistance	\$ 351.00
184.5030.5242.000	Etter, Connie	Rent Assistance	\$ 650.00
184.5030.5242.000	Eubanks, Chad	Rent Assistance	\$ 338.00
610.8015.5603.000	Eurofins Environment Testing America Holdngs Inc	LAB analysis- SBR#2, E-coli, #1-4 April '26	\$ 256.40
610.8016.5600.000	Fastenal Co	Sewer dept supplies	\$ 22.37
740.8065.5600.000	Fastenal Co	Sewer dept supplies	\$ 14.92
999.1125.000	Fidelity Security Life Insurance	VISION INSURANCE	\$ 342.79
999.1125.000	Fidelity Security Life Insurance	VISION INSURANCE	\$ 161.04
184.5030.5242.000	Flores, Antonio	Rent Assistance	\$ 285.00

110.2010.5233.000	Foth Infrastructure & Environment LLC	HWY 14 - North Corridor - City Design thru 3/31/26	\$ 9,524.60
184.5030.5242.000	FRIENDLY VALLEY APARTMENTS INC	Rent Assistance	\$ 64.00
184.5030.5242.000	FRIENDLY VALLEY APARTMENTS INC	Rent Assistance	\$ 101.00
184.5030.5242.000	FRIENDLY VALLEY APARTMENTS INC	Rent Assistance	\$ 161.00
001.1010.5132.000	Galls LLC	Police dept employee boots	\$ 84.21
001.1010.5132.000	Galls LLC	Police dept employee clothing	\$ 43.44
001.1050.5132.000	Galls LLC	Fire dept employee clothing	\$ 172.25
001.1050.5132.000	Galls LLC	Fire dept employee emblem	\$ 10.74
001.1050.5132.000	Galls LLC	Fire dept employee clothing	\$ 136.09
170.4010.5750.000	Garling Construction Inc	Library interior remodel	\$ 158,423.72
181.3040.5410.000	Gentry, Susan	810 N 5th Ave	\$ 55,575.00
181.3040.5415.000	Gentry, Susan	810 N 5th Ave	\$ 12,500.00
999.1166.000	Giannetto, Antonio	Overpaid parking ticket	\$ 25.00
690.8050.5565.000	GILLIG LLC	Transit #014 windshield	\$ 503.55
690.8050.5565.000	GILLIG LLC	Transit #131 rear bumper	\$ 1,844.07
184.5030.5242.000	Glenda Drive LLC	Rent Assistance	\$ 391.00
184.5030.5242.000	Glenda Drive LLC	Rent Assistance	\$ 321.00
184.5030.5242.000	Glenda Drive LLC	Rent Assistance	\$ 403.00
184.5030.5242.000	Gonzalez, Renato	Rent Assistance	\$ 621.00
184.5030.5242.000	Gorrell, Joseph	Rent Assistance	\$ 650.00
184.5030.5242.000	Gray, Dennis	Rent Assistance	\$ 483.00
184.5030.5242.000	Gray, Dennis	Rent Assistance	\$ 638.00
610.8015.5450.000	Greazel, Lance	CELL PHONE STIPEND	\$ 40.00
110.2010.5618.000	GRIMES ASPHALT AND PAVING CORP.	Street dept cold mix	\$ 1,088.10
184.5030.5242.000	Hala, Janet	Rent Assistance	\$ 167.00
184.5030.5242.000	Hala, Janet	Rent Assistance	\$ 168.00
184.5030.5242.000	Hala, Janet	Rent Assistance	\$ 416.00
184.5030.5242.000	Hala, Janet	Rent Assistance	\$ 324.00
184.5030.5242.000	Hala, Janet	Rent Assistance	\$ 304.00
690.8050.5565.000	HANNAM AUTOMOTIVE LLC	Transit #101 paint panel	\$ 800.00
884.7010.5337.000	HARTFORD- PRIORITY ACCTS	May insurance premium	\$ 7,047.60
913.1013.5337.000	HARTFORD- PRIORITY ACCTS	May insurance premium	\$ 571.17
184.5030.5242.000	Hatch, Roger	Rent Assistance	\$ 428.00
184.5030.5242.000	Hatch, Roger	Rent Assistance	\$ 955.00
184.5030.5242.000	HAVELKA, BILL S	Rent Assistance	\$ 696.00
001.1099.5450.000	HEART OF IOWA COMMUNICATIONS CO-OP	Police & Fire Bldg	\$ 2,229.09
001.4045.5450.000	HEART OF IOWA COMMUNICATIONS CO-OP	Aquatic Center	\$ 10.00
001.4065.5450.000	HEART OF IOWA COMMUNICATIONS CO-OP	Coliseum	\$ 31.00
001.6050.5450.000	HEART OF IOWA COMMUNICATIONS CO-OP	Flat rate 3204, 3390, 3399	\$ 0.85
001.6050.5450.000	HEART OF IOWA COMMUNICATIONS CO-OP	e-bill incentive credit	\$ (1.00)
001.6050.5450.000	HEART OF IOWA COMMUNICATIONS CO-OP	City Hall	\$ 244.09
110.2010.5450.000	HEART OF IOWA COMMUNICATIONS CO-OP	PW Bldg	\$ 86.04
610.8015.5450.000	HEART OF IOWA COMMUNICATIONS CO-OP	Direct connect internet PW/WPCP	\$ 522.45
610.8015.5450.000	HEART OF IOWA COMMUNICATIONS CO-OP	WPCP	\$ 86.04
610.8016.5450.000	HEART OF IOWA COMMUNICATIONS CO-OP	Direct connect internet PW/WPCP	\$ 313.47
610.8016.5450.000	HEART OF IOWA COMMUNICATIONS CO-OP	WPCP	\$ 51.63
610.8016.5450.000	HEART OF IOWA COMMUNICATIONS CO-OP	PW Bldg	\$ 51.63
740.8065.5450.000	HEART OF IOWA COMMUNICATIONS CO-OP	Direct connect internet PW/WPCP	\$ 208.98
740.8065.5450.000	HEART OF IOWA COMMUNICATIONS CO-OP	PW Bldg	\$ 34.42
740.8065.5450.000	HEART OF IOWA COMMUNICATIONS CO-OP	WPCP	\$ 34.42
184.5030.5242.000	HESSENIUS, ROBERT	Rent Assistance	\$ 615.00
184.5030.5242.000	Hilltop Village Inc	Rent Assistance	\$ 253.00
184.5030.5242.000	Hilltop Village Inc	Rent Assistance	\$ 217.00
184.5030.5242.000	Historic Tallcorn Towers LLP	Rent Assistance	\$ 267.00
184.5030.5242.000	Historic Tallcorn Towers LLP	Rent Assistance	\$ 271.00
184.5030.5242.000	Historic Tallcorn Towers LLP	Rent Assistance	\$ 291.00
184.5030.5242.000	Historic Tallcorn Towers LLP	Rent Assistance	\$ 294.00
184.5030.5242.000	Historic Tallcorn Towers LLP	Rent Assistance	\$ 299.00
184.5030.5242.000	Historic Tallcorn Towers LLP	Rent Assistance	\$ 318.00
184.5030.5242.000	Historic Tallcorn Towers LLP	Rent Assistance	\$ 152.00
184.5030.5242.000	Historic Tallcorn Towers LLP	Rent Assistance	\$ 382.00
184.5030.5242.000	Historic Tallcorn Towers LLP	Rent Assistance	\$ 422.00
184.5030.5242.000	Historic Tallcorn Towers LLP	Rent Assistance	\$ 450.00
184.5030.5242.000	Historic Tallcorn Towers LLP	Rent Assistance	\$ 304.00
184.5030.5242.000	Historic Tallcorn Towers LLP	Rent Assistance	\$ 326.00
184.5030.5242.000	Ho Phi Nguyen	Rent Assistance	\$ 550.00

690.8050.5410.000	Holmes Radiator	Transit #101 DPF & DOC filter water cleaning	\$ 449.00
690.8050.5565.000	Holmes Radiator	Transit #101 DPF & DOC filter water cleaning	\$ 155.00
153.1010.5321.000	Hometown Veterinarian	Atlas appointment and meds	\$ 29.70
153.1010.5321.000	Hometown Veterinarian	Atlas appointment and meds	\$ 55.16
153.1010.5321.000	Hometown Veterinarian	Atlas appointment and meds	\$ 1,178.12
610.8015.5410.000	HOTSYS CLEANING SYSTEMS INC	Equipment service maint	\$ 512.70
184.5030.5242.000	House Harvesters LLC	Rent Assistance	\$ 299.00
110.2012.5233.000	HOWARD R GREEN COMPANY, INC	2026 Street Rehabilitation - HMA thru 4/17/26	\$ 7,700.00
610.8015.5233.000	HOWARD R GREEN COMPANY, INC	WPC Sludge Thick Add Design & Cons thru 4/17/26	\$ 11,684.80
615.8015.5233.000	HOWARD R GREEN COMPANY, INC	SBR Optimization and Improv Study thru 4/17/26	\$ 3,990.00
615.8015.5233.000	HOWARD R GREEN COMPANY, INC	Industrial Conveyance FEB Design 4/17/26	\$ 20,111.45
184.5030.5242.000	Howard, Jammie	Rent Assistance	\$ 164.00
001.4066.5290.000	ICAP	Coliseum liquor liability ins 6/1/26-5/31/27	\$ 2,019.00
001.1099.5450.000	IMON Communications LLC	Police and Fire internet	\$ 134.99
184.5030.5242.000	Inman, Jeffrey	Rent Assistance	\$ 142.00
999.1101.000	INTERNAL REVENUE SERVICE	Bi-Weekly Federal Taxes	\$ 30,974.56
999.1101.000	INTERNAL REVENUE SERVICE	Bi-Weekly Federal Taxes	\$ 16,118.03
999.1103.000	INTERNAL REVENUE SERVICE	Bi-Weekly Payroll Social Security	\$ 32,087.20
999.1103.000	INTERNAL REVENUE SERVICE	Bi-Weekly Payroll Social Security	\$ 6,771.40
999.1107.000	INTERNAL REVENUE SERVICE	Bi-Weekly Payroll Medicare	\$ 10,484.06
999.1107.000	INTERNAL REVENUE SERVICE	Bi-Weekly Payroll Medicare	\$ 5,125.62
001.4045.5251.000	Iowa Dept of Inspections, Appeals, Licensing	Aquatic Center boiler inspection	\$ 40.00
001.4066.5251.000	Iowa Dept of Inspections, Appeals, Licensing	Coliseum food service license	\$ 150.00
610.8016.5230.000	IOWA ONE CALL	March Sewer location services	\$ 299.34
740.8065.5230.000	IOWA ONE CALL	March Sewer location services	\$ 199.56
110.2010.5626.000	IOWA PRISON INDUSTRIES	Street signs/ supplies	\$ 120.00
001.2080.5483.000	Iowa Regional Utilities Association	Airport water	\$ 204.56
184.5030.5242.000	JB COOP ASSOCIATION	Rent Assistance	\$ 355.00
184.5030.5242.000	JB COOP ASSOCIATION	Rent Assistance	\$ 451.00
184.5030.5242.000	JB COOP ASSOCIATION	Rent Assistance	\$ 408.00
184.5030.5242.000	JB COOP ASSOCIATION	Rent Assistance	\$ 408.00
184.5030.5242.000	JB COOP ASSOCIATION	Rent Assistance	\$ 415.00
184.5030.5242.000	JB COOP ASSOCIATION	Rent Assistance	\$ 490.00
184.5030.5242.000	JDL Rentals Cooperative	Rent Assistance	\$ 490.00
184.5030.5242.000	Jimenez, Luis	Rent Assistance	\$ 358.00
184.5030.5242.000	Kading Properties LLC	Rent Assistance	\$ 738.00
184.5030.5242.000	Kading Properties LLC	Rent Assistance	\$ 491.00
184.5030.5242.000	Kading Properties LLC	Rent Assistance	\$ 609.00
184.5030.5242.000	Kading Properties LLC	Rent Assistance	\$ 1,024.00
139.4045.5342.000	KAPAUN & BROWN INC	Pleasant Hill Pool heat repairs	\$ 962.71
140.4030.5750.000	KAY PARK-REC CORP	6" recycled plastic countour bench	\$ 1,315.75
001.1010.5610.000	Kiesler Police Supply	Police dept ammunition	\$ 1,439.58
184.5030.5242.000	Kramer, Marcia	Rent Assistance	\$ 388.00
110.2010.5570.000	KWIK Trip Inc	Street dept premium fuel	\$ 177.07
001.1010.5431.000	Language Line Services Inc	Over the phone interrpretations	\$ 58.50
184.5030.5242.000	Lawthers Property Management	Rent Assistance	\$ 156.00
110.2010.5450.000	Legg, Richard	CELLPHONE STIPEND	\$ 40.00
184.5030.5242.000	Linton, Tyler	Rent Assistance	\$ 351.00
184.5030.5242.000	Linton, Tyler	Rent Assistance	\$ 292.00
184.5030.5246.000	Louis, Marie	Rent Assistance	\$ 7.00
184.5030.5242.000	Luense, Brant	Rent Assistance	\$ 661.00
184.5030.5242.000	Luense, Brant	Rent Assistance	\$ 347.00
184.5030.5242.000	Luense, Brant	Rent Assistance	\$ 260.00
184.5030.5242.000	Luense, Brant	Rent Assistance	\$ 212.00
184.5030.5242.000	Luense, Brant	Rent Assistance	\$ 547.00
184.5030.5242.000	Luense, Brant	Rent Assistance	\$ 750.00
184.5030.5242.000	Lusoma LLC	Rent Assistance	\$ 229.00
184.5030.5242.000	Lusoma LLC	Rent Assistance	\$ 397.00
001.1010.5410.000	MACQUEEN EQUIPMENT	Antenna installation	\$ 5,544.28
001.1010.5565.000	MACQUEEN EQUIPMENT	PD docking station for tablet	\$ 778.05
030.1010.5718.000	MACQUEEN EQUIPMENT	CIP vehicle lighting	\$ 700.00
030.1010.5718.000	MACQUEEN EQUIPMENT	PD basic emergency vehicle equipment	\$ 4,400.00
030.1010.5750.000	MACQUEEN EQUIPMENT	CIP Vehicle Installation	\$ 18,275.58
030.1010.5750.000	MACQUEEN EQUIPMENT	CIP Vehicle Installation	\$ (2,022.00)
030.1010.5750.000	MACQUEEN EQUIPMENT	CIP Vehicle lighting	\$ 6,369.39
153.1010.5321.000	MACQUEEN EQUIPMENT	K9 vehicle lighting	\$ 3,490.00
153.1010.5321.000	MACQUEEN EQUIPMENT	MPD K9 Truck Upfit	\$ 20,244.41

001.6070.5342.000	Marco Holdings LLC	Admin outbound call ring issue	\$	427.50
001.6070.5342.000	Marco Holdings LLC	Admin outbound call ring issue	\$	950.00
001.1010.5570.000	Marshall County Engineer	Fuel Purchases	\$	6,133.16
001.1010.5570.000	Marshall County Engineer	Fuel Purchases	\$	145.18
001.1050.5570.000	Marshall County Engineer	Fuel Purchases	\$	501.86
001.1050.5571.000	Marshall County Engineer	Fuel Purchases	\$	948.73
001.1071.5570.000	Marshall County Engineer	Fuel Purchases	\$	26.00
001.1075.5570.000	Marshall County Engineer	Fuel Purchases	\$	89.82
001.2020.5570.000	Marshall County Engineer	Fuel Purchases	\$	39.33
001.4030.5570.000	Marshall County Engineer	Fuel Purchases	\$	715.97
001.4030.5571.000	Marshall County Engineer	Fuel Purchases	\$	532.58
001.6050.5570.000	Marshall County Engineer	Fuel Purchases	\$	96.00
110.2010.5570.000	Marshall County Engineer	Fuel Purchases	\$	843.61
110.2010.5571.000	Marshall County Engineer	Fuel Purchases	\$	2,367.51
110.2040.5570.000	Marshall County Engineer	Fuel Purchases	\$	237.93
110.2060.5570.000	Marshall County Engineer	Fuel Purchases	\$	409.13
110.2070.5571.000	Marshall County Engineer	Fuel Purchases	\$	1,263.57
610.8015.5570.000	Marshall County Engineer	Fuel Purchases	\$	187.23
610.8016.5570.000	Marshall County Engineer	Fuel Purchases	\$	353.65
610.8016.5571.000	Marshall County Engineer	Fuel Purchases	\$	347.50
690.8050.5570.000	Marshall County Engineer	Fuel Purchases	\$	257.65
690.8050.5571.000	Marshall County Engineer	Fuel Purchases	\$	5,872.56
740.8065.5570.000	Marshall County Engineer	Fuel Purchases	\$	235.77
740.8065.5571.000	Marshall County Engineer	Fuel Purchases	\$	231.66
110.2010.5342.000	Marshall County Landfill	Street dept used tires	\$	40.00
184.5030.5242.000	Marshalltown Lofts, LLC	Rent Assistance	\$	54.00
184.5030.5242.000	Marshalltown Lofts, LLC	Rent Assistance	\$	274.00
184.5030.5242.000	Marshalltown Lofts, LLC	Rent Assistance	\$	253.00
184.5030.5242.000	Marshalltown Lofts, LLC	Rent Assistance	\$	251.00
184.5030.5242.000	Marshalltown Lofts, LLC	Rent Assistance	\$	303.00
184.5030.5242.000	Marshalltown Lofts, LLC	Rent Assistance	\$	340.00
184.5030.5242.000	Marshalltown Lofts, LLC	Rent Assistance	\$	455.00
184.5030.5242.000	Marshalltown Lofts, LLC	Rent Assistance	\$	241.00
184.5030.5242.000	Marshalltown Lofts, LLC	Rent Assistance	\$	228.00
184.5030.5242.000	Marshalltown Lofts, LLC	Rent Assistance	\$	190.00
184.5030.5242.000	Marshalltown Lofts, LLC	Rent Assistance	\$	111.00
184.5030.5242.000	Marshalltown Lofts, LLC	Rent Assistance	\$	297.00
184.5030.5242.000	Marshalltown Lofts, LLC	Rent Assistance	\$	710.00
184.5030.5242.000	Marshalltown Lofts, LLC	Rent Assistance	\$	898.00
184.5030.5242.000	Marshalltown Lofts, LLC	Rent Assistance	\$	685.00
001.1099.5483.000	Marshalltown Water Works	Police & Fire dept water	\$	68.84
001.4030.5483.000	Marshalltown Water Works	water	\$	17.51
001.4030.5483.000	Marshalltown Water Works	Riverview Park water	\$	17.51
001.4030.5483.000	Marshalltown Water Works	City RV Dump water	\$	17.51
001.4030.5483.000	Marshalltown Water Works	water	\$	28.06
001.4030.5483.000	Marshalltown Water Works	water	\$	20.99
001.4030.5483.000	Marshalltown Water Works	6th St complex MFL	\$	14.03
001.4030.5483.000	Marshalltown Water Works	water	\$	94.07
001.4030.5483.000	Marshalltown Water Works	Riverview Hydrant 1001 Woodland St	\$	17.51
001.4065.5483.000	Marshalltown Water Works	Coliseum water	\$	111.08
142.4030.5483.000	Marshalltown Water Works	water	\$	29.44
142.4030.5483.000	Marshalltown Water Works	water	\$	29.44
110.2010.5620.000	Martin Marietta Materials	Street dept crushed rock	\$	400.41
110.2010.5620.000	Martin Marietta Materials	Street dept crushed rock	\$	754.11
110.2010.5620.000	Martin Marietta Materials	Street dept crushed rock	\$	364.23
184.5030.5246.000	Mattingly, Ruth	Rent Assistance	\$	40.00
312.2080.5233.000	McClure Engineering Co	Airport Master Plan 3/29/26-4/25/26	\$	10,207.75
184.5030.5242.000	MD Kruse Enterprise	Rent Assistance	\$	90.00
001.4010.5410.000	MENARDS	Building repairs caulking	\$	7.78
001.4030.5410.000	MENARDS	MSA concession stand repairs	\$	4.49
001.4030.5609.000	MENARDS	DNR park fertilizer	\$	25.98
001.4030.5611.000	MENARDS	screws and rebar	\$	187.00
001.4030.5611.000	MENARDS	Anson Park supplies	\$	7.90
001.4030.5611.000	MENARDS	Titanium shears, utility knives, concrete mix	\$	106.73
001.4030.5611.000	MENARDS	DNR park fertilizer	\$	2.49
001.4045.5410.000	MENARDS	Aquatic Center pump gaskets	\$	17.98

001.4045.5410.000	MENARDS	Aquatic center water line repair supplies	\$	15.51
001.4045.5410.000	MENARDS	Aquatic Center shut off valve	\$	23.99
001.4045.5410.000	MENARDS	Aquatic Center shower water line repair	\$	12.97
001.6050.5410.000	MENARDS	Building repairs caulking	\$	7.78
001.6051.5410.000	MENARDS	Building repairs caulking	\$	4.88
110.2010.5718.000	MENARDS	Garden hose, push brooms	\$	34.98
110.2010.5718.000	MENARDS	6 pc SS pick set	\$	4.99
364.4030.5410.000	MENARDS	Linn Creek Trailhead camera supplies	\$	36.57
610.8015.5603.000	Microbac Laboratories Inc	LAB analysis Dig #3 & hauling	\$	331.00
364.2010.5342.000	Mid-Iowa Enterprises LLC	HMA Crack and Joint Seal 4/4/26-5/1/26	\$	38,241.92
610.8015.5603.000	MIDLAND SCIENTIFIC INC	LAB 500ml cylinder	\$	37.11
001.1050.5344.000	Midwest Office Technology	Fire dept copier rental and copies	\$	149.95
030.4030.5718.000	MIRACLE RECREATION	timber 6' Lx12" H recycled	\$	3,181.38
999.1131.000	Mission Square Retirement- 303417	Mission Square Retirement - Plan #303417	\$	1,470.90
999.1131.000	Mission Square Retirement- 303417	ICMA DEFERRED COMP - Plan #303417	\$	231.74
999.1131.000	Mission Square Retirement- 303417	Mission Square Retirement - Plan #303417ICMA DEF C	\$	7,288.62
999.1131.000	Mission Square Retirement- 303417	ICMA DEF COMP	\$	230.76
999.1131.000	Mission Square Retirement- 303417	Mission Square Retirement - Plan #705230	\$	1,429.77
999.1131.000	Mission Square Retirement- 303417	Mission Square Retirement - Plan #705230	\$	2,618.84
999.1131.000	Mission Square Retirement- 303417	Mission Square Retirement - 457b Plan #303417	\$	100.00
999.1131.000	Mission Square Retirement- 303417	Mission Square Retirement - Plan #303417ICMA DEF C	\$	1,325.00
999.1131.000	Mission Square Retirement- 303417	ICMA DEF COMP	\$	269.23
999.1131.000	Mission Square Retirement- 303417	Mission Square Retirement - Plan #705230	\$	143.73
999.1131.000	Mission Square Retirement- 303417	Mission Square Retirement - Plan #705230	\$	963.46
999.1131.000	Mission Square Retirement- 303417	Mission Square Retirement - Plan #705230	\$	795.00
110.2040.5780.000	MOBOTREX INC	Replacement Camera Detec for Traf Signal- Main/3rd	\$	21,179.00
184.5030.5242.000	MOJO Rentals	Rent Assistance	\$	311.00
184.5030.5242.000	Moore, Michelle	Rent Assistance	\$	295.00
184.5030.5242.000	Mtown/ Westown LLLP	Rent Assistance	\$	382.00
184.5030.5242.000	Mtown/ Westown LLLP	Rent Assistance	\$	382.00
184.5030.5242.000	Mtown/ Westown LLLP	Rent Assistance	\$	385.00
184.5030.5242.000	Mtown/ Westown LLLP	Rent Assistance	\$	388.00
184.5030.5242.000	Mtown/ Westown LLLP	Rent Assistance	\$	390.00
184.5030.5242.000	Mtown/ Westown LLLP	Rent Assistance	\$	227.00
184.5030.5242.000	Mtown/ Westown LLLP	Rent Assistance	\$	376.00
184.5030.5242.000	Mtown/ Westown LLLP	Rent Assistance	\$	372.00
184.5030.5242.000	Mtown/ Westown LLLP	Rent Assistance	\$	154.00
184.5030.5242.000	Mtown/ Westown LLLP	Rent Assistance	\$	231.00
184.5030.5242.000	Mtown/ Westown LLLP	Rent Assistance	\$	239.00
184.5030.5242.000	Mtown/ Westown LLLP	Rent Assistance	\$	248.00
184.5030.5242.000	Mtown/ Westown LLLP	Rent Assistance	\$	377.00
184.5030.5242.000	Mtown/ Westown LLLP	Rent Assistance	\$	288.00
184.5030.5242.000	Mtown/ Westown LLLP	Rent Assistance	\$	278.00
184.5030.5242.000	Mtown/ Westown LLLP	Rent Assistance	\$	289.00
184.5030.5242.000	Mtown/ Westown LLLP	Rent Assistance	\$	324.00
184.5030.5242.000	Mtown/ Westown LLLP	Rent Assistance	\$	152.00
184.5030.5242.000	Mtown/ Westown LLLP	Rent Assistance	\$	359.00
184.5030.5242.000	Mtown/ Westown LLLP	Rent Assistance	\$	346.00
142.4030.5342.000	Musco Sports Lighting	000	\$	13,500.00
184.5030.5242.000	Ndihokubwayo, Levis	Rent Assistance	\$	299.00
610.8015.5600.000	Nebraska Air Filter Inc	Air filters for MAU	\$	1,669.46
184.5030.5242.000	NORTH TAMA HOUSING, INC	Rent Assistance	\$	51.00
110.2010.5600.000	Nutrien AG Solutions Inc	Street dept DEF fluid	\$	243.80
184.5030.5242.000	Oetker, Debra	Rent Assistance	\$	55.00
184.5030.5242.000	Oetker, Debra	Rent Assistance	\$	93.00
184.5030.5242.000	Oetker, Debra	Rent Assistance	\$	330.00
001.1010.5605.000	OFFICE EXPRESS	PD office supplies	\$	38.44
001.1010.5605.000	OFFICE EXPRESS	PD self inking stamp	\$	21.99
001.4040.5216.000	One Source Aquisition Company LLC	application checks	\$	19.00
690.8050.5216.000	One Source Aquisition Company LLC	application checks	\$	41.00
184.5030.5242.000	Park Elms LLC	Rent Assistance	\$	195.00
184.5030.5242.000	Park Elms LLC	Rent Assistance	\$	666.00
184.5030.5242.000	Park Elms LLC	Rent Assistance	\$	107.00
184.5030.5242.000	Park Elms LLC	Rent Assistance	\$	397.00
184.5030.5246.000	Patton, Camille	Rent Assistance	\$	46.00
Payroll	Payroll	Payroll #9 5.7.26	\$	386,600.42

610.8015.5344.000	PerkinElmer US LLC	Lab PinAAcle 900T service plan	\$	10,724.40
610.8015.5347.000	PerkinElmer US LLC	Lab PinAAcle 900T software	\$	1,382.40
001.6025.5450.000	Petermeier, Jill	CELLPHONE STIPEND	\$	40.00
184.5030.5242.000	PHR Properties LLC	Rent Assistance	\$	320.00
140.4030.5611.000	Plumb Supply	campground shower trim, valve	\$	161.67
184.5030.5242.000	Plymat Jr , William	Rent Assistance	\$	546.00
001.1099.5342.000	Prairie Waste Solutions	Police and Fire Bldg	\$	128.46
001.4010.5342.000	Prairie Waste Solutions	Library	\$	124.98
001.4030.5342.000	Prairie Waste Solutions	Public Works Bldg 905 E Main	\$	25.69
001.4030.5342.000	Prairie Waste Solutions	Bullpen- Parks dept Woodland Dr	\$	102.74
001.4030.5342.000	Prairie Waste Solutions	Park Roll Offs	\$	246.86
001.6050.5342.000	Prairie Waste Solutions	City Hall and Carnegie Bldg	\$	64.23
001.6051.5342.000	Prairie Waste Solutions	City Hall and Carnegie Bldg	\$	64.23
110.2010.5342.000	Prairie Waste Solutions	Public Works Bldg 905 E Main	\$	51.39
610.8015.5342.000	Prairie Waste Solutions	Water Pollution plant	\$	128.46
610.8015.5342.000	Prairie Waste Solutions	April '26 grit/ screening removal	\$	226.60
690.8050.5342.000	Prairie Waste Solutions	Public Works Bldg 905 E Main	\$	51.38
184.5030.5242.000	Premier Iowa City IA LLC	Rent Assistance	\$	86.00
184.5030.5242.000	Premier Iowa City IA LLC	Rent Assistance	\$	193.00
184.5030.5242.000	Premier Iowa City IA LLC	Rent Assistance	\$	274.00
184.5030.5242.000	Premier Iowa City IA LLC	Rent Assistance	\$	392.00
184.5030.5242.000	Premier Iowa City IA LLC	Rent Assistance	\$	655.00
184.5030.5242.000	Premier Marshalltown IA LLC	Rent Assistance	\$	762.00
184.5030.5242.000	Premier Marshalltown IA LLC	Rent Assistance	\$	42.00
184.5030.5242.000	Premier Marshalltown IA LLC	Rent Assistance	\$	414.00
184.5030.5242.000	Premier Marshalltown IA LLC	Rent Assistance	\$	433.00
184.5030.5344.000	Premier Office Equipment	Housing contract and copies	\$	74.64
001.1050.5410.000	Pro Hydro-testing LLC	- Escape Cylinder Testing	\$	4,620.00
184.5030.5242.000	Pyramid Property Solutions Inc	Rent Assistance	\$	312.00
184.5030.5242.000	Pyramid Property Solutions Inc	Rent Assistance	\$	35.00
184.5030.5242.000	Pyramid Property Solutions Inc	Rent Assistance	\$	404.00
184.5030.5242.000	R & A Rental Properties LLC	Rent Assistance	\$	443.00
184.5030.5242.000	R & A Rental Properties LLC	Rent Assistance	\$	592.00
001.1010.5600.000	RACOM CORPORATION	LI-ION batteries	\$	1,312.50
001.1050.5718.000	RACOM CORPORATION	Li-ion battery	\$	131.25
032.1050.5703.000	RACOM CORPORATION	Rescue project radio setup and programming	\$	5,091.70
610.8015.5450.000	Ranson, Robert	CELLPHONE STIPEND	\$	40.00
121.5040.5230.000	RDG Planning & Design	Comp Plan and Housing Study Res 2025-082	\$	15,717.00
121.5040.5230.000	RDG Planning & Design	Comp Plan and Housing Study Res 2025-082	\$	20,646.68
121.5040.5230.000	RDG Planning & Design	Comp Plan and Housing Study Res 2025-082	\$	20,817.07
184.5030.5242.000	Redborg, Kirsten	Rent Assistance	\$	376.00
184.5030.5242.000	Reed, Tony	Rent Assistance	\$	422.00
133.5010.5230.000	Region 6 Resource Partners	Marshalltown Tree planting CDBG derecho 145	\$	205.00
184.5030.5246.000	Reiong, Elizabeth	Rent Assistance	\$	77.00
184.5030.5242.000	Rice, Quinton	Rent Assistance	\$	403.00
184.5030.5242.000	River Birch Apts	Rent Assistance	\$	298.00
184.5030.5242.000	River Oaks Apartments	Rent Assistance	\$	515.00
184.5030.5242.000	River Oaks Apartments	Rent Assistance	\$	456.00
184.5030.5242.000	River Oaks Apartments	Rent Assistance	\$	195.00
184.5030.5242.000	River Oaks Apartments	Rent Assistance	\$	525.00
184.5030.5242.000	RMB Cooperative	Rent Assistance	\$	501.00
184.5030.5242.000	RMB Cooperative	Rent Assistance	\$	1,000.00
184.5030.5242.000	Rural Revival Properties LLC	Rent Assistance	\$	320.00
001.1071.5342.000	Safe Building	Rental Inspection Service Agreement FY26/27	\$	7,320.00
001.1071.5342.000	Safe Building	Rental Inspection Service Agreement FY26/27	\$	6,460.00
610.8015.5380.000	SCHARNWEBER WATER CONDITIONING INC	WPCP Water conditioner lease	\$	27.00
001.4030.5342.000	SCHENDEL PEST CONTROL INC	City Hall/ Carnegie Bldg/ Parks office	\$	22.90
001.4065.5342.000	SCHENDEL PEST CONTROL INC	Coliseum	\$	52.04
001.6050.5342.000	SCHENDEL PEST CONTROL INC	City Hall/ Carnegie Bldg/ Parks office	\$	22.90
001.6051.5342.000	SCHENDEL PEST CONTROL INC	City Hall/ Carnegie Bldg/ Parks office	\$	23.58
001.1010.5472.000	Schmelzer, Hunter	ILEA weeks 14-16	\$	178.50
184.5030.5242.000	Schmidt, Michael T	Rent Assistance	\$	372.00
184.5030.5242.000	Schmidt, Michael T	Rent Assistance	\$	700.00
110.2010.5386.000	Scrap and More LLC	Mowings 4/21 and 4/27	\$	190.00
690.8050.5370.000	Sho Biz Inc dba Minuteman	NCR forms	\$	22.46
140.4030.5611.000	SIGN CREATIONS	Decals and campground sign	\$	195.00

140.4030.5611.000	SMI Co	Anson project glider	\$	2,085.00
184.5030.5246.000	Squires, Christina	Rent Assistance	\$	86.00
999.1161.000	St Francis of Assis Parish	overpayment on fire permit	\$	5.00
153.1010.5321.000	Steckelberg Vet Clinic	K9 Timber annual check up	\$	323.45
184.5030.5344.000	Stericycle Inc	Housing shredding services	\$	75.92
001.4010.5342.000	STERLING FIRE & SAFETY INC	Library annual inspection	\$	520.00
001.6050.5342.000	STERLING FIRE & SAFETY INC	City Hall/ Carnegie annual inspection	\$	56.00
001.6051.5342.000	STERLING FIRE & SAFETY INC	City Hall/ Carnegie annual inspection	\$	80.00
184.5030.5246.000	Stiegelmeier, Curtis	Rent Assistance	\$	10.00
140.4030.5611.000	Strands	paint and primer Comm Room	\$	126.55
999.1164.000	STREICHERS INC	PD Employee name tag	\$	10.00
184.5030.5242.000	Superior Rentals LLC	Rent Assistance	\$	214.00
184.5030.5242.000	Superior Rentals LLC	Rent Assistance	\$	198.00
184.5030.5242.000	Superior Rentals LLC	Rent Assistance	\$	308.00
184.5030.5242.000	Superior Rentals LLC	Rent Assistance	\$	185.00
184.5030.5242.000	Superior Rentals LLC	Rent Assistance	\$	327.00
184.5030.5242.000	Superior Rentals LLC	Rent Assistance	\$	282.00
184.5030.5242.000	Sweet Pea	Rent Assistance	\$	230.00
184.5030.5242.000	Sweet Pea	Rent Assistance	\$	616.00
184.5030.5242.000	Swift, Scott	Rent Assistance	\$	430.00
184.5030.5242.000	Taylor, Mike	Rent Assistance	\$	350.00
110.2010.5132.000	THEISENS SUPPLY INC	Street dept gloves	\$	15.99
110.2010.5132.000	THEISENS SUPPLY INC	Street employee work clothes	\$	259.91
110.2010.5132.000	THEISENS SUPPLY INC	Street dept employee clothing	\$	49.99
110.2010.5600.000	THEISENS SUPPLY INC	Wood bit, mounts to gate wheel, 20' gate	\$	393.97
110.2010.5718.000	THEISENS SUPPLY INC	ratchet strap, 20" brush, lock box	\$	152.97
110.2010.5718.000	THEISENS SUPPLY INC	Street dept tool box	\$	33.00
110.2010.5718.000	THEISENS SUPPLY INC	Brushless blower	\$	179.00
610.8016.5132.000	THEISENS SUPPLY INC	Sewer dept employee boots	\$	110.99
610.8016.5600.000	THEISENS SUPPLY INC	concrete mix	\$	17.96
610.8016.5600.000	THEISENS SUPPLY INC	Sewer dept operating supplies	\$	24.80
740.8065.5132.000	THEISENS SUPPLY INC	Sewer dept employee boots	\$	74.00
740.8065.5600.000	THEISENS SUPPLY INC	concrete mix	\$	11.98
740.8065.5600.000	THEISENS SUPPLY INC	Sewer dept operating supplies	\$	16.53
001.4030.5251.000	Titus, Kristin	CDL license	\$	64.00
001.1010.5450.000	T-Mobile	PD monthly service fee	\$	52.50
001.1010.5450.000	T-Mobile	PD monthly service fee	\$	52.50
001.1010.5450.000	T-Mobile	PD cell phone services	\$	1,222.99
001.1070.5450.000	T-Mobile	DIRECT LINES HOUSING DIRECTOR	\$	5.00
001.1070.5450.000	T-Mobile	DIRECT LINES ASST HSG DIRECTOR	\$	7.14
001.1071.5450.000	T-Mobile	DIRECT LINES RENTAL INSPEC	\$	35.70
001.1071.5450.000	T-Mobile	DIRECT LINES RENTAL IPAD	\$	22.07
001.1071.5450.000	T-Mobile	DIRECT LINES ASST HSG DIRECTOR	\$	7.14
001.1071.5450.000	T-Mobile	DIRECT LINES HOUSING DIRECTOR	\$	5.00
001.1075.5450.000	T-Mobile	DIRECT LINES NUISANCE	\$	17.85
001.1075.5450.000	T-Mobile	DIRECT LINES ASST HSG DIRECTOR	\$	7.14
001.1075.5450.000	T-Mobile	DIRECT LINES - NUISANCE	\$	35.70
001.1075.5450.000	T-Mobile	DIRECT LINES HOUSING DIRECTOR	\$	5.00
001.2020.5450.000	T-Mobile	DIRECT LINES HOUSING DIRECTOR	\$	5.00
001.2020.5450.000	T-Mobile	DIRECT LINES ASST HSG DIRECTOR	\$	7.14
001.2020.5450.000	T-Mobile	DIRECT LINES NUISANCE	\$	17.85
001.4030.5450.000	T-Mobile	DIRECT LINES PARK & REC	\$	35.70
001.5040.5450.000	T-Mobile	DIRECT LINES ASST HSG DIRECTOR	\$	7.14
001.5040.5450.000	T-Mobile	DIRECT LINES HOUSING DIRECTOR	\$	5.00
110.2010.5450.000	T-Mobile	DIRECT LINES MECHANIC	\$	22.07
110.2010.5450.000	T-Mobile	DIRECT LINES SIGN SHOP	\$	22.07
110.2040.5450.000	T-Mobile	DIRECT LINES UTILITY	\$	35.70
110.2060.5450.000	T-Mobile	DIRECT LINES PW IPAD	\$	6.18
110.2060.5450.000	T-Mobile	DIRECT LINES SURVEY GPS	\$	31.85
110.2060.5450.000	T-Mobile	DIRECT LINES ENGINEERING	\$	31.85
110.2060.5450.000	T-Mobile	DIRECT LINES PW DIRECTOR	\$	35.70
181.3040.5450.000	T-Mobile	DIRECT LINES HOUSING DIRECTOR	\$	2.50
184.5030.5450.000	T-Mobile	DIRECT LINES HOUSING DIRECTOR	\$	8.20
610.8015.5450.000	T-Mobile	DIRECT LINES WPCP OPER	\$	35.70
610.8015.5450.000	T-Mobile	DIRECT LINES HOT SPOT SEWER	\$	19.11
610.8016.5450.000	T-Mobile	DIRECT LINES PW IPAD	\$	9.49

610.8016.5450.000	T-Mobile	DIRECT LINES TROY MCGAUGHEY	\$	21.42
610.8016.5450.000	T-Mobile	DIRECT LINES HOT SPOT	\$	19.11
740.8065.5450.000	T-Mobile	DIRECT LINES HOT SPOT	\$	12.74
740.8065.5450.000	T-Mobile	DIRECT LINES HOT SPOT SEWER	\$	12.74
740.8065.5450.000	T-Mobile	DIRECT LINES PW IPAD	\$	6.40
740.8065.5450.000	T-Mobile	DIRECT LINES TROY MCGAUGHEY	\$	14.28
110.2010.5352.000	Top Notch Tree Service Inc	1918 S 5th Ave tree removal	\$	950.00
355.1075.5264.000	Top Notch Tree Service Inc	Top Notch Tree Service Inc 1918 S 5th Ave	\$	16,800.00
999.1128.000	TOTAL ADMINISTRATIVE SERVICE CORP.	FLEX HEALTH BENEFITS	\$	6,085.03
999.1128.000	TOTAL ADMINISTRATIVE SERVICE CORP.	FLEX HEALTH BENEFITS	\$	983.44
999.1129.000	TOTAL ADMINISTRATIVE SERVICE CORP.	FLEX DEP CARE BENEFITS	\$	1,454.57
999.1129.000	TOTAL ADMINISTRATIVE SERVICE CORP.	FLEX DEP CARE BENEFITS	\$	625.00
184.5030.5242.000	Town Apartments Corporation	Rent Assistance	\$	273.00
184.5030.5242.000	Town Apartments Corporation	Rent Assistance	\$	419.00
999.1102.000	TREASURER STATE OF IOWA	Bi-Weekly Payroll SIT	\$	9,919.43
999.1102.000	TREASURER STATE OF IOWA	Bi-Weekly Payroll SIT	\$	5,128.43
690.8050.5210.000	Trending Media Inc	Transit advertising	\$	115.00
690.8050.5210.000	Trending Media Inc	Transit advertising-KFJB	\$	48.00
001.4030.5611.000	Tri State Lock Service	padlocks	\$	90.00
001.4065.5342.000	Tri State Lock Service	Coliseum re-key door	\$	114.00
610.8015.5600.000	Trojan Technologies Corp - USA	UV replacement parts	\$	6,418.44
184.5030.5242.000	TTLCoop Housing	Rent Assistance	\$	751.00
184.5030.5242.000	TTLCoop Housing	Rent Assistance	\$	710.00
184.5030.5242.000	TTLCoop Housing	Rent Assistance	\$	248.00
001.1075.5347.000	Tyler Technologies Inc	EnerGov 4/1/26-3/31/27	\$	6,160.75
110.2010.5600.000	Vajgrt, Roger	Propane100lb tank	\$	183.18
184.5030.5242.000	Walker, Angela	Rent Assistance	\$	308.00
184.5030.5246.000	Wallace, Yianna	Rent Assistance	\$	41.00
184.5030.5246.000	Weatherly, Cassandra	Rent Assistance	\$	31.00
615.8015.5342.000	Wendler Inc	WPC24001 WPCP Sludge Thick Cons 4/1/26-4/30/26	\$	25,098.75
184.5030.5242.000	White, Amalia	Rent Assistance	\$	726.00
184.5030.5246.000	Wirth, Tammy	Rent Assistance	\$	28.00
610.8015.5980.000	Wise, Elizabeth	Sewer refund filled pool	\$	35.12
001.1010.5472.000	Wonderlin, Steve	ILEA weeks 14-16	\$	178.50
001.1099.5482.000	WoodRiver Energy LLC	Police & Fire Bldg 11672	\$	4,215.10
001.1099.5482.000	WoodRiver Energy LLC	Police & Fire Bldg 11672	\$	2,649.60
001.4010.5482.000	WoodRiver Energy LLC	Library gas #7078	\$	530.61
001.4045.5482.000	WoodRiver Energy LLC	SWIMMING POOL 7077	\$	40.00
001.4045.5482.000	WoodRiver Energy LLC	SWIMMING POOL 7077	\$	40.00
184.5030.5242.000	Worsfold Farm LLC	Rent Assistance	\$	370.00
001.4045.5410.000	WW GRAINGER	Aquatic Center water line repairs	\$	13.26
001.4045.5410.000	WW GRAINGER	Aquatic Center shower valve assembly	\$	236.50
001.4045.5410.000	WW GRAINGER	Aquatic Center shower valve assembly	\$	236.50
364.4030.5410.000	WW GRAINGER	Linn Creek trail head shrink tubing	\$	81.86
610.8015.5344.000	Xerox Corp	WPCP April '26 Xerox and copies	\$	25.72
001.4030.5342.000	Ziegler Inc	PWB generator service call	\$	367.70
110.2010.5342.000	Ziegler Inc	PWB generator service call	\$	428.99
690.8050.5342.000	Ziegler Inc	PWB generator service call	\$	428.99
TOTAL			\$	1,652,931.01



**MARSHALLTOWN
MORE THAN EVER**

**Mike Ladehoff, Mayor
Carol Webb, City Administrator
24 North Center Street
Marshalltown, IA 50158
PH 641.754.5701 • FX 641.754.5717**

To: Mayor and City Council
From: Alicia Hunter, City Clerk
Meeting Date: May 11, 2026
Re: Approve Retail Tobacco Permit Renewals for FY2026-2027 - Har Shiva Inc at 613 North 3rd Avenue

Strategic Plan Objective:

Recommended:

Budget Impact:

Description/Background:

Attachments:

None



**MARSHALLTOWN
MORE THAN EVER**

**Mike Ladehoff, Mayor
Carol Webb, City Administrator
24 North Center Street
Marshalltown, IA 50158
PH 641.754.5701 • FX 641.754.5717**

To: Mayor and City Council
From:
Meeting Date: May 11, 2026
Re: Appoint Monte Eaton to the Building Board of Appeals, term ending 12/31/30

Strategic Plan Objective:

Recommended:

Budget Impact:

Description/Background:

Attachments:

None



**MARSHALLTOWN
MORE THAN EVER**

**Mike Ladehoff, Mayor
Carol Webb, City Administrator
24 North Center Street
Marshalltown, IA 50158
PH 641.754.5701 • FX 641.754.5717**

To: Mayor and City Council
From:
Meeting Date: May 11, 2026
Re: Receipt of April 2026 Building and Trade Permit Report

Strategic Plan Objective:

Recommended:

Budget Impact:

Description/Background:

Attachments:

1. April 2026 Building & Trade Permit Report

BUILDING REPORT FOR THE MONTH OF APRIL 2026

MARSHALLTOWN
IOWA

PERMIT NUMBER	OWNER OF IMPROVEMENT	LOCATION OF IMPROVEMENT	TYPE OF IMPROVEMENT	NEW DWELLING	ALTER DWELLING	MINOR RES. BUILDING	COMMERCIAL IMPROVEMENT	FEE		
BLDR-012028-2026	NEW ERA DEVELOPMENT LLC	807 WOODSIDE DR	ACCESSORY STRUCTURE - SHED ALTERATION -			\$ 4,200.00		\$ 103.00		
BLDR-012051-2026	LAUREN K & MILES F MANCIERI	1916 KNOLLWOOD DR	ADDITION AND PATIO ROOF		\$ 13,709.95			\$ 229.00		
DEMO-012052-2026	MARSHALLTOWN COMMUNITY SCHOOL DISTRICT	12 N 14TH ST	DEMOLITION - SINGLE FAMILY DETACHED					\$ 50.00		
DEMO-012053-2026	MARSHALLTOWN COMMUNITY SCHOOL DISTRICT	107 S 12TH ST	DEMOLITION - SINGLE FAMILY DETACHED					\$ 50.00		
DEMO-012054-2026	STEPHEN R SZABO	1918 S 5TH AVE	DEMOLITION - SINGLE FAMILY DETACHED					EXEMPT - CITY ORDERED		
BLDR-012039-2026	RAMIRO RODRIQUEZ & RAQUEL MAGANA MAGANA	312 NEWCASTLE RD	ACCESSORY STRUCTURE - SHED ALTERATION -			\$ 6,860.00		\$ 131.00		
BLDC-012024-2026	SHOPS AT MARSHALLTOWN LLC	2500 S CENTER ST	REMODEL OF SHOE SENSATION				\$ 220,729.58	\$ 1,709.00		
BLDR-012016-2026	TOP NOTCH TREE SERVICE INC	206 S 17TH AVE	NEW CONSTRUCTION - FOUNDATION ONLY, HOUSE MOVE	\$ 28,443.20				\$ 881.00		
BLDR-012015-2026	GABRIELA & FERNANDO SAMUEL GARCIA	509 ARLINGTON DR	ACCESSORY STRUCTURE - DETACHED GARAGE			\$ 31,500.00		\$ 453.00		
BLDR-012000-2026	ARACELY E CANTU GONZALEZ & MAGDALENO GUTIERREZ	506 W INGLEDUE ST	ALTERATION - ADDITION		\$ 2,874.00			\$ 75.00		
BLDR-012048-206	SCOTT W ANDERSON	1607 ELDER RD	ACCESSORY STRUCTURE - DETACHED GARAGE			\$ 26,880.00		\$ 403.00		
BLDC-011953-2026	DENNIS L OLSON	1305 JACKSON ST	NEW CONSTRUCTION - INDUSTRIAL SHOP				\$ 228,936.96	\$ 1,879.00		
DEMO-012074-2026	MICHAEL NEEDHAM	612 S 6TH ST	DEMOLITION - DETACHED GARAGE					\$ 50.00		
BLDC-012038-2026	SIMMS COMPANY LLC	26 E MAIN ST	ALTERATION - TENANT IMPROVEMENT (BIG ACAI)				\$ 29,662.50	\$ 433.00		
BLDR-012014-2026	CWF OF MARSHALLTOWN LLC	511 W CHURCH ST	ALTERATION - SINGLE FAMILY DETACHED		\$ 65,941.20			\$ 745.00		
BLDC-010970-2025	MARSHALLTOWN CHRISTIAN SCHOOL	1408 S 7TH AVE	REMODEL ACCESSORY STRUCTURE - SHED				\$ 4,900.00	\$ 103.00		
DEMO-011933-2026	BLANCA ESTHELA	1007 SWAYZE ST	DEMOLITION - DETACHED GARAGE					\$ 50.00		
DEMO-011934-2026	BLANCA ESTHELA	418 N 11TH AVE	DEMOLITION - SINGLE FAMILY DETACHED					\$ 50.00		
BLDC-012093-2026	SALT CREEK WIND LLC	1209 INDUSTRIAL BLVD	ALTERATION - INTERIOR REMODEL				\$ 126,226.50	\$ 1,145.00		
BLDR-012104-2026	LEAH R & DAVID G MATTOX	1906 W OLIVE ST	ACCESSORY STRUCTURE - DETACHED GARAGE			\$ 36,400.00		\$ 503.00		
TOTALS:				\$28,443.20	\$82,525.15	\$105,840.00	\$610,455.54	\$9,042.00		
TOTAL IMPROVEMENT AMOUNT:				\$827,263.89						
				Units	Permits	Permits	Permits	Permits	Demo Permits	
*Work started without a permit - fee is doubled				# OF PERMITS:	1	1	3	5	5	6

April 2026 Building Permit Volume

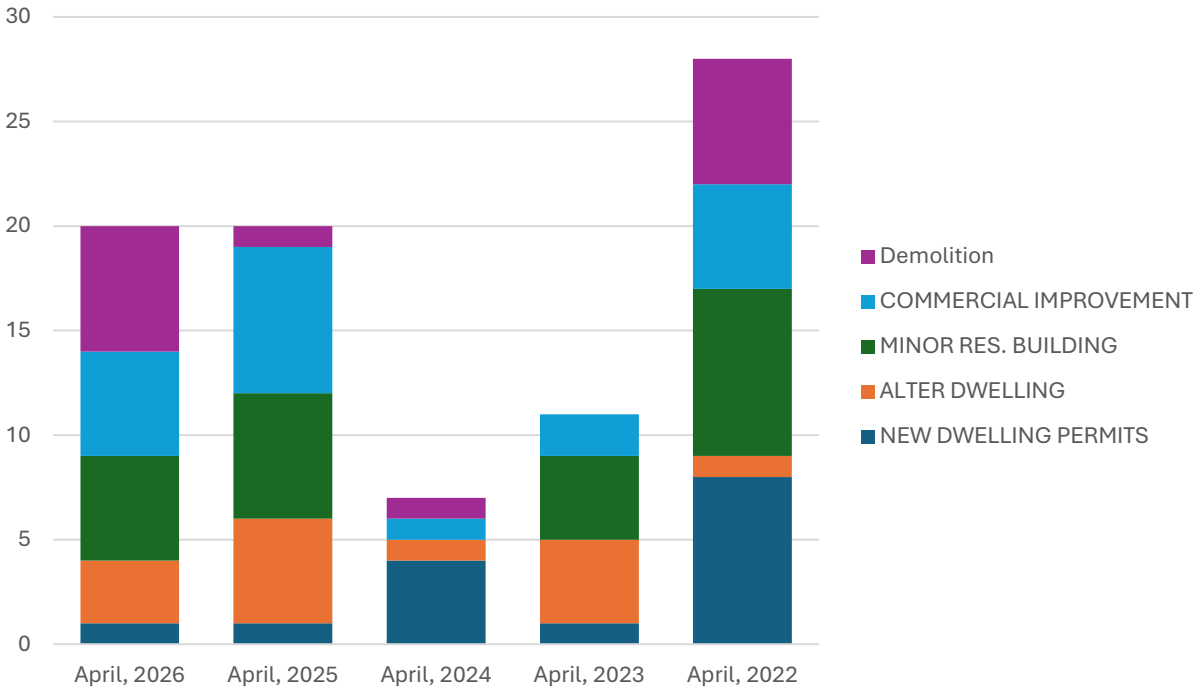

April 2026 Building Permit Valuation

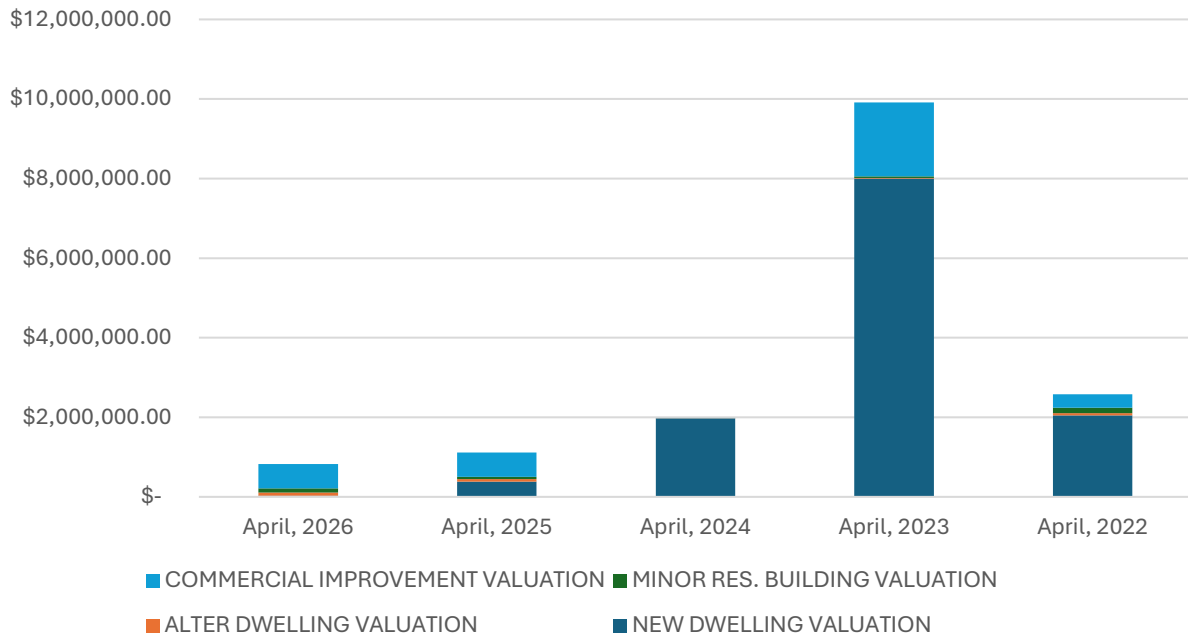

TRADE PERMIT REPORT FOR THE MONTH OF APRIL 2026

MARSHALLTOWN
IOWA

PERMIT NUMBER	LOCATION OF IMPROVEMENT	RESIDENTIAL/COMMERCIAL	PERMIT TYPE (ELEC., PLUMB., MECH. OR SOLAR)	VALUATION	FEE
PLMR-012005-2026	511 W CHURCH ST	RESIDENTIAL	PLUMBING		\$ 85.00
ELEC-012023-2026	1310 IOWA AVE W	COMMERCIAL	ELECTRICAL	\$ 10,000.00	\$ 95.00
ELER-011834-2026	924 S 10TH AVE	RESIDENTIAL	ELECTRICAL		\$ 85.00
MECH-011967-2026	507 IOWA AVE W	COMMERCIAL	MECHANICAL	\$ 16,000.00	\$ 125.00
MECH-011982-2026	2116 EDGEBROOK DR	RESIDENTIAL	MECHANICAL		\$ 62.00
ELEC-012019-2026	2502 S 2ND ST	COMMERCIAL	SOLAR	\$ 36,175.00	\$ 230.00
ELER-012035-2026	308 E SOUTHRIDGE RD	RESIDENTIAL	SOLAR		\$ 95.00
ELER-012036-2026	1701 S CENTER ST	RESIDENTIAL	SOLAR		\$ 95.00
ELER-012040-2026	511 W CHURCH ST	RESIDENTIAL	ELECTRICAL		\$ 85.00
MECH-012004-2026	1215 FREMONT ST	RESIDENTIAL	MECHANICAL		\$ 62.00
MECH-011949-2026	2500 S CENTER ST	COMMERCIAL	MECHANICAL	\$ 242,600.00	\$ 1,258.00
ELER-011850-2026	1207 E BOONE ST	RESIDENTIAL	ELECTRICAL		\$ 85.00
ELER-012021-2026	2 S 6TH ST	RESIDENTIAL	ELECTRICAL		\$ 85.00
ELER-012032-2026	1001 E SOUTHRIDGE ST	RESIDENTIAL	ELECTRICAL		\$ 85.00
ELER-012033-2026	606 ANN RUTLEDGE RD	RESIDENTIAL	ELECTRICAL		\$ 85.00
ELER-012034-2026	6 N 5TH ST	RESIDENTIAL	ELECTRICAL		\$ 85.00
ELER-012057-2026	603 CREEKSIDE LN UNIT V	RESIDENTIAL	ELECTRICAL		\$ 85.00
ELER-012058-2026	603 CREEKSIDE LN UNIT W	RESIDENTIAL	ELECTRICAL		\$ 85.00
ELER-012059-2026	603 CREEKSIDE LN UNIT X	RESIDENTIAL	ELECTRICAL		\$ 85.00
ELER-012061-2026	306 S 2ND AVE	RESIDENTIAL	ELECTRICAL		\$ 85.00
ELER-012065-2026	1701 S 5TH ST	RESIDENTIAL	SOLAR		\$ 95.00
ELER-012070-2026	208 W GRANT ST	RESIDENTIAL	SOLAR		\$ 95.00
ELER-012071-2026	1013 S 11TH AVE	RESIDENTIAL	SOLAR		\$ 95.00
ELER-012077-2026	1407 S 2ND ST	RESIDENTIAL	SOLAR		\$ 95.00
ELER-012079-2026	3 W OLIVE ST	RESIDENTIAL	SOLAR		\$ 95.00
PLMR-012049-2026	205 HELM ST	RESIDENTIAL	PLUMBING		\$ 62.00
ELER-012085-2026	406 SUNSET LN	RESIDENTIAL	SOLAR		\$ 95.00
ELER-012094-2026	306 SUMMIT ST	RESIDENTIAL	ELECTRICAL		\$ 62.00
ELEC-011863-2026	105 WASHINGTON ST	COMMERCIAL	ELECTRICAL	\$ 450.00	\$ 50.00
ELER-011872-2026	111 W STATE ST	RESIDENTIAL	ELECTRICAL		\$ 62.00
ELEC-012088-2026	20 E MAIN ST	COMMERCIAL	ELECTRICAL	\$ 18,000.00	\$ 135.00
PLMR-011896-2026	2010 CATALINA PL	RESIDENTIAL	PLUMBING		\$ 85.00
PLMR-011951-2026	408 N 3RD ST	RESIDENTIAL	PLUMBING		\$ 62.00
MECH-012007-2026	513 S 4TH ST	RESIDENTIAL	MECHANICAL		\$ 62.00
MECH-012056-2026	407 N 3RD ST	RESIDENTIAL	MECHANICAL		\$ 62.00
ELER-011910-2026	1706 S 7TH AVE	RESIDENTIAL	ELECTRICAL		\$ 85.00
ELER-012050-2026	110 N 2ND AVE	COMMERCIAL	ELECTRICAL	\$ 5,000.00	\$ 70.00
ELER-012083-2026	705 W MAIN ST	RESIDENTIAL	ELECTRICAL		\$ 85.00
PLMR-012084-2026	705 W MAIN ST	RESIDENTIAL	PLUMBING		\$ 85.00
ELER-012086-2026	1704 S 6TH ST	RESIDENTIAL	ELECTRICAL		\$ 85.00
ELER-012087-2026	406 FREMONT ST	RESIDENTIAL	ELECTRICAL		\$ 85.00
ELER-012113-2026	1314 LARKFIELD CT	RESIDENTIAL	SOLAR		\$ 95.00
ELER-012128-2026	504 W HIGH ST	RESIDENTIAL	ELECTRICAL		\$ 85.00
ELER-012114-2026	413 N 15TH ST	RESIDENTIAL	SOLAR		\$ 95.00

	Residential Permits	Residential Value	Residential Fees	Commercial Permits	Commercial Value	Commercial Fees	Total Fees
Electrical	18	\$ -	\$ 1,484.00	4	\$ 33,450.00	\$ 350.00	\$ 1,896.00
Plumbing	5	\$ -	\$ 379.00	-	\$ -	\$ -	\$ 379.00
Mechanical	4	\$ -	\$ 248.00	2	\$ 258,600.00	\$ 1,383.00	\$ 1,631.00
Solar	10	\$ -	\$ 950.00	1	\$ 36,175.00	\$ 230.00	\$ 1,180.00
TOTALS	37	\$ -	\$ 3,061.00	7	\$ 328,225.00	\$ 1,963.00	\$ 5,086.00

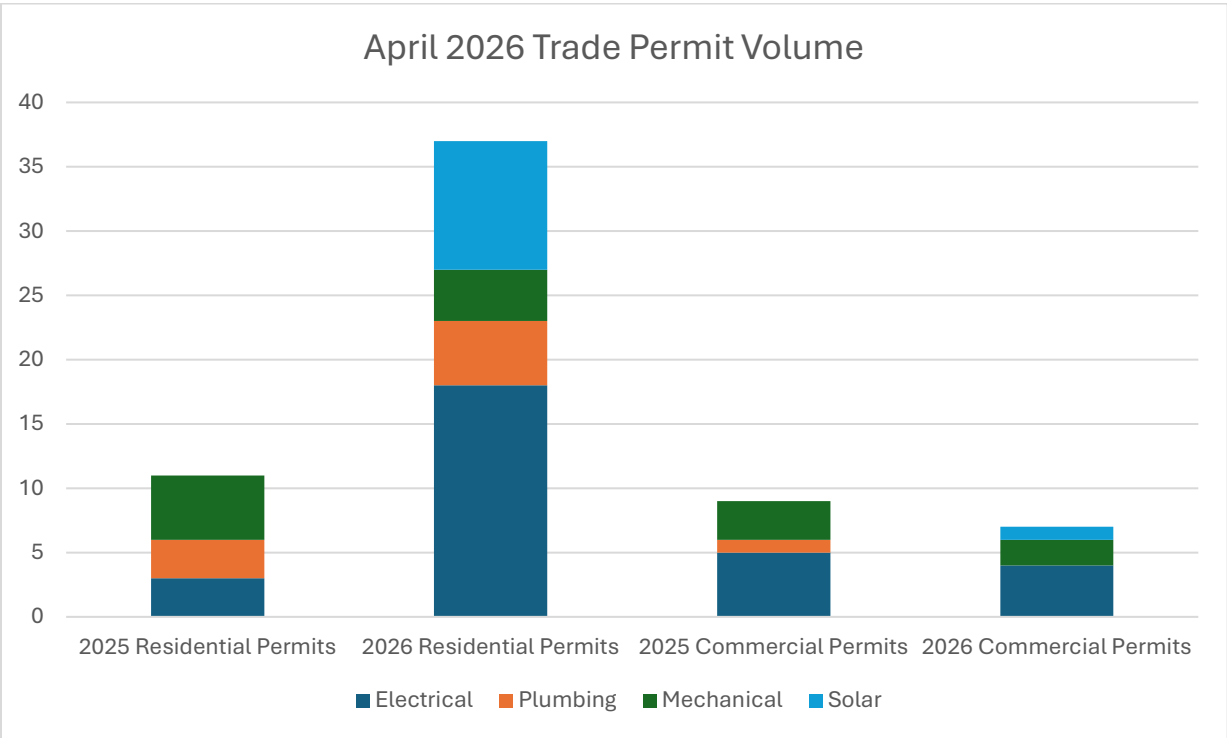
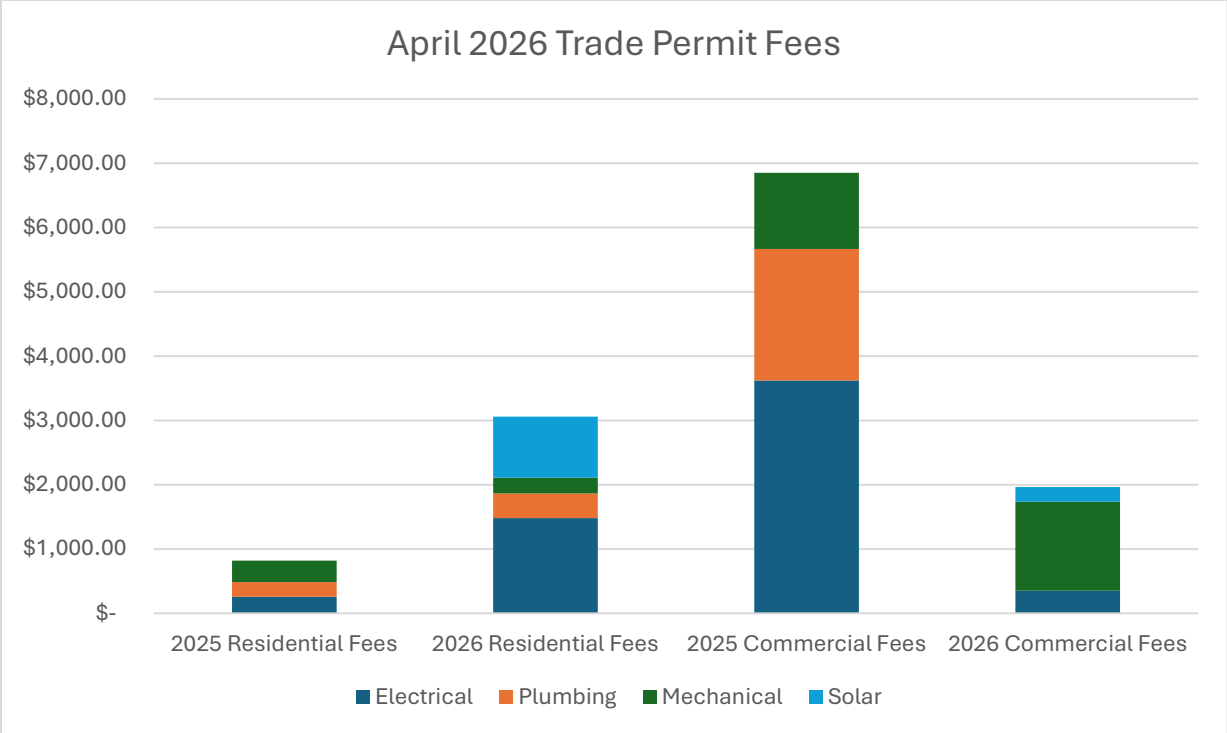



**MARSHALLTOWN
MORE THAN EVER**

**Mike Ladehoff, Mayor
Carol Webb, City Administrator
24 North Center Street
Marshalltown, IA 50158
PH 641.754.5701 • FX 641.754.5717**

To: Mayor and City Council
From: Diana Steiner, Finance Director
Meeting Date: May 11, 2026
Re: Approve March 2026 Financial Statements

Strategic Plan Objective:

N/A

Recommended:

Staff recommends approving the March 2026 monthly financial statements

Budget Impact:

N/A

Description/Background:

The Finance Department has prepared and reconciled the March 2026 financial statements for your review. The budgeted amounts shown are based on the FY26 adopted budget that was approved in April 2025. The budget amendment that Council approved at the April 27 meeting will be reflected in the April 2026 financial statements.

The attached reports include the following:

- Fund Balance Report, which includes the beginning balance at 6/30/25, the year-to-date revenues and expenses for 9 months and the ending fund cash balance at 3/31/26.
- Cash & Investments Report, which includes current balances and interest rates for all city investments.
- Monthly Budget Report, which reflects monthly and year-to-date revenues and expenses by each fund and then in summary. If the YTD Activity amount is less than the YTD Budget amount, it will show as unfavorable for revenues and favorable for expenses.

Items of interest this month:

- \$745,337 was paid for our annual property and liability insurance premiums. Of that, \$471,138 was allocated to the General Fund.

- \$110,490 was spent for the library interior remodel which is being funded by the Friends of the Library.
- \$385,710 was received for property taxes and TIF.

The quarterly transfers were completed including net transfers into the general fund of \$1,446,335.62. For a detail of all year-to-date transfers, see separate Council agenda item

Attachments:

1. March 2026 Financial Statements

MARSHALLTOWN

IOWA

FUND BALANCE REPORT AS OF 3/31/26

Fund	Beginning Balance	Total Revenues	Total Expenses	Ending Balance
001 - GENERAL FUND	\$ 3,687,037.61	\$ 12,763,710.00	\$ 14,996,829.08	\$ 1,453,918.53
010 - CASH FLOW RESERVE FUND	\$ 3,582,377.04	\$ 103,536.58	\$ -	\$ 3,685,913.62
011 - INSURANCE DEDUCTIBLE RESERVE FUND	\$ 262,153.76	\$ 108,003.81	\$ -	\$ 370,157.57
030 - CAPITAL RESERVE	\$ -	\$ 613,985.99	\$ 613,985.99	\$ -
031 - CAPITAL RSRV-BLDG MAINT	\$ 225,445.42	\$ 5,954.56	\$ 25,080.27	\$ 206,319.71
032 - CIP LARGE VEHICLE/EQUIPMENT	\$ 223,209.00	\$ -	\$ -	\$ 223,209.00
110 - ROAD USE TAX	\$ 12,070,509.71	\$ 3,261,125.24	\$ 2,276,363.23	\$ 13,055,271.72
111 - ROAD USE TAX INSURANCE RESERVE	\$ 78,411.35	\$ 27,373.00	\$ -	\$ 105,784.35
112 - EMPLOYEE BENEFITS FUND	\$ 3,148,567.55	\$ 1,700,031.17	\$ 2,497,438.89	\$ 2,351,159.83
117 - POLICE/FIRE RETIREMENT	\$ 599,694.98	\$ 700,994.15	\$ 976,689.20	\$ 323,999.93
119 - EMERGENCY FUND	\$ -	\$ 0.70	\$ 0.70	\$ -
121 - LOCAL OPTION SALES TAX	\$ 4,914,894.35	\$ 3,504,509.20	\$ 3,022,561.61	\$ 5,396,841.94
125 - TAX INCREMENT FINANCING	\$ 667,980.78	\$ 827,184.08	\$ 777,158.16	\$ 718,006.70
126 - TIF-LMI	\$ 8,887.42	\$ 296.13	\$ -	\$ 9,183.55
130 - CITY TORT LIABILITY	\$ 65,616.88	\$ 137,984.85	\$ 97,121.36	\$ 106,480.37
132 - GRANTS-STATE/LOCAL AGENCIES	\$ 4,980.86	\$ 103.63	\$ -	\$ 5,084.49
133 - UNDESIGNATED FEDERAL GRANTS	\$ (6,761.00)	\$ 346,459.63	\$ 340,142.63	\$ (444.00)
139 - PLEASANT HILL POOL FOUNDATION	\$ -	\$ 40,000.00	\$ 9,877.46	\$ 30,122.54
140 - PARK & REC DONATION FUND	\$ (129,286.78)	\$ 436,691.83	\$ 38,165.53	\$ 269,239.52
142 - SOFTBALL ASSOCIATION FUND	\$ (15,021.02)	\$ 37,571.06	\$ 27,495.17	\$ (4,945.13)
144 - LIVE HEALTHY IOWA	\$ 10,258.36	\$ 296.48	\$ -	\$ 10,554.84
145 - TORNADO GENERAL	\$ 40,000.00	\$ -	\$ -	\$ 40,000.00
149 - FEMA - WINDS	\$ 345,665.10	\$ 34,308.17	\$ -	\$ 379,973.27
150 - LOCAL PD GRANTS	\$ (5,091.86)	\$ 48,057.75	\$ 48,212.76	\$ (5,246.87)
151 - DEPT OF JUSTICE GRANTS	\$ -	\$ 1,630.68	\$ 4,759.68	\$ (3,129.00)
152 - POLICE UNDESIGNATED GRANTS	\$ (12,706.29)	\$ 80,803.27	\$ 83,740.70	\$ (15,643.72)
153 - POLICE DEPT DONATION FUND	\$ 88,661.56	\$ 8,669.56	\$ 9,524.00	\$ 87,807.12
154 - AUTOMATED TRAFFIC ENFORCEMENT	\$ 177,943.37	\$ 166,688.24	\$ 260,062.21	\$ 84,569.40
156 - FIRE DEPT DONATION FUND	\$ 51,165.68	\$ 2,229.10	\$ 5,076.08	\$ 48,318.70
160 - ECONOMIC DEVELOPMENT GIFT	\$ 60,217.74	\$ 1,162.37	\$ 20,000.00	\$ 41,380.11
161 - SURETY DEPOSITS/SUBDIVIDER	\$ 12,563.02	\$ 363.09	\$ -	\$ 12,926.11
170 - LIBRARY DONATION FUND	\$ 158,487.86	\$ 475,146.29	\$ 343,443.79	\$ 290,190.36
177 - SEIZED ASSETS (POLICE)	\$ 15,950.01	\$ 5,938.02	\$ 1,101.00	\$ 20,787.03
181 - #7 HUD LEAD GRANT	\$ (319,687.39)	\$ 1,173,828.33	\$ 1,084,495.21	\$ (230,354.27)
184 - VOUCHERS - 002, 003	\$ 366,360.74	\$ 1,140,399.06	\$ 1,092,938.31	\$ 413,821.49
189 - #6 HUD LEAD GRANT/NOW STATE FUNDS ONLY	\$ 165,416.60	\$ 5,430.51	\$ 9,982.00	\$ 160,865.11
200 - GO BONDS DEBT FUND	\$ 180,550.86	\$ 4,105,444.39	\$ 738,183.75	\$ 3,547,811.50
300 - CIP COLLECTION FUND	\$ 732,895.95	\$ 449,551.76	\$ 600,979.96	\$ 581,467.75
312 - AIRPORT PROJECT FUND	\$ 46,003.45	\$ 107,177.91	\$ 165,945.52	\$ (12,764.16)
320 - SPECIAL ASSESSMENT PROJECTS	\$ (14,510.95)	\$ -	\$ -	\$ (14,510.95)
340 - BIKE PATH PROJECT FUND	\$ (12,485.37)	\$ 4,013.54	\$ 184,799.85	\$ (193,271.68)
341 - TREES FOREVER PROJECT	\$ 12,681.09	\$ 6,868.34	\$ 2,415.81	\$ 17,133.62
355 - Dangerous & Dilapidated (included GO bonds)	\$ 212,814.78	\$ 41,111.96	\$ 230,928.83	\$ 22,997.91
362 - 2020 GO BONDS	\$ -	\$ 47,505.66	\$ 47,505.66	\$ -
363 - 2021 GO BONDS	\$ 4,918,858.85	\$ 355,493.17	\$ 3,961,106.47	\$ 1,313,245.55
364 - 2022 GO BONDS	\$ 6,777,883.17	\$ 4,527,893.30	\$ 7,572,957.87	\$ 3,732,818.60
365 - 2023 GO BONDS	\$ 10,489,073.68	\$ 303,192.39	\$ (9,568.51)	\$ 10,801,834.58
389 - AMERICAN RESCUE PLAN	\$ 258,188.48	\$ -	\$ 88,181.84	\$ 170,006.64
610 - WATER POLLUTION CONTROL	\$ -	\$ 3,459,922.75	\$ 3,459,922.75	\$ -
611 - WPCP REVENUE	\$ 26,782,039.10	\$ 6,931,955.41	\$ 4,426,395.27	\$ 29,287,599.24
614 - WPCP CAPITAL IMPROVEMENT RSRV	\$ 1,227,771.41	\$ 35,484.61	\$ -	\$ 1,263,256.02
615 - WPCP PLANT & IMPROVEMENTS	\$ (5,000.00)	\$ 869,831.41	\$ 869,831.41	\$ (5,000.00)
617 - SANITARY SEWER NEW CONSTRUCTN	\$ 197,038.85	\$ 432.00	\$ -	\$ 197,470.85
618 - WPCP INSURANCE RESERVE (WAS TORNADO)	\$ 208,200.44	\$ 106,444.47	\$ -	\$ 314,644.91
690 - TRANSIT OPERATING	\$ 1,523,561.13	\$ 1,068,795.51	\$ 822,558.74	\$ 1,769,797.90
691 - TRANSIT INSURANCE RESERVE	\$ 26,361.23	\$ 761.88	\$ -	\$ 27,123.11
740 - STORM SEWER UTILITY	\$ 2,837,092.96	\$ 1,235,497.64	\$ 738,767.11	\$ 3,333,823.49
750 - COMPOSTING FACILITY	\$ 229,729.59	\$ 75,902.51	\$ 25,691.91	\$ 279,940.19
760 - P&R CONCESSIONS ENTERPRISE	\$ 2,036.37	\$ 31,729.00	\$ 44,771.42	\$ (11,006.05)
881 - OCCUPATIONAL INSURANCE ESCROW	\$ 317,839.22	\$ 144,153.60	\$ 341,534.56	\$ 120,458.26
884 - GROUP HEALTH INSURANCE ESCROW	\$ 826,474.93	\$ 3,253,326.70	\$ 2,756,936.31	\$ 1,322,865.32
886 - WORKMAN'S COMP DEDUCTIBLE FUND	\$ 37,706.35	\$ 1,088.95	\$ 87.26	\$ 38,708.04
913 - 911 COMMISION	\$ (7,353.65)	\$ 1,182,176.14	\$ 1,315,431.68	\$ (140,609.19)
TOTALS	\$ 88,349,354.33	\$ 56,106,221.53	\$ 57,047,610.49	\$ 87,407,965.37

MARSHALLTOWN

I O W A

CASH AND INVESTMENTS
AS OF 3/31/26

Account	Name	Ending Balance	Interest Rate
BalObject: 0110 - P&R Deposits			
<u>999.0110.100</u>	First Interstate Bank P&R Deposits	<u>150,885.00</u>	2.53
	Total BalObject: 0110 - P&R Deposits :	150,885.00	
BalObject: 0111 - Operating			
<u>999.0111.100</u>	First Interstate Bank Operating	<u>1,019,619.14</u>	2.53
	Total BalObject: 0111 - Operating:	1,019,619.14	
BalObject: 0113 - Payroll			
<u>999.0113.100</u>	First Interstate Bank Payroll	<u>450,000.00</u>	2.53
	Total BalObject: 0113 - Payroll:	450,000.00	
BalObject: 0115 - HUD Admin			
<u>999.0115.100</u>	First Interstate Bank HUD Admin	<u>365,154.03</u>	2.53
	Total BalObject: 0115 - HUD Admin:	365,154.03	
BalObject: 0116 - HUD HAP			
<u>999.0116.100</u>	First Interstate Bank HUD HAP	<u>59,814.63</u>	2.53
	Total BalObject: 0116 - HUD HAP:	59,814.63	
BalObject: 0117 - Police			
<u>999.0117.100</u>	First Interstate Bank Police	<u>20,787.03</u>	2.53
	Total BalObject: 0117 - Police:	20,787.03	
BalObject: 0117 - ACH			
<u>999.0118.100</u>	First Interstate Bank ACH	<u>1,000.00</u>	2.53
	Total BalObject: 0118 - ACH	1,000.00	
BalObject: 0120 - PETTY CASH			
<u>001.0120.000</u>	PETTY CASH - RECORDS	100.00	0.00
<u>144.0120.000</u>	PETTY CASH-TRACK MEET	-	0.00
<u>750.0120.000</u>	PETTY CASH	500.00	0.00
<u>760.0120.000</u>	PETTY CASH	-	0.00
	Total BalObject: 0120 - PETTY CASH:	600.00	
BalObject: 0122 - PETTY CASH-CITY CLERK			
<u>001.0122.000</u>	PETTY CASH-CITY CLERK	<u>200.00</u>	0.00
	Total BalObject: 0122 - PETTY CASH-CITY CLERK:	200.00	
Page 1:2			
BalObject: 0123 - PETTY CASH-LIBRARY			
<u>001.0123.000</u>	PETTY CASH-LIBRARY	<u>100.00</u>	0.00
	Total BalObject: 0123 - PETTY CASH-LIBRARY:	100.00	
BalObject: 0124 - PETTY CASH-LIBRARY			
<u>001.0124.000</u>	PETTY CASH-LIBRARY	<u>200.00</u>	0.00
	Total BalObject: 0124 - PETTY CASH-LIBRARY:	200.00	
BalObject: 0125 - PETTY CASH-PARK			
<u>001.0125.000</u>	PETTY CASH-PARK	<u>225.00</u>	0.00
	Total BalObject: 0125 - PETTY CASH-PARK:	225.00	
BalObject: 0126 - PETTY CASH-COLISEUM CONCESSIONS			
<u>001.0126.000</u>	PETTY CASH-COLISEUM CONCESSIONS	<u>300.00</u>	0.00
	Total BalObject: 0125 - PETTY CASH-COLISEUM:	300.00	
BalObject: 0130 - CASH HELD BY INSUR ADMIN			
<u>885.0130.000</u>	CASH HELD BY INSUR ADM	<u>1.00</u>	0.00
	Total BalObject: 0130 - CASH HELD BY INSUR ADM	1.00	
BalObject: 0215 - IPAIT MONEY MARKET			
<u>999.0215.000</u>	IPAIT MONEY MARKET	<u>14,641,223.11</u>	3.435
	Total BalObject: 0215 - IPAIT MONEY MARKET:	14,641,223.11	
BalObject: 0216 - FIRST INTERSTATE BANK MM			
<u>999.0216.000</u>	First Interstate Bank MM	<u>6,501,983.61</u>	2.53
	Total BalObject: 0216 - FIRST INTERSTATE BANK MM	6,501,983.61	
BalObject: 0243 - GNB INV			
<u>365.0243.000</u>	GNB CD		
<u>999.0243.000</u>	GNB CD	<u>33,000,000.00</u>	3.53-3.80
	Total BalObject: 0243 - GNB INV	33,000,000.00	
BalObject: 0246 - PINNACLE INV			
<u>365.0246.000</u>	PINNACLE CD		
<u>999.0246.000</u>	PINNACLE CD	<u>24,182,679.46</u>	3.70-4.10
	Total BalObject: 0246 - PINNACLE CD	24,182,679.46	
BalObject: 0248 - Alerus Financial			
<u>999.0248.000</u>	Alerus CD	<u>4,000,000.00</u>	3.75-3.80
	Total BalObject: 0248 - ALERUS CD	4,000,000.00	
BalObject: 0265 - IPAIT CD			
<u>999.0265.000</u>	IPAIT CD	<u>3,000,000.00</u>	3.640
	Total BalObject: 0265 - IPAIT CD	3,000,000.00	
BalObject: 0999 - POOLED CASH			
<u>999.0999.000</u>	POOLED CASH - prepaid work comp and outstanding AP	<u>13,193.36</u>	
	Total BalObject: 0999 - POOLED CASH:	13,193.36	
Page 2:2	TOTAL	<u>87,407,965.37</u>	



Monthly Budget Report - Marshalltown Group Summary

For Fiscal: 2025-2026 Period Ending: 03/31/2026

Account Typ...	March Activity	YTD Budget	YTD Activity	Variance Favorable (Unfavorable)	Total Budget
Fund: 001 - GENERAL FUND					
Revenue	1,918,080.98	15,492,598.74	12,763,710.00	-2,728,888.74	20,657,436.00
Expense	1,962,156.45	15,487,853.58	14,996,829.08	491,024.50	20,657,436.00
Total Fund: 001 - GENERAL FUND:	-44,075.47	4,745.16	-2,233,119.08	-2,237,864.24	0.00
Fund: 010 - CASH FLOW RESERVE FUND					
Revenue	15,676.91	221,332.41	103,536.58	-117,795.83	295,192.00
Total Fund: 010 - CASH FLOW RESERVE FUND:	15,676.91	221,332.41	103,536.58	-117,795.83	295,192.00
Fund: 011 - INSURANCE DEDUCTIBLE RESERVE FUND					
Revenue	101,574.35	74,999.97	108,003.81	33,003.84	100,000.00
Total Fund: 011 - INSURANCE DEDUCTIBLE RESERVE FUND:	101,574.35	74,999.97	108,003.81	33,003.84	100,000.00
Fund: 030 - CAPITAL RESERVE					
Revenue	323,124.09	501,022.44	613,985.99	112,963.55	668,030.00
Expense	323,124.09	500,981.22	613,985.99	-113,004.77	668,030.00
Total Fund: 030 - CAPITAL RESERVE:	0.00	41.22	0.00	-41.22	0.00
Fund: 031 - CAPITAL RSRV-BLDG MAINT					
Revenue	877.52	65,619.99	5,954.56	-59,665.43	87,528.00
Expense	0.00	150,124.41	25,080.27	125,044.14	200,166.00
Total Fund: 031 - CAPITAL RSRV-BLDG MAINT:	877.52	-84,504.42	-19,125.71	65,378.71	-112,638.00
Fund: 032 - CIP LARGE VEHICLE/EQUIPMENT					
Revenue	0.00	78,716.25	0.00	-78,716.25	104,955.00
Expense	0.00	176,625.00	0.00	176,625.00	235,500.00
Total Fund: 032 - CIP LARGE VEHICLE/EQUIPMENT:	0.00	-97,908.75	0.00	97,908.75	-130,545.00
Fund: 110 - ROAD USE TAX					
Revenue	319,263.23	3,492,581.85	3,261,125.24	-231,456.61	4,656,776.00
Expense	373,369.78	4,084,610.04	2,276,363.23	1,808,246.81	5,446,164.00
Total Fund: 110 - ROAD USE TAX:	-54,106.55	-592,028.19	984,762.01	1,576,790.20	-789,388.00
Fund: 111 - ROAD USE TAX INSURANCE RESERVE					
Revenue	25,449.92	20,616.75	27,373.00	6,756.25	27,500.00
Total Fund: 111 - ROAD USE TAX INSURANCE RESERVE:	25,449.92	20,616.75	27,373.00	6,756.25	27,500.00
Fund: 112 - EMPLOYEE BENEFITS FUND					
Revenue	65,325.42	1,913,973.66	1,700,031.17	-213,942.49	2,551,965.00
Expense	815,821.59	2,926,376.73	2,497,438.89	428,937.84	3,903,397.00
Total Fund: 112 - EMPLOYEE BENEFITS FUND:	-750,496.17	-1,012,403.07	-797,407.72	214,995.35	-1,351,432.00

Monthly Budget Report - Marshalltown

For Fiscal: 2025-2026 Period Ending: 03/31/2026

Account Typ...	March Activity	YTD Budget	YTD Activity	Variance Favorable (Unfavorable)	Total Budget
Fund: 117 - POLICE/FIRE RETIREMENT					
Revenue	24,854.35	1,069,659.63	700,994.15	-368,665.48	1,426,213.00
Expense	301,500.75	1,018,746.27	976,689.20	42,057.07	1,358,872.00
Total Fund: 117 - POLICE/FIRE RETIREMENT:	-276,646.40	50,913.36	-275,695.05	-326,608.41	67,341.00
Fund: 119 - EMERGENCY FUND					
Revenue	0.00	0.00	0.70	0.70	0.00
Expense	0.00	0.00	0.70	-0.70	0.00
Total Fund: 119 - EMERGENCY FUND:	0.00	0.00	0.00	0.00	0.00
Fund: 121 - LOCAL OPTION SALES TAX					
Revenue	356,791.39	3,227,017.50	3,504,509.20	277,491.70	4,302,690.00
Expense	951,395.13	4,328,444.70	3,022,561.61	1,305,883.09	5,772,684.00
Total Fund: 121 - LOCAL OPTION SALES TAX:	-594,603.74	-1,101,427.20	481,947.59	1,583,374.79	-1,469,994.00
Fund: 125 - TAX INCREMENT FINANCING					
Revenue	41,685.93	1,044,930.69	827,184.08	-217,746.61	1,393,241.00
Expense	40,000.00	1,472,732.91	777,158.16	695,574.75	1,963,644.00
Total Fund: 125 - TAX INCREMENT FINANCING:	1,685.93	-427,802.22	50,025.92	477,828.14	-570,403.00
Fund: 126 - TIF-LMI					
Revenue	39.06	21,496.14	296.13	-21,200.01	28,673.00
Total Fund: 126 - TIF-LMI:	39.06	21,496.14	296.13	-21,200.01	28,673.00
Fund: 130 - CITY TORT LIABILITY					
Revenue	28,106.40	30,749.94	137,984.85	107,234.91	41,000.00
Expense	-45.00	29,999.97	97,121.36	-67,121.39	40,000.00
Total Fund: 130 - CITY TORT LIABILITY:	28,151.40	749.97	40,863.49	40,113.52	1,000.00
Fund: 132 - GRANTS-STATE/LOCAL AGENCIES					
Revenue	21.63	292,500.00	103.63	-292,396.37	390,000.00
Expense	0.00	449,625.69	0.00	449,625.69	599,501.00
Total Fund: 132 - GRANTS-STATE/LOCAL AGENCIES:	21.63	-157,125.69	103.63	157,229.32	-209,501.00
Fund: 133 - UNDESIGNATED FEDERAL GRANTS					
Revenue	0.00	317,450.16	346,459.63	29,009.47	423,267.00
Expense	444.00	317,432.70	340,142.63	-22,709.93	423,267.00
Total Fund: 133 - UNDESIGNATED FEDERAL GRANTS:	-444.00	17.46	6,317.00	6,299.54	0.00
Fund: 139 - PLEASANT HILL POOL FOUNDATION					
Revenue	0.00	0.00	40,000.00	40,000.00	0.00
Expense	3,273.45	0.00	9,877.46	-9,877.46	0.00
Total Fund: 139 - PLEASANT HILL POOL FOUNDATION:	-3,273.45	0.00	30,122.54	30,122.54	0.00
Fund: 140 - PARK & REC DONATION FUND					
Revenue	3,913.00	313,311.69	436,691.83	123,380.14	417,749.00
Expense	2,640.68	462,523.23	38,165.53	424,357.70	616,698.00
Total Fund: 140 - PARK & REC DONATION FUND:	1,272.32	-149,211.54	398,526.30	547,737.84	-198,949.00

Monthly Budget Report - Marshalltown

For Fiscal: 2025-2026 Period Ending: 03/31/2026

Account Typ...	March Activity	YTD Budget	YTD Activity	Variance Favorable (Unfavorable)	Total Budget
Fund: 141 - MTOWN TENNIS ASSOC					
Revenue	0.00	14.94	0.00	-14.94	20.00
Total Fund: 141 - MTOWN TENNIS ASSOC:	0.00	14.94	0.00	-14.94	20.00
Fund: 142 - SOFTBALL ASSOCIATION FUND					
Revenue	0.00	34,263.45	37,571.06	3,307.61	45,703.00
Expense	415.40	34,255.71	27,495.17	6,760.54	45,703.00
Total Fund: 142 - SOFTBALL ASSOCIATION FUND:	-415.40	7.74	10,075.89	10,068.15	0.00
Fund: 144 - LIVE HEALTHY IOWA					
Revenue	44.89	5,659.47	296.48	-5,362.99	7,546.00
Expense	0.00	5,657.40	0.00	5,657.40	7,544.00
Total Fund: 144 - LIVE HEALTHY IOWA :	44.89	2.07	296.48	294.41	2.00
Fund: 149 - FEMA - WINDS					
Revenue	0.00	0.00	34,308.17	34,308.17	0.00
Total Fund: 149 - FEMA - WINDS:	0.00	0.00	34,308.17	34,308.17	0.00
Fund: 150 - LOCAL PD GRANTS					
Revenue	5,085.86	44,982.00	48,057.75	3,075.75	60,000.00
Expense	5,247.24	44,982.00	48,212.76	-3,230.76	60,000.00
Total Fund: 150 - LOCAL PD GRANTS:	-161.38	0.00	-155.01	-155.01	0.00
Fund: 151 - DEPT OF JUSTICE GRANTS					
Revenue	0.00	15,685.92	1,630.68	-14,055.24	20,923.00
Expense	0.00	15,597.45	4,759.68	10,837.77	20,800.00
Total Fund: 151 - DEPT OF JUSTICE GRANTS:	0.00	88.47	-3,129.00	-3,217.47	123.00
Fund: 152 - POLICE UNDESIGNATED GRANTS					
Revenue	1,923.00	57,755.25	80,803.27	23,048.02	77,007.00
Expense	2,662.08	57,734.46	83,740.70	-26,006.24	77,007.00
Total Fund: 152 - POLICE UNDESIGNATED GRANTS:	-739.08	20.79	-2,937.43	-2,958.22	0.00
Fund: 153 - POLICE DEPT DONATION FUND					
Revenue	573.46	2,399.94	8,669.56	6,269.62	3,200.00
Expense	200.00	10,758.87	9,524.00	1,234.87	14,350.00
Total Fund: 153 - POLICE DEPT DONATION FUND:	373.46	-8,358.93	-854.44	7,504.49	-11,150.00
Fund: 154 - AUTOMATED TRAFFIC ENFORCEMENT					
Revenue	12,847.19	194,999.94	166,688.24	-28,311.70	260,000.00
Expense	12,460.00	279,695.34	260,062.21	19,633.13	373,000.00
Total Fund: 154 - AUTOMATED TRAFFIC ENFORCEMENT:	387.19	-84,695.40	-93,373.97	-8,678.57	-113,000.00
Fund: 156 - FIRE DEPT DONATION FUND					
Revenue	205.51	2,249.91	2,229.10	-20.81	3,000.00
Expense	117.74	18,220.41	5,076.08	13,144.33	24,298.00
Total Fund: 156 - FIRE DEPT DONATION FUND:	87.77	-15,970.50	-2,846.98	13,123.52	-21,298.00

Monthly Budget Report - Marshalltown

For Fiscal: 2025-2026 Period Ending: 03/31/2026

Account Typ...	March Activity	YTD Budget	YTD Activity	Variance Favorable (Unfavorable)	Total Budget
Fund: 160 - ECONOMIC DEVELOPMENT GIFT					
Revenue	176.00	749.97	1,162.37	412.40	1,000.00
Expense	0.00	0.00	20,000.00	-20,000.00	0.00
Total Fund: 160 - ECONOMIC DEVELOPMENT GIFT:	176.00	749.97	-18,837.63	-19,587.60	1,000.00
Fund: 161 - SURETY DEPOSITS/SUBDIVIDER					
Revenue	54.98	138.69	363.09	224.40	185.00
Total Fund: 161 - SURETY DEPOSITS/SUBDIVIDER:	54.98	138.69	363.09	224.40	185.00
Fund: 170 - LIBRARY DONATION FUND					
Revenue	1,434.24	318,356.19	475,146.29	156,790.10	424,475.00
Expense	111,299.65	626,054.67	343,443.79	282,610.88	834,740.00
Total Fund: 170 - LIBRARY DONATION FUND:	-109,865.41	-307,698.48	131,702.50	439,400.98	-410,265.00
Fund: 177 - SEIZED ASSETS (POLICE)					
Revenue	45.42	2,624.04	5,938.02	3,313.98	3,500.00
Expense	0.00	4,498.47	1,101.00	3,397.47	6,000.00
Total Fund: 177 - SEIZED ASSETS (POLICE):	45.42	-1,874.43	4,837.02	6,711.45	-2,500.00
Fund: 181 - #7 HUD LEAD GRANT					
Revenue	183,997.32	1,805,939.55	1,173,828.33	-632,111.22	2,408,883.00
Expense	118,430.15	1,806,479.01	1,084,495.21	721,983.80	2,408,883.00
Total Fund: 181 - #7 HUD LEAD GRANT:	65,567.17	-539.46	89,333.12	89,872.58	0.00
Fund: 184 - VOUCHERS - 002, 003					
Revenue	115,576.06	1,086,322.32	1,140,399.06	54,076.74	1,448,431.00
Expense	107,258.99	1,091,709.72	1,092,938.31	-1,228.59	1,455,690.00
Total Fund: 184 - VOUCHERS - 002, 003:	8,317.07	-5,387.40	47,460.75	52,848.15	-7,259.00
Fund: 189 - #6 HUD LEAD GRANT/NOW STATE FUNDS ONLY					
Revenue	184.19	0.00	5,430.51	5,430.51	0.00
Expense	9,930.00	0.00	9,982.00	-9,982.00	0.00
Total Fund: 189 - #6 HUD LEAD GRANT/NOW STATE FUNDS ONLY:	-9,745.81	0.00	-4,551.49	-4,551.49	0.00
Fund: 200 - GO BONDS DEBT FUND					
Revenue	914,381.59	5,454,728.91	4,105,444.39	-1,349,284.52	7,273,085.00
Expense	0.00	5,484,125.88	738,183.75	4,745,942.13	7,312,168.00
Total Fund: 200 - GO BONDS DEBT FUND:	914,381.59	-29,396.97	3,367,260.64	3,396,657.61	-39,083.00
Fund: 300 - CIP COLLECTION FUND					
Revenue	17,941.11	553,559.04	449,551.76	-104,007.28	738,079.00
Expense	323,088.19	579,738.69	600,979.96	-21,241.27	772,985.00
Total Fund: 300 - CIP COLLECTION FUND:	-305,147.08	-26,179.65	-151,428.20	-125,248.55	-34,906.00
Fund: 311 - RISE STREET GRANTS					
Revenue	0.00	255,764.16	0.00	-255,764.16	341,019.00
Expense	0.00	255,673.08	0.00	255,673.08	341,018.00
Total Fund: 311 - RISE STREET GRANTS:	0.00	91.08	0.00	-91.08	1.00

Account Typ...	March Activity	YTD Budget	YTD Activity	Variance Favorable (Unfavorable)	Total Budget
Fund: 312 - AIRPORT PROJECT FUND					
Revenue	22,370.00	769,874.94	107,177.91	-662,697.03	1,026,500.00
Expense	21,738.33	844,874.91	165,945.52	678,929.39	1,126,500.00
Total Fund: 312 - AIRPORT PROJECT FUND:	631.67	-74,999.97	-58,767.61	16,232.36	-100,000.00
Fund: 340 - BIKE PATH PROJECT FUND					
Revenue	0.00	1,226,250.00	4,013.54	-1,222,236.46	1,635,000.00
Expense	22,647.10	1,226,249.91	184,799.85	1,041,450.06	1,635,000.00
Total Fund: 340 - BIKE PATH PROJECT FUND:	-22,647.10	0.09	-180,786.31	-180,786.40	0.00
Fund: 341 - TREES FOREVER PROJECT					
Revenue	72.87	26,849.88	6,868.34	-19,981.54	35,800.00
Expense	0.00	29,999.97	2,415.81	27,584.16	40,000.00
Total Fund: 341 - TREES FOREVER PROJECT:	72.87	-3,150.09	4,452.53	7,602.62	-4,200.00
Fund: 350 - GO BONDS CAPITAL PROJECTS					
Revenue	0.00	149.94	0.00	-149.94	200.00
Expense	0.00	7,623.72	0.00	7,623.72	10,165.00
Total Fund: 350 - GO BONDS CAPITAL PROJECTS:	0.00	-7,473.78	0.00	7,473.78	-9,965.00
Fund: 355 - Dangerous & Dilapidated (included GO bonds)					
Revenue	97.81	7,879.41	41,111.96	33,232.55	10,510.00
Expense	1,090.00	89,997.93	230,928.83	-140,930.90	120,000.00
Total Fund: 355 - Dangerous & Dilapidated (included GO bonds):	-992.19	-82,118.52	-189,816.87	-107,698.35	-109,490.00
Fund: 362 - 2020 GO BONDS					
Revenue	0.00	0.00	47,505.66	47,505.66	0.00
Expense	0.00	0.00	47,505.66	-47,505.66	0.00
Total Fund: 362 - 2020 GO BONDS:	0.00	0.00	0.00	0.00	0.00
Fund: 363 - 2021 GO BONDS					
Revenue	287,564.42	542,102.13	374,711.93	-167,390.20	722,803.00
Expense	7,375.40	1,934,089.29	3,961,106.47	-2,027,017.18	2,578,786.00
Total Fund: 363 - 2021 GO BONDS:	280,189.02	-1,391,987.16	-3,586,394.54	-2,194,407.38	-1,855,983.00
Fund: 364 - 2022 GO BONDS					
Revenue	46,599.91	8,380,903.95	4,527,893.30	-3,853,010.65	11,174,539.00
Expense	90,014.84	11,143,726.29	7,572,957.87	3,570,768.42	14,858,302.00
Total Fund: 364 - 2022 GO BONDS:	-43,414.93	-2,762,822.34	-3,045,064.57	-282,242.23	-3,683,763.00
Fund: 365 - 2023 GO BONDS					
Revenue	45,860.57	74,999.97	303,110.65	228,110.68	100,000.00
Expense	9,568.51	6,854,334.66	9,568.51	6,844,766.15	9,139,113.00
Total Fund: 365 - 2023 GO BONDS:	36,292.06	-6,779,334.69	293,542.14	7,072,876.83	-9,039,113.00
Fund: 389 - AMERICAN RESCUE PLAN					
Expense	0.00	117,000.00	88,181.84	28,818.16	156,000.00
Total Fund: 389 - AMERICAN RESCUE PLAN:	0.00	117,000.00	88,181.84	28,818.16	156,000.00

Monthly Budget Report - Marshalltown

For Fiscal: 2025-2026 Period Ending: 03/31/2026

Account Typ...	March Activity	YTD Budget	YTD Activity	Variance Favorable (Unfavorable)	Total Budget
Fund: 610 - WATER POLLUTION CONTROL					
Revenue	635,121.78	6,322,059.00	3,459,922.75	-2,862,136.25	8,429,412.00
Expense	635,121.78	6,321,303.99	3,459,922.75	2,861,381.24	8,429,412.00
Total Fund: 610 - WATER POLLUTION CONTROL:	0.00	755.01	0.00	-755.01	0.00
Fund: 611 - WPCP REVENUE					
Revenue	758,858.70	6,219,374.67	6,931,955.41	712,580.74	8,292,500.00
Expense	974,554.46	10,696,028.94	4,426,395.27	6,269,633.67	14,261,412.00
Total Fund: 611 - WPCP REVENUE:	-215,695.76	-4,476,654.27	2,505,560.14	6,982,214.41	-5,968,912.00
Fund: 614 - WPCP CAPITAL IMPROVEMENT RSRV					
Revenue	5,372.87	37,499.94	35,484.61	-2,015.33	50,000.00
Total Fund: 614 - WPCP CAPITAL IMPROVEMENT RSRV:	5,372.87	37,499.94	35,484.61	-2,015.33	50,000.00
Fund: 615 - WPCP PLANT & IMPROVEMENTS					
Revenue	241,079.86	3,474,000.00	869,831.41	-2,604,168.59	4,632,000.00
Expense	55,040.18	3,474,000.00	869,831.41	2,604,168.59	4,632,000.00
Total Fund: 615 - WPCP PLANT & IMPROVEMENTS:	186,039.68	0.00	0.00	0.00	0.00
Fund: 616 - SANITARY SEWER REHAB PROJECT					
Revenue	0.00	824,999.94	0.00	-824,999.94	1,100,000.00
Expense	0.00	824,999.94	0.00	824,999.94	1,100,000.00
Total Fund: 616 - SANITARY SEWER REHAB PROJECT:	0.00	0.00	0.00	0.00	0.00
Fund: 617 - SANITARY SEWER NEW CONSTRUCTN					
Revenue	0.00	5,249.97	432.00	-4,817.97	7,000.00
Total Fund: 617 - SANITARY SEWER NEW CONSTRUCTN:	0.00	5,249.97	432.00	-4,817.97	7,000.00
Fund: 618 - WPCP INSURANCE RESERVE (WAS TORNADO)					
Revenue	101,338.25	74,970.00	106,444.47	31,474.47	100,000.00
Total Fund: 618 - WPCP INSURANCE RESERVE (WAS TORNADO):	101,338.25	74,970.00	106,444.47	31,474.47	100,000.00
Fund: 690 - TRANSIT OPERATING					
Revenue	56,956.91	937,606.86	1,068,795.51	131,188.65	1,250,143.00
Expense	120,871.16	1,036,669.86	822,558.74	214,111.12	1,382,604.00
Total Fund: 690 - TRANSIT OPERATING:	-63,914.25	-99,063.00	246,236.77	345,299.77	-132,461.00
Fund: 691 - TRANSIT INSURANCE RESERVE					
Revenue	115.36	0.00	761.88	761.88	0.00
Total Fund: 691 - TRANSIT INSURANCE RESERVE:	115.36	0.00	761.88	761.88	0.00
Fund: 740 - STORM SEWER UTILITY					
Revenue	233,292.20	1,016,591.94	1,235,497.64	218,905.70	1,355,456.00
Expense	72,570.69	1,255,091.49	738,767.11	516,324.38	1,673,709.00
Total Fund: 740 - STORM SEWER UTILITY:	160,721.51	-238,499.55	496,730.53	735,230.08	-318,253.00
Fund: 750 - COMPOSTING FACILITY					
Revenue	4,654.69	52,124.76	75,902.51	23,777.75	69,500.00
Expense	1,075.78	53,968.41	25,691.91	28,276.50	71,960.00

Monthly Budget Report - Marshalltown

For Fiscal: 2025-2026 Period Ending: 03/31/2026

Account Typ...	March Activity	YTD Budget	YTD Activity	Variance Favorable (Unfavorable)	Total Budget
Total Fund: 750 - COMPOSTING FACILITY:	3,578.91	-1,843.65	50,210.60	52,054.25	-2,460.00
Fund: 760 - P&R CONCESSIONS ENTERPRISE					
Revenue	0.00	36,000.00	31,729.00	-4,271.00	48,000.00
Expense	1,047.68	34,134.03	44,771.42	-10,637.39	45,520.00
Total Fund: 760 - P&R CONCESSIONS ENTERPRISE:	-1,047.68	1,865.97	-13,042.42	-14,908.39	2,480.00
Fund: 881 - OCCUPATIONAL INSURANCE ESCROW					
Revenue	14,045.92	0.00	144,153.60	144,153.60	0.00
Expense	321,624.04	0.00	341,534.56	-341,534.56	0.00
Total Fund: 881 - OCCUPATIONAL INSURANCE ESCROW:	-307,578.12	0.00	-197,380.96	-197,380.96	0.00
Fund: 884 - GROUP HEALTH INSURANCE ESCROW					
Revenue	402,042.52	0.00	3,253,326.70	3,253,326.70	0.00
Expense	360,814.77	0.00	2,756,936.31	-2,756,936.31	0.00
Total Fund: 884 - GROUP HEALTH INSURANCE ESCROW:	41,227.75	0.00	496,390.39	496,390.39	0.00
Fund: 886 - WORKMAN'S COMP DEDUCTIBLE FUND					
Revenue	164.63	0.00	1,088.95	1,088.95	0.00
Expense	0.00	0.00	87.26	-87.26	0.00
Total Fund: 886 - WORKMAN'S COMP DEDUCTIBLE FUND:	164.63	0.00	1,001.69	1,001.69	0.00
Fund: 913 - 911 COMMISSION					
Revenue	131,648.61	0.00	1,182,176.14	1,182,176.14	0.00
Expense	132,283.09	0.00	1,315,431.68	-1,315,431.68	0.00
Total Fund: 913 - 911 COMMISSION:	-634.48	0.00	-133,255.54	-133,255.54	0.00
Report Total:	-825,715.29	-19,621,092.15	-941,388.96	18,679,703.19	-26,172,394.00

Fund Summary

Fund	March Activity	YTD Budget	YTD Activity	Variance Favorable (Unfavorable)	Total Budget
001 - GENERAL FUND	-44,075.47	4,745.16	-2,233,119.08	-2,237,864.24	0.00
010 - CASH FLOW RESERVE FUND	15,676.91	221,332.41	103,536.58	-117,795.83	295,192.00
011 - INSURANCE DEDUCTIBLE RE	101,574.35	74,999.97	108,003.81	33,003.84	100,000.00
030 - CAPITAL RESERVE	0.00	41.22	0.00	-41.22	0.00
031 - CAPITAL RSRV-BLDG MAINT	877.52	-84,504.42	-19,125.71	65,378.71	-112,638.00
032 - CIP LARGE VEHICLE/EQUIPM	0.00	-97,908.75	0.00	97,908.75	-130,545.00
110 - ROAD USE TAX	-54,106.55	-592,028.19	984,762.01	1,576,790.20	-789,388.00
111 - ROAD USE TAX INSURANCE	25,449.92	20,616.75	27,373.00	6,756.25	27,500.00
112 - EMPLOYEE BENEFITS FUND	-750,496.17	-1,012,403.07	-797,407.72	214,995.35	-1,351,432.00
117 - POLICE/FIRE RETIREMENT	-276,646.40	50,913.36	-275,695.05	-326,608.41	67,341.00
119 - EMERGENCY FUND	0.00	0.00	0.00	0.00	0.00
121 - LOCAL OPTION SALES TAX	-594,603.74	-1,101,427.20	481,947.59	1,583,374.79	-1,469,994.00
125 - TAX INCREMENT FINANCI	1,685.93	-427,802.22	50,025.92	477,828.14	-570,403.00
126 - TIF-LMI	39.06	21,496.14	296.13	-21,200.01	28,673.00
130 - CITY TORT LIABILITY	28,151.40	749.97	40,863.49	40,113.52	1,000.00
132 - GRANTS-STATE/LOCAL AGE	21.63	-157,125.69	103.63	157,229.32	-209,501.00
133 - UNDESIGNATED FEDERAL G	-444.00	17.46	6,317.00	6,299.54	0.00
139 - PLEASANT HILL POOL FOUN	-3,273.45	0.00	30,122.54	30,122.54	0.00
140 - PARK & REC DONATION FUI	1,272.32	-149,211.54	398,526.30	547,737.84	-198,949.00
141 - MTOWN TENNIS ASSOC	0.00	14.94	0.00	-14.94	20.00
142 - SOFTBALL ASSOCIATION FU	-415.40	7.74	10,075.89	10,068.15	0.00
144 - LIVE HEALTHY IOWA	44.89	2.07	296.48	294.41	2.00
149 - FEMA - WINDS	0.00	0.00	34,308.17	34,308.17	0.00
150 - LOCAL PD GRANTS	-161.38	0.00	-155.01	-155.01	0.00
151 - DEPT OF JUSTICE GRANTS	0.00	88.47	-3,129.00	-3,217.47	123.00
152 - POLICE UNDESIGNATED GR.	-739.08	20.79	-2,937.43	-2,958.22	0.00
153 - POLICE DEPT DONATION FL	373.46	-8,358.93	-854.44	7,504.49	-11,150.00
154 - AUTOMATED TRAFFIC ENFC	387.19	-84,695.40	-93,373.97	-8,678.57	-113,000.00
156 - FIRE DEPT DONATION FUNI	87.77	-15,970.50	-2,846.98	13,123.52	-21,298.00
160 - ECONOMIC DEVELOPMENT	176.00	749.97	-18,837.63	-19,587.60	1,000.00
161 - SURETY DEPOSITS/SUBDIVII	54.98	138.69	363.09	224.40	185.00
170 - LIBRARY DONATION FUND	-109,865.41	-307,698.48	131,702.50	439,400.98	-410,265.00
177 - SEIZED ASSETS (POLICE)	45.42	-1,874.43	4,837.02	6,711.45	-2,500.00
181 - #7 HUD LEAD GRANT	65,567.17	-539.46	89,333.12	89,872.58	0.00
184 - VOUCHERS - 002, 003	8,317.07	-5,387.40	47,460.75	52,848.15	-7,259.00
189 - #6 HUD LEAD GRANT/NOW	-9,745.81	0.00	-4,551.49	-4,551.49	0.00
200 - GO BONDS DEBT FUND	914,381.59	-29,396.97	3,367,260.64	3,396,657.61	-39,083.00
300 - CIP COLLECTION FUND	-305,147.08	-26,179.65	-151,428.20	-125,248.55	-34,906.00
311 - RISE STREET GRANTS	0.00	91.08	0.00	-91.08	1.00
312 - AIRPORT PROJECT FUND	631.67	-74,999.97	-58,767.61	16,232.36	-100,000.00

Monthly Budget Report - Marshalltown

For Fiscal: 2025-2026 Period Ending: 03/31/2026

340 - BIKE PATH PROJECT FUND	-22,647.10	0.09	-180,786.31	-180,786.40	0.00
341 - TREES FOREVER PROJECT	72.87	-3,150.09	4,452.53	7,602.62	-4,200.00
350 - GO BONDS CAPITAL PROJEC	0.00	-7,473.78	0.00	7,473.78	-9,965.00
355 - Dangerous & Dilapidated (ir	-992.19	-82,118.52	-189,816.87	-107,698.35	-109,490.00
362 - 2020 GO BONDS	0.00	0.00	0.00	0.00	0.00
363 - 2021 GO BONDS	280,189.02	-1,391,987.16	-3,586,394.54	-2,194,407.38	-1,855,983.00
364 - 2022 GO BONDS	-43,414.93	-2,762,822.34	-3,045,064.57	-282,242.23	-3,683,763.00
365 - 2023 GO BONDS	36,292.06	-6,779,334.69	293,542.14	7,072,876.83	-9,039,113.00
389 - AMERICAN RESCUE PLAN	0.00	-117,000.00	-88,181.84	28,818.16	-156,000.00
610 - WATER POLLUTION CONTRI	0.00	755.01	0.00	-755.01	0.00
611 - WPCP REVENUE	-215,695.76	-4,476,654.27	2,505,560.14	6,982,214.41	-5,968,912.00
614 - WPCP CAPITAL IMPROVEMI	5,372.87	37,499.94	35,484.61	-2,015.33	50,000.00
615 - WPCP PLANT & IMPROVEM	186,039.68	0.00	0.00	0.00	0.00
616 - SANITARY SEWER REHAB PF	0.00	0.00	0.00	0.00	0.00
617 - SANITARY SEWER NEW COM	0.00	5,249.97	432.00	-4,817.97	7,000.00
618 - WPCP INSURANCE RESERVE	101,338.25	74,970.00	106,444.47	31,474.47	100,000.00
690 - TRANSIT OPERATING	-63,914.25	-99,063.00	246,236.77	345,299.77	-132,461.00
691 - TRANSIT INSURANCE RESER	115.36	0.00	761.88	761.88	0.00
740 - STORM SEWER UTILITY	160,721.51	-238,499.55	496,730.53	735,230.08	-318,253.00
750 - COMPOSTING FACILITY	3,578.91	-1,843.65	50,210.60	52,054.25	-2,460.00
760 - P&R CONCESSIONS ENTERP	-1,047.68	1,865.97	-13,042.42	-14,908.39	2,480.00
881 - OCCUPATIONAL INSURANCI	-307,578.12	0.00	-197,380.96	-197,380.96	0.00
884 - GROUP HEALTH INSURANCI	41,227.75	0.00	496,390.39	496,390.39	0.00
886 - WORKMAN'S COMP DEDUC	164.63	0.00	1,001.69	1,001.69	0.00
913 - 911 COMMISION	-634.48	0.00	-133,255.54	-133,255.54	0.00
Report Total:	-825,715.29	-19,621,092.15	-941,388.96	18,679,703.19	-26,172,394.00



**MARSHALLTOWN
MORE THAN EVER**

**Mike Ladehoff, Mayor
Carol Webb, City Administrator
24 North Center Street
Marshalltown, IA 50158
PH 641.754.5701 • FX 641.754.5717**

To: Mayor and City Council
From: Christopher Jones, Police Chief
Meeting Date: May 11, 2026
Re: Resolution Accepting Bid and Authorizing the Purchase of a 2026 Polaris Ranger Crew XP 1000 for the Price of \$33,424 for Use in the Police Department and Declaring Certain Property Surplus Property and Authorizing Disposal Thereof

Strategic Plan Objective:

Continually improve and sustain the City's infrastructure, organization, and services. City policy requires the governing body to approve all vehicle purchases. This purchase will enhance city services provided by the police department by supplying staff with safe vehicles for agency operations.

Recommended:

Staff recommends the approval of the purchase of a new utility vehicle and the disposal by trade of an existing utility vehicle.

Budget Impact:

The CIP budget for FY27 has sufficient funds for this vehicle purchase. All vehicle-related payments will be made after July 1, 2026.

Description/Background:

Approximately 26 years ago, the police department purchased a Polaris Ranger Utility Vehicle to assist with department operations. Since that time, this vehicle has been used in various ways to aid our department. This vehicle has been used for police range maintenance, search and rescue operations (inside and outside Marshall County), bike path patrol, major events, and parade patrol, and has been the most-used vehicle for transporting and deploying our speed sign trailer. For the last couple of years, transmission concerns and outdated traffic safety equipment have made this vehicle unreliable and unsafe. Modern advancements in the utility vehicle market have made these vehicles much safer and easier to operate. Police Department staff is recommending the trade-in of our 2003 Polaris Ranger and the purchase of a new 2026 Polaris Ranger Crew XP 1000 for \$33,424. This vehicle will be used for public safety purposes only.

To ensure our agency has time to receive this vehicle purchase before our planned July 4th celebration and Ragbrai, the vehicle will be ordered, and payment will be made after July 1, 2026. This vehicle was scheduled for replacement in our FY26/27 Capital Budget Plan.

Attachments:

1. 2026-05-11_2026-081_Resolution for Purchase of UTV and Declaring 2003 UTV Surplus

RESOLUTION ACCEPTING BID AND AUTHORIZING THE PURCHASE OF A 2026 POLARIS RANGER CREW XP 1000 FOR THE PRICE OF \$33,424 FOR USE IN THE POLICE DEPARTMENT AS AN EMERGENCY RESPONSE UTILITY VEHICLE AND DECLARING CERTAIN PROPERTY SURPLUS PROPERTY AND AUTHORIZING DISPOSAL THEREOF

WHEREAS, the City of Marshalltown (hereinafter referred to as the “City”), State of Iowa, is a political subdivision organized and existing under the law and the Constitution of the State of Iowa (the “State”); and

WHEREAS, the City desires to procure a 2026 Polaris Ranger Crew XP 1000 from USS Polaris (Toledo, Iowa) as budgeted in the FY26-27 Capital Improvement Fund; and

WHEREAS, USS Polaris (Toledo, Iowa) submitted a bid for a total price of \$33,424; and

WHEREAS the City is the sole owner of the vehicle listed in Section 1; and

WHEREAS the acceptance of this bid and declaration of surplus property for trade purposes are in the best interests of the City of Marshalltown.

NOW, THEREFORE BE IT RESOLVED BY THE COUNCIL OF THE CITY OF MARSHALLTOWN, IOWA, AS FOLLOWS:

Section 1. The vehicle listed below is hereby declared as surplus property and shall be disposed of via trade to USS Polaris of Toledo, Iowa: 2003 Polaris Ranger Utility Vehicle, VIN: 4XARD50A02D826500 (Trade Value - \$1000).

Section 2. The City accepts the bid from USS Polaris of Toledo, Iowa for the purchase of one 2026 Polaris Ranger Crew XP 1000 for a total purchase price of \$33,424.

Section 3. The Chief of Police of the City is hereby authorized to enter into agreements on behalf of the City to purchase said vehicles at the above referenced price and conditions.

Passed this 11th day of May 2026, and signed this _____ day of May 2026.

CITY OF MARSHALLTOWN, IOWA

Mike Ladehoff, Mayor

ATTEST:

Alicia Hunter, CMC, City Clerk



**MARSHALLTOWN
MORE THAN EVER**

**Mike Ladehoff, Mayor
Carol Webb, City Administrator
24 North Center Street
Marshalltown, IA 50158
PH 641.754.5701 • FX 641.754.5717**

To: Mayor and City Council
From: Carol Webb, City Administrator
Meeting Date: May 11, 2026
Re: Resolution to Fix a Date for a Public Hearing on Proposed Ordinance Amendment to Increase a Franchise Fee Under the City's Gas Utility Franchise with Interstate Power & Light Company and to Adopt a Revenue Purpose Statement Related to the Franchise Fee

Strategic Plan Objective:

Continually improve and sustain the City's infrastructure, organization, and services.

Recommended:

Staff recommends approval.

Budget Impact:

Minimal administrative fees for setting a public hearing. If the Council does ultimately adopt a 3% franchise fee, there is the possibility of the public to petition for a special election. The estimated cost of a special election is \$15,000 to \$20,000. The net revenue from a 3% franchise fee is approximately \$1,000,000.

Description/Background:

City Council had a discussion at the April 13, 2026 City Council meeting regarding the proposal for implementation of a utility franchise fee for the City of Marshalltown. Council voted to move forward with implementation of a 3% electric and gas franchise fee to go towards property tax relief and public safety.

The full revenue purpose statement is included in these proceedings. In summary, the franchise fee revenue is proposed to be used as follows:

- Fees collected by the franchise fee shall be used for the purposes of inspecting, supervising, and otherwise regulating the (gas or electric) utility franchise.
- The funds in the account in excess of the amount necessary to inspect, supervise, or otherwise regulate the (gas or electric) utility franchise fees will be expended as follows:
 - A minimum of 33% of the excess franchise fee revenues collected shall be used for property tax relief.

- The funds in excess of the amount allocated for property tax relief will be used for public safety, including the equipping of fire, police, emergency services, sanitation, street, and civil defense departments.

Interstate Power and Light Company (Alliant Energy Corporation)

- The City of Marshalltown currently has franchise agreements for electric and gas.
- The proposed amendment will increase from a 0% franchise fee to a 3% franchise fee
- The current local option sales tax of 1% will not be charged

Consumers Energy

- The City of Marshalltown currently does not have a franchise agreement for electric. The proposed ordinance would establish a franchise agreement with a 3% franchise fee on electric.
- The current local option sales tax of 1% will not be charged

Dorsey and Whitney have prepared resolutions to set the public hearings for June 8, 2026, so the Council timeline is as follows:

- May 11, 2026 – Resolution adopting revenue purpose statement and setting public hearing.
- June 8, 2026 – Hold public hearings and first reading of the ordinances.
- June 22, 2026 – Second reading of the ordinances
- July 13, 2026 – Third reading of the ordinances

If a petition from the public is received, a Special Election will be called. The Marshall County Auditor's Office has provided the tentative timeline for a Special Election on 09/08/26.

- Public Measure Deadline: 07/24/26
- Satellite Petition Deadline: 08/07/26
- Absentee Begins: no earlier than 08/19/26
- Publication of Election Notice: between 08/19/26 and 09/04/26
- Worry-free postmark date: 08/24/26
- Pre-registration & Mailed Absentee Ballot Request Deadline: 08/24/26
- Last day to vote absentee - 9/07/26 (This is on the Labor Day holiday - State and County Offices closed, confirming date with the State)
- Election Day: 09/08/26

- Canvass: 09/19/26

Attachments:

1. 2026-05-11_2026-082_Set Hrg Franchise Fee Gas (Marshalltown #64 2026)-v1-v1

May 6, 2026

Alicia Hunter
City Clerk/City Hall
Marshalltown, Iowa

Re: Marshalltown, Iowa
Gas Utility Franchise Fee
Our File No. 422742-64

Dear Alicia:

We have prepared and attach proceedings for the May 11, 2026 City Council meeting to enable the City Council to adopt the resolution (the "Resolution") fixing the date for a hearing on the proposal to adopt an ordinance increasing the gas utility franchise fee and adopting a Revenue Purpose Statement.

The documents attached include the following items:

1. Minutes providing for the adoption of the Resolution. The Resolution follows the minutes.

The form of notice of hearing is set out in Section 2 of the resolution. Please print an extra copy for delivery to the publisher. Please insert the time and place of the hearing in both the resolution and the notice.

2. Certificate attesting the transcript.

3. Certificate with respect to publication of the notice, to which must be attached the publisher's affidavit of publication, if available, with a clipping of the notice as published.

The notice must be published at least once, not less than four (4) and not more than twenty (20) days before the meeting date set for the hearing, in a legal newspaper which has a general circulation in Marshalltown. **The last date on which the notice can be published effectively is June 4, 2026.** Please email a copy of the published notice to lemke.susan@dorsey.com.

As soon as possible after the Council meeting, please return one fully executed copy of all of the completed pages in these proceedings.

If you have any questions, please call John Danos or me.

Kind regards,

John P. Danos

cc: Carol Webb
Diana Steiner

MINUTES TO SET DATE FOR HEARING
ON PROPOSED ORDINANCE
INCREASING A FRANCHISE FEE AND
TO ADOPT REVENUE PURPOSE
STATEMENT

422742-64

Marshalltown, Iowa

May 11, 2026

The City Council of the City of Marshalltown, Iowa, met on May 11, 2026, at 5:30 p.m., at the City Council Chambers, 10 West State Street, in the City. The Mayor presided and the roll was called showing the following members of the Council present and absent:

Present: _____

Absent: _____.

Council Member _____ introduced the resolution hereinafter next set out and moved its adoption, seconded by Council Member _____; and after due consideration thereof by the Council, the Mayor put the question upon the adoption of the said resolution and the roll being called, the following named Council Members voted:

Ayes: _____

Nays: _____.

Whereupon, the Mayor declared the resolution duly adopted as hereinafter set out:

•••••

At the conclusion of the meeting, and upon motion and vote, the Council adjourned.

Mayor

Attest:

City Clerk

RESOLUTION NO. 2026-082

To fix a date for a public hearing on proposed ordinance amendment to increase a franchise fee under the City’s Gas Utility Franchise with Interstate Power & Light Company and to adopt a revenue purpose statement related to the franchise fee

WHEREAS, the City of Marshalltown (the “City”), in Marshall County, State of Iowa, has granted a gas utility franchise to Interstate Power & Light Company pursuant to City Ordinance No. 14806; and

WHEREAS, pursuant to the authority of Section 364.2 of the Code of Iowa, the City Council has now determined to increase the gas utility franchise fee (the “Franchise Fee”) to be imposed in connection with the provision of gas utility services within the City’s jurisdiction from 0% to 3.0%; and

WHEREAS, it is necessary to fix a date of a meeting of the City Council at which the Council will hold a public hearing on a proposed amendment to Ordinance No. 14806 to increase the Franchise Fee; and

WHEREAS, pursuant to the provisions of Section 364.2(4)(f) of the Code of Iowa, the City has prepared a Revenue Purpose Statement for the Use or Expenditure of Gas Utility Franchise Fee Revenues (the “Revenue Purpose Statement”) outlining the purposes for which the City shall use the Franchise Fee revenues that will be received if the proposed ordinance amendment is adopted, and it is now necessary for the City Council to take action to approve the Revenue Purpose Statement;

NOW, THEREFORE, Be It Resolved by the City Council of the City of Marshalltown, Iowa, as follows:

Section 1. The Revenue Purpose Statement attached hereto as Exhibit A is hereby finally approved and adopted, subject to its publication as set forth in Section 364.2(4)(f) of the Code of Iowa.

Section 2. This City Council shall meet on June 8, 2026, at the City Council Chambers, 10 West State Street, in the City, at 5:30 p.m., at which time and place a hearing will be held on a proposed amendment to Ordinance No. 14806 for the purpose of increasing the Franchise Fee.

Section 3. The City Clerk is hereby directed to give notice of the public hearing, the time when and place where the said meeting will be held and of the approved Revenue Purpose Statement, by publication at least once, not less than four (4) and not more than twenty (20) days before the date of said meeting, in a legal newspaper which has a general circulation in the City. The notice shall be in substantially the following form:

NOTICE OF PUBLIC HEARING ON PROPOSED ORDINANCE AMENDMENT INCREASING A FRANCHISE FEE UNDER THE CITY'S GAS UTILITY FRANCHISE WITH INTERSTATE POWER & LIGHT COMPANY AND PUBLICATION OF REVENUE PURPOSE STATEMENT FOR USE OF GAS UTILITY FRANCHISE FEE REVENUES BY THE CITY OF MARSHALLTOWN, IOWA

Notice is hereby given that the City Council of the City of Marshalltown will meet at the City Council Chambers, 10 West State Street, on June 8, 2026, at 5:30 p.m. to hold a public hearing on a proposed amendment to City Ordinance No. 14806, increasing the franchise fee (the "Franchise Fee") under the City's Gas Utility Franchise Agreement with Interstate Power & Light Company (the "Company") equal to 3% of the Company's gross revenues to be generated from sales of gas utility services in the City.

At the meeting, the City Council will receive oral or written objections from any resident or property owner of the City. Thereafter, the Council may, at the meeting or at an adjournment thereof, take additional action to adopt the proposed ordinance amendment or may abandon the proposal.

At any time before July 13, 2026, a petition may be filed with the City Clerk of the City asking that the question of amending City Ordinance No. 14806 to increase the Franchise Fee be submitted to the registered voters of the City, pursuant to the provisions of Section 364.2(4)(b) of the Code of Iowa. If no such petition is filed, the City Council may take up its third and final consideration of the proposal to amend Ordinance No. 14806 at the City Council meeting on said date.

Pursuant to the provisions of Section 364.2(4)(f) and a resolution of the City Council dated May 11, 2026, the City Council has adopted the following Revenue Purpose Statement, outlining the purposes for which the City shall use the franchise fee revenues that it will receive if the above-reference ordinance is adopted and approved.

Revenue Purpose Statement for Use or Expenditures of Gas Utility Franchise Fee Revenues for the City of Marshalltown, Iowa

Pursuant to the provisions of Section 364.2(4)(f) of the Code of Iowa, the City of Marshalltown, Iowa hereby establishes the following purposes for which franchise fee revenues from its Gas Utility Franchise with Interstate Power & Light Company to be deposited into a gas franchise fee account within the City's General Fund as required by Section 384.3A of the Iowa Code may be used or expended:

1. Moneys in the account shall be used for the purposes of inspecting, supervising, and otherwise regulating the Gas Utility Franchise.
2. Moneys in the account in excess of the amount necessary for the purpose specified in Item 1 above will be expended for the following:
 - a. A minimum of 33% of the fees will be used for property tax relief.

- b. The funds in excess of the amount allocated for property tax relief will be used for public safety, including the equipping of fire, police, emergency services, sanitation, street and civil defense departments.

Alicia Hunter
City Clerk

Section 4. All resolutions or parts of resolutions in conflict herewith are hereby repealed to the extent of such conflict.

Passed and approved May 11, 2026.

Mayor

Attest:

City Clerk

EXHIBIT A

***Revenue Purpose Statement for Use or Expenditures of Gas Utility Franchise Fee Revenues
for the City of Marshalltown, Iowa***

Pursuant to the provisions of Section 364.2(4)(f) of the Code of Iowa, the City of Marshalltown, Iowa hereby establishes the following purposes for which franchise fee revenues from its Gas Utility Franchise with Interstate Power & Light Company to be deposited into a gas utility franchise fee account within the City's General Fund as required by Section 384.3A of the Iowa Code may be used or expended:

1. Moneys in the account shall be used for the purposes of inspecting, supervising, and otherwise regulating the Gas Utility Franchise.

2. Moneys in the account in excess of the amount necessary for the purpose specified in Item 1 above will be expended for the following:

a. A minimum of 33% of the fees will be used for property tax relief.

b. The funds in excess of the amount allocated for property tax relief will be used for public safety, including the equipping of fire, police, emergency services, sanitation, street and civil defense departments.

STATE OF IOWA
MARSHALL COUNTY
CITY OF MARSHALLTOWN

SS:

I, the undersigned, City Clerk of the City of Marshalltown, Iowa, do hereby certify that attached hereto is a true and correct copy of the proceedings of the City Council relating to fixing a date for a hearing on the Council's proposal to amend an ordinance for the increase of a gas utility franchise fee and approving a Revenue Purpose Statement.

WITNESS MY HAND and this _____ day of _____, 2026.

City Clerk

(PLEASE NOTE: Do not date and return this certificate until you have received the publisher's affidavit and have verified that the notice was published on the date indicated in the affidavit but please return all other completed pages to us as soon as they are available.)

STATE OF IOWA
MARSHALL COUNTY
CITY OF MARSHALLTOWN

SS:

I, the undersigned, City Clerk of the City of Marshalltown, Iowa, do hereby certify that pursuant to the resolution of its City Council fixing a date of meeting at which it is proposed to take action to adopt an ordinance increasing a gas utility franchise fee, of which the printed slip attached to the publisher's affidavit hereto attached is a true and complete copy, was published on the date and in the newspaper specified in such affidavit, which newspaper has a general circulation in the City.

WITNESS MY HAND and this _____ day of _____, 2026.

City Clerk

(Attach here the publisher's original affidavit with clipping of the notice, as published.)



**MARSHALLTOWN
MORE THAN EVER**

**Mike Ladehoff, Mayor
Carol Webb, City Administrator
24 North Center Street
Marshalltown, IA 50158
PH 641.754.5701 • FX 641.754.5717**

To: Mayor and City Council
From: Carol Webb, City Administrator
Meeting Date: May 11, 2026
Re: Resolution to Fix a Date for a Public Hearing on Proposed Ordinance Amendment to Increase a Franchise Fee Under the City's Electric Utility Franchise with Interstate Power & Light Company and to Adopt a Revenue Purpose Statement Related to the Franchise Fee

Strategic Plan Objective:

Continually improve and sustain the City's infrastructure, organization, and services.

Recommended:

Staff recommends approval.

Budget Impact:

Minimal administrative fees for setting a public hearing. If the Council does ultimately adopt a 3% franchise fee, there is the possibility of the public to petition for a special election. The estimated cost of a special election is \$15,000 to \$20,000. The net revenue from a 3% franchise fee is approximately \$1,000,000.

Description/Background:

City Council had a discussion at the April 13, 2026 City Council meeting regarding the proposal for implementation of a utility franchise fee for the City of Marshalltown. Council voted to move forward with implementation of a 3% electric and gas franchise fee to go towards property tax relief and public safety.

The full revenue purpose statement is included in these proceedings. In summary, the franchise fee revenue is proposed to be used as follows:

- Fees collected by the franchise fee shall be used for the purposes of inspecting, supervising, and otherwise regulating the (gas or electric) utility franchise.
- The funds in the account in excess of the amount necessary to inspect, supervise, or otherwise regulate the (gas or electric) utility franchise fees will be expended as follows:
 - A minimum of 33% of the excess franchise fee revenues collected shall be used for property tax relief.

- The funds in excess of the amount allocated for property tax relief will be used for public safety, including the equipping of fire, police, emergency services, sanitation, street, and civil defense departments.

Interstate Power and Light Company (Alliant Energy Corporation)

- The City of Marshalltown currently has franchise agreements for electric and gas.
- The proposed amendment will increase from a 0% franchise fee to a 3% franchise fee.
- The current local option sales tax of 1% will not be charged

Consumers Energy

- The City of Marshalltown currently does not have a franchise agreement for electric. The proposed ordinance would establish a franchise agreement with a 3% franchise fee on electric.
- The current local option sales tax of 1% will not be charged

Dorsey and Whitney have prepared resolutions to set the public hearings for June 8, 2026, so the Council timeline is as follows:

- May 11, 2026 – Resolution adopting revenue purpose statement and setting public hearing.
- June 8, 2026 – Hold public hearings and first reading of the ordinances.
- June 22, 2026 – Second reading of the ordinances
- July 13, 2026 – Third reading of the ordinances

If a petition from the public is received, a Special Election will be called. The Marshall County Auditor’s Office has provided the tentative timeline for a Special Election on 09/08/26.

- Public Measure Deadline: 07/24/26
- Satellite Petition Deadline: 08/07/26
- Absentee Begins: no earlier than 08/19/26
- Publication of Election Notice: between 08/19/26 and 09/04/26
- Worry-free postmark date: 08/24/26
- Pre-registration & Mailed Absentee Ballot Request Deadline: 08/24/26
- Last day to vote absentee - 9/07/26 (This is on the Labor Day holiday - State and County Offices closed, confirming date with the State)
- Election Day: 09/08/26

- Canvass: 09/19/26

Attachments:

1. 2026-05-11_2026-083_Set Hrg Franchise Fee Electric (Marshalltown #64 2026)-v1-v1

May 6, 2026

Via Email

Alicia Hunter
City Clerk/City Hall
Marshalltown, Iowa

Re: Marshalltown, Iowa
Electric Utility Franchise Fee
Our File No. 422742-64

Dear Alicia:

We have prepared and attach proceedings for the May 11, 2026 City Council meeting to enable the City Council to adopt the resolution (the "Resolution") fixing the date for a hearing on the proposal to adopt an ordinance increasing the electric utility franchise fee and adopting a Revenue Purpose Statement.

The documents attached include the following items:

1. Minutes providing for the adoption of the Resolution. The Resolution follows the minutes.

The form of notice of hearing is set out in Section 2 of the resolution. Please print an extra copy for delivery to the publisher. Please insert the time and place of the hearing in both the resolution and the notice.

2. Certificate attesting the transcript.

3. Certificate with respect to publication of the notice, to which must be attached the publisher's affidavit of publication, if available, with a clipping of the notice as published.

The notice must be published at least once, not less than four (4) and not more than twenty (20) days before the meeting date set for the hearing, in a legal newspaper which has a general circulation in Marshalltown. **The last date on which the notice can be published effectively is June 4, 2026.** Please email a copy of the published notice to lemke.susan@dorsey.com.

As soon as possible after the Council meeting, please return one fully executed copy of all of the completed pages in these proceedings.

If you have any questions, please call John Danos or me.

Best regards,

Amy Bjork

cc: Carol Webb
Diana Steiner

MINUTES TO SET DATE FOR HEARING
ON PROPOSED ORDINANCE
INCREASING A FRANCHISE FEE AND
TO ADOPT REVENUE PURPOSE
STATEMENT

422742-64

Marshalltown, Iowa

May 11, 2026

The City Council of the City of Marshalltown, Iowa, met on May 11, 2026, at 5:30 p.m., at the City Council Chambers, 10 West State Street, in the City. The Mayor presided and the roll was called showing the following members of the Council present and absent:

Present: _____

Absent: _____.

Council Member _____ introduced the resolution hereinafter next set out and moved its adoption, seconded by Council Member _____; and after due consideration thereof by the Council, the Mayor put the question upon the adoption of the said resolution and the roll being called, the following named Council Members voted:

Ayes: _____

Nays: _____.

Whereupon, the Mayor declared the resolution duly adopted as hereinafter set out:

•••••

At the conclusion of the meeting, and upon motion and vote, the Council adjourned.

Mayor

Attest:

City Clerk

RESOLUTION NO. 2026-083

To fix a date for a public hearing on proposed ordinance amendment to increase a franchise fee under the City’s Electric Utility Franchise with Interstate Power & Light Company and to adopt a revenue purpose statement related to the franchise fee

WHEREAS, the City of Marshalltown (the “City”), in Marshall County, State of Iowa, has granted an electric utility franchise to Interstate Power & Light Company pursuant to City Ordinance No. 14807; and

WHEREAS, pursuant to the authority of Section 364.2 of the Code of Iowa, the City Council has now determined to increase the electric utility franchise fee (the “Franchise Fee”) to be imposed in connection with the provision of electric utility services within the City’s jurisdiction from 0% to 3.0%; and

WHEREAS, it is necessary to fix a date of a meeting of the City Council at which the Council will hold a public hearing on a proposed amendment to Ordinance No. 14807 to increase the Franchise Fee; and

WHEREAS, pursuant to the provisions of Section 364.2(4)(f) of the Code of Iowa, the City has prepared a Revenue Purpose Statement for the Use or Expenditure of Electric Utility Franchise Fee Revenues (the “Revenue Purpose Statement”) outlining the purposes for which the City shall use the Franchise Fee revenues that will be received if the proposed ordinance amendment is adopted, and it is now necessary for the City Council to take action to approve the Revenue Purpose Statement;

NOW, THEREFORE, Be It Resolved by the City Council of the City of Marshalltown, Iowa, as follows:

Section 1. The Revenue Purpose Statement attached hereto as Exhibit A is hereby finally approved and adopted, subject to its publication as set forth in Section 364.2(4)(f) of the Code of Iowa.

Section 2. This City Council shall meet on June 8, 2026, at the City Council Chambers, 10 West State Street, in the City, at 5:30 p.m., at which time and place a hearing will be held on a proposed amendment to Ordinance No. 14807 for the purpose of increasing the Franchise Fee.

Section 3. The City Clerk is hereby directed to give notice of the public hearing, the time when and place where the said meeting will be held and of the approved Revenue Purpose Statement, by publication at least once, not less than four (4) and not more than twenty (20) days before the date of said meeting, in a legal newspaper which has a general circulation in the City. The notice shall be in substantially the following form:

NOTICE OF PUBLIC HEARING ON PROPOSED ORDINANCE AMENDMENT INCREASING A FRANCHISE FEE UNDER THE CITY'S ELECTRIC UTILITY FRANCHISE WITH INTERSTATE POWER & LIGHT COMPANY AND PUBLICATION OF REVENUE PURPOSE STATEMENT FOR USE OF ELECTRIC UTILITY FRANCHISE FEE REVENUES BY THE CITY OF MARSHALLTOWN, IOWA

Notice is hereby given that the City Council of the City of Marshalltown will meet at the City Council Chambers, 10 West State Street, on June 8, 2026, at 5:30 p.m. to hold a public hearing on a proposed amendment to City Ordinance No. 14807, increasing a franchise fee (the "Franchise Fee") under the City's Electric Utility Franchise Agreement with Interstate Power & Light Company (the "Company") equal to 3% of the Company's gross revenues to be generated from sales of electric utility services in the City.

At the meeting, the City Council will receive oral or written objections from any resident or property owner of the City. Thereafter, the Council may, at the meeting or at an adjournment thereof, take additional action to adopt the proposed ordinance amendment or may abandon the proposal.

At any time before July 13, 2026, a petition may be filed with the City Clerk of the City asking that the question of amending City Ordinance No. 14807 to increase the Franchise Fee be submitted to the registered voters of the City, pursuant to the provisions of Section 364.2(4)(b) of the Code of Iowa. If no such petition is filed, the City Council may take up its third and final consideration of the proposal to amend Ordinance No. 14807 at the City Council meeting on said date.

Pursuant to the provisions of Section 364.2(4)(f) and a resolution of the City Council dated May 11, 2026, the City Council has adopted the following Revenue Purpose Statement, outlining the purposes for which the City shall use the franchise fee revenues that it will receive if the above-reference ordinance is adopted and approved.

Revenue Purpose Statement for Use or Expenditures of Electric Utility Franchise Fee Revenues for the City of Marshalltown, Iowa

Pursuant to the provisions of Section 364.2(4)(f) of the Code of Iowa, the City of Marshalltown, Iowa hereby establishes the following purposes for which franchise fee revenues from its Electric Utility Franchise with Interstate Power & Light Company to be deposited into an electric franchise fee account within the City's General Fund as required by Section 384.3A of the Iowa Code may be used or expended:

1. Moneys in the account shall be used for the purposes of inspecting, supervising, and otherwise regulating the Electric Utility Franchise.
2. Moneys in the account in excess of the amount necessary for the purpose specified in Item 1 above will be expended for the following:
 - a. A minimum of 33% of the fees will be used for property tax relief.

- b. The funds in excess of the amount allocated for property tax relief will be used for public safety, including the equipping of fire, police, emergency services, sanitation, street and civil defense departments.

Alicia Hunter
City Clerk

Section 4. All resolutions or parts of resolutions in conflict herewith are hereby repealed to the extent of such conflict.

Passed and approved May 11, 2026.

Mayor

Attest:

City Clerk

EXHIBIT A

Revenue Purpose Statement for Use or Expenditures of Electric Utility Franchise Fee Revenues for the City of Marshalltown, Iowa

Pursuant to the provisions of Section 364.2(4)(f) of the Code of Iowa, the City of Marshalltown, Iowa hereby establishes the following purposes for which franchise fee revenues from its Electric Utility Franchise with Interstate Power & Light Company to be deposited into an electric utility franchise fee account within the City's General Fund as required by Section 384.3A of the Iowa Code may be used or expended:

1. Moneys in the account shall be used for the purposes of inspecting, supervising, and otherwise regulating the Utility Franchise.
2. Moneys in the account in excess of the amount necessary for the purpose specified in Item 1 above will be expended for the following:
 - a. A minimum of 33% of the fees will be used for property tax relief.
 - b. The funds in excess of the amount allocated for property tax relief will be used for public safety, including the equipping of fire, police, emergency services, sanitation, street and civil defense departments.

STATE OF IOWA
MARSHALL COUNTY
CITY OF MARSHALLTOWN

SS:

I, the undersigned, City Clerk of the City of Marshalltown, Iowa, do hereby certify that attached hereto is a true and correct copy of the proceedings of the City Council relating to fixing a date for a hearing on the Council's proposal to amend an ordinance for the increase of an electric utility franchise fee and approving a Revenue Purpose Statement.

WITNESS MY HAND and this _____ day of _____, 2026.

City Clerk

(PLEASE NOTE: Do not date and return this certificate until you have received the publisher's affidavit and have verified that the notice was published on the date indicated in the affidavit but please return all other completed pages to us as soon as they are available.)

STATE OF IOWA
MARSHALL COUNTY
CITY OF MARSHALLTOWN

SS:

I, the undersigned, City Clerk of the City of Marshalltown, Iowa, do hereby certify that pursuant to the resolution of its City Council fixing a date of meeting at which it is proposed to take action to adopt an ordinance increasing an electric utility franchise fee, of which the printed slip attached to the publisher's affidavit hereto attached is a true and complete copy, was published on the date and in the newspaper specified in such affidavit, which newspaper has a general circulation in the City.

WITNESS MY HAND and this _____ day of _____, 2026.

City Clerk

(Attach here the publisher's original affidavit with clipping of the notice, as published.)



**MARSHALLTOWN
MORE THAN EVER**

**Mike Ladehoff, Mayor
Carol Webb, City Administrator
24 North Center Street
Marshalltown, IA 50158
PH 641.754.5701 • FX 641.754.5717**

To: Mayor and City Council
From: Carol Webb, City Administrator
Meeting Date: May 11, 2026
Re: Resolution to Fix a Date for a Public Hearing on Ordinance Granting an Electric Utility Franchise to Consumers Energy Cooperative, Establishing a Franchise Fee and Adopting a Revenue Purpose Statement Related to the Franchise Fee

Strategic Plan Objective:

Continually improve and sustain the City's infrastructure, organization, and services.

Recommended:

Staff recommends approval.

Budget Impact:

Minimal administrative fees for setting a public hearing. If the Council does ultimately adopt a 3% franchise fee, there is the possibility of the public to petition for a special election. The estimated cost of a special election is \$15,000 to \$20,000. The net revenue from a 3% franchise fee is approximately \$1,000,000.

Description/Background:

City Council had a discussion at the April 13, 2026 City Council meeting regarding the proposal for implementation of a utility franchise fee for the City of Marshalltown. Council voted to move forward with implementation of a 3% electric and gas franchise fee to go towards property tax relief and public safety.

The full revenue purpose statement is included in these proceedings. In summary, the franchise fee revenue is proposed to be used as follows:

- Fees collected by the franchise fee shall be used for the purposes of inspecting, supervising, and otherwise regulating the (gas or electric) utility franchise.
- The funds in the account in excess of the amount necessary to inspect, supervise, or otherwise regulate the (gas or electric) utility franchise fees will be expended as follows:
 - A minimum of 33% of the excess franchise fee revenues collected shall be used for property tax relief.

- The funds in excess of the amount allocated for property tax relief will be used for public safety, including the equipping of fire, police, emergency services, sanitation, street, and civil defense departments.

Interstate Power and Light Company (Alliant Energy Corporation)

- The City of Marshalltown currently has franchise agreements for electric and gas.
- The proposed amendment will increase from a 0% franchise fee to a 3% franchise fee.
- The current local option sales tax of 1% will not be charged

Consumers Energy

- The City of Marshalltown currently does not have a franchise agreement for electric. The proposed ordinance would establish a franchise agreement with a 3% franchise fee on electric.
- The current local option sales tax of 1% will not be charged

Dorsey and Whitney have prepared resolutions to set the public hearings for June 8, 2026, so the Council timeline is as follows:

- May 11, 2026 – Resolution adopting revenue purpose statement and setting public hearing.
- June 8, 2026 – Hold public hearings and first reading of the ordinances.
- June 22, 2026 – Second reading of the ordinances
- July 13, 2026 – Third reading of the ordinances

If a petition from the public is received, a Special Election will be called. The Marshall County Auditor's Office has provided the tentative timeline for a Special Election on 09/08/26.

- Public Measure Deadline: 07/24/26
- Satellite Petition Deadline: 08/07/26
- Absentee Begins: no earlier than 08/19/26
- Publication of Election Notice: between 08/19/26 and 09/04/26
- Worry-free postmark date: 08/24/26
- Pre-registration & Mailed Absentee Ballot Request Deadline: 08/24/26
- Last day to vote absentee - 9/07/26 (This is on the Labor Day holiday - State and County Offices closed, confirming date with the State)
- Election Day: 09/08/26

- Canvass: 09/19/26

Attachments:

1. 2026-05-11_2026-084_Set Hrg Grant Franchise & Impose Fee Electric (Consumers)
(Marshalltown #64 2026)-v1-v1

May 6, 2026

Via Email

Alicia Hunter
City Clerk/City Hall
Marshalltown, Iowa

Re: Marshalltown, Iowa
Electric Utility Franchise Fee
Our File No. 422742-64

Dear Alicia:

We have prepared and attach proceedings for the May 11, 2026 City Council meeting to enable the City Council to adopt the resolution (the “Resolution”) fixing the date for a hearing on the proposal to adopt an ordinance granting an electric utility franchise, establishing an electric utility franchise fee and adopting a Revenue Purpose Statement.

The documents attached include the following items:

1. Minutes providing for the adoption of the Resolution. The Resolution follows the minutes.

The form of notice of hearing is set out in Section 2 of the resolution. Please print an extra copy for delivery to the publisher. Please insert the time and place of the hearing in both the resolution and the notice.

2. Certificate attesting the transcript.

3. Certificate with respect to publication of the notice, to which must be attached the publisher’s affidavit of publication, if available, with a clipping of the notice as published.

The notice must be published at least once, not less than four (4) and not more than twenty (20) days before the meeting date set for the hearing, in a legal newspaper which has a general circulation in Marshalltown. **The last date on which the notice can be effectively published in June 4, 2026.** Please email a copy of the published notice to ritter.cheryl@dorsey.com.

As soon as possible after the Council meeting, please return one fully executed copy of all of the completed pages in these proceedings.

If you have any questions, please call Amy Bjork or me.

Best regards,

John P. Danos

MINUTES TO SET DATE FOR HEARING
ON PROPOSED ORDINANCE
GRANTING ELECTRIC FRANCHISE
AND ESTABLISHING FRANCHISE FEE
AND TO ADOPT REVENUE PURPOSE
STATEMENT

422742-64

Marshalltown, Iowa

May 11, 2026

The City Council of the City of Marshalltown, Iowa, met on May 11, 2026, at 5:30 p.m., at the City Council Chambers, 10 West State Street, in the City. The Mayor presided and the roll was called showing the following members of the Council present and absent:

Present: _____

Absent: _____.

Council Member _____ introduced the resolution hereinafter next set out and moved its adoption, seconded by Council Member _____; and after due consideration thereof by the Council, the Mayor put the question upon the adoption of the said resolution and the roll being called, the following named Council Members voted:

Ayes: _____

Nays: _____.

Whereupon, the Mayor declared the resolution duly adopted as hereinafter set out:

•••••

At the conclusion of the meeting, and upon motion and vote, the Council adjourned.

Mayor

Attest:

City Clerk

RESOLUTION NO. 2026-084

Resolution to fix a date for a public hearing on ordinance granting an electric utility franchise to Consumers Energy Cooperative, establishing a franchise fee and adopting a revenue purpose statement related to the franchise fee

WHEREAS, the City of Marshalltown (the “City”), in Marshall County, State of Iowa, proposes to grant a nonexclusive electric utility franchise to Consumers Energy Cooperative pursuant to the provisions of Chapter 364 of the Code of Iowa; and

WHEREAS, pursuant to Section 364.2 of the Code of Iowa, the franchise may only be granted by ordinance; and

WHEREAS, the City Council has determined to include an electric utility franchise fee (the “Franchise Fee”) of 3.0% to be imposed in connection with the provision of electric utility services within the City’s jurisdiction, in such ordinance; and

WHEREAS, it is necessary to fix the date of a meeting of the City Council at which the Council will hold a public hearing on the proposed ordinance to grant a franchise to Consumers Energy Cooperative, and to give notice thereof as required by such law, including notice of the right to petition for an election on such proposal; and

WHEREAS, pursuant to the provisions of Section 364.2(4)(f) of the Code of Iowa, the City has prepared a Revenue Purpose Statement for the Use or Expenditure of Electric Utility Franchise Fee Revenues (the “Revenue Purpose Statement”) outlining the purposes for which the City shall use the Franchise Fee revenues that will be received if the proposed ordinance is adopted, and it is now necessary for the City Council to take action to approve the Revenue Purpose Statement;

NOW, THEREFORE, Be It Resolved by the City Council of the City of Marshalltown, Iowa, as follows:

Section 1. The Revenue Purpose Statement attached hereto as Exhibit A is hereby finally approved and adopted, subject to its publication as set forth in Section 364.2(4)(f) of the Code of Iowa.

Section 2. This City Council shall meet on June 8, 2026, at the City Council Chambers, 10 West State Street, in the City, at 5:30 p.m., at which time and place a hearing will be held on the proposed ordinance to grant a franchise to Consumers Energy Cooperative and to establish an electric utility Franchise Fee.

Section 3. The City Clerk is hereby directed to give notice of the public hearing, the time when and place where the said meeting will be held and of the approved Revenue Purpose Statement, by publication at least once, not less than four (4) and not more than twenty (20) days before the date of said meeting, in a legal newspaper which has a general circulation in the City. The notice shall be in substantially the following form:

NOTICE OF PUBLIC HEARING ON PROPOSED ORDINANCE GRANTING AN ELECTRIC UTILITY FRANCHISE TO CONSUMERS ENERGY COOPERATIVE AND ESTABLISHING A FRANCHISE FEE THEREIN AND PUBLICATION OF REVENUE PURPOSE STATEMENT FOR USE OF ELECTRIC UTILITY FRANCHISE FEE REVENUES BY THE CITY OF MARSHALLTOWN, IOWA

Notice is hereby given that the City Council of the City of Marshalltown, Iowa will meet at the City Council Chambers, 10 West State Street, on June 8, 2026, at 5:30 p.m. to hold a public hearing on a proposed ordinance granting an electric utility franchise to Consumers Energy Cooperative (the “Cooperative”) and establishing a franchise fee therein equal to 3.0% of the Cooperative’s gross revenues to be generated from sales of electric utility services in the City.

At the meeting, the City Council will receive oral or written objections from any resident or property owner of the City. Thereafter, the Council may, at the meeting or at an adjournment thereof, take additional action to adopt the proposed ordinance or may abandon the proposal.

At any time before July 13, 2026, a petition may be filed with the City Clerk of the City asking that the question of adopting the ordinance granting the franchise and establishing the franchise fee be submitted to the registered voters of the City, pursuant to the provisions of Section 364.2(4)(b) of the Code of Iowa. If no such petition is filed, the City Council may take up its third and final consideration of the proposed ordinance at the City Council meeting on said date.

Pursuant to the provisions of Section 364.2(4)(f) and a resolution of the City Council dated May 11, 2026, the City Council has adopted the following Revenue Purpose Statement, outlining the purposes for which the City shall use the franchise fee revenues that it will receive if the above-reference ordinance is adopted and approved.

Revenue Purpose Statement for Use or Expenditures of Electric Utility Franchise Fee Revenues for the City of Marshalltown, Iowa

Pursuant to the provisions of Section 364.2(4)(f) of the Code of Iowa, the City of Marshalltown, Iowa hereby establishes the following purposes for which franchise fee revenues from its Electric Utility Franchise with Consumers Energy Cooperative to be deposited into an electric franchise fee account within the City’s General Fund as required by Section 384.3A of the Iowa Code may be used or expended:

1. Moneys in the account shall be used for the purposes of inspecting, supervising, and otherwise regulating the Electric Utility Franchise.
2. Moneys in the account in excess of the amount necessary for the purpose specified in Item 1 above will be expended for the following:
 - a. A minimum of 33% of the fees will be used for property tax relief.

- b. The funds in excess of the amount allocated for property tax relief will be used for public safety, including the equipping of fire, police, emergency services, sanitation, street and civil defense departments.

Alicia Hunter
City Clerk

Section 4. All resolutions or parts of resolutions in conflict herewith are hereby repealed to the extent of such conflict.

Passed and approved May 11, 2026.

Mayor

Attest:

City Clerk

EXHIBIT A

***Revenue Purpose Statement for Use or Expenditures of Electric Utility Franchise Fee
Revenues for the City of Marshalltown, Iowa***

Pursuant to the provisions of Section 364.2(4)(f) of the Code of Iowa, the City of Marshalltown, Iowa hereby establishes the following purposes for which franchise fee revenues from its Electric Utility Franchise with Consumers Energy Cooperative to be deposited into an electric utility franchise fee account within the City's General Fund as required by Section 384.3A of the Iowa Code may be used or expended:

1. Moneys in the account shall be used for the purposes of inspecting, supervising, and otherwise regulating the Electric Utility Franchise.
2. Moneys in the account in excess of the amount necessary for the purpose specified in Item 1 above will be expended for the following:
 - a. A minimum of 33% of the fees will be used for property tax relief.
 - b. The funds in excess of the amount allocated for property tax relief will be used for public safety, including the equipping of fire, police, emergency services, sanitation, street and civil defense departments.

STATE OF IOWA
MARSHALL COUNTY
CITY OF MARSHALLTOWN

SS:

I, the undersigned, City Clerk of the City of Marshalltown, Iowa, do hereby certify that attached hereto is a true and correct copy of the proceedings of the City Council relating to fixing a date for a hearing on the Council's proposed ordinance granting an electric utility franchise to Consumers Energy Cooperative and establishing an electric utility franchise fee, and approving a Revenue Purpose Statement.

WITNESS MY HAND and this _____ day of _____, 2026.

City Clerk

(PLEASE NOTE: Do not date and return this certificate until you have received the publisher's affidavit and have verified that the notice was published on the date indicated in the affidavit but please return all other completed pages to us as soon as they are available.)

STATE OF IOWA
MARSHALL COUNTY
CITY OF MARSHALLTOWN

SS:

I, the undersigned, City Clerk of the City of Marshalltown, Iowa, do hereby certify that pursuant to the resolution of its City Council fixing a date of meeting at which it is proposed to take action to adopt an ordinance granting an electric utility franchise to Consumers Energy Cooperative and establishing an electric utility franchise fee, and approving a Revenue Purpose Statement, the notice, of which the printed slip attached to the publisher's affidavit hereto attached is a true and complete copy, was published on the date and in the newspaper specified in such affidavit, which newspaper has a general circulation in the City.

WITNESS MY HAND and this _____ day of _____, 2026.

City Clerk

(Attach here the publisher's original affidavit with clipping of the notice, as published.)



**MARSHALLTOWN
MORE THAN EVER**

**Mike Ladehoff, Mayor
Carol Webb, City Administrator
24 North Center Street
Marshalltown, IA 50158
PH 641.754.5701 • FX 641.754.5717**

To: Mayor and City Council
From: Diana Steiner, Finance Director
Meeting Date: May 11, 2026
Re: Resolution to approve transfers for the 9 month period ending March 31, 2026

Strategic Plan Objective:

Continually improve and sustain the City's infrastructure, organization, and services.

Recommended:

Staff recommends Council approve transfers that were budgeted and additional transfers that are now needed for the first 9 months of fiscal year 2026

Budget Impact:

A budget amendment is not required if actual transfers exceed the budgeted transfer amounts; however, Council approval is required to actually make the transfers if the budget is exceeded. The resolution shows the original adopted FY26 budget approved in April 2025 and the actual transfers made this fiscal year through March 31, 2026.

Description/Background:

Effective April 13, 2019, the City Finance Committee, organized under Iowa Administrative Code, approved changes to Administrative Rules Code 545-2 requiring greater disclosures for all interfund transfers. The rules require cities to provide the originating fund and receiving fund, purpose, and amount of the transfer during the budget process and also require additional resolutions any time transfers exceed the original or amended budget amounts.

Within the resolution, staff have outlined the original adopted budget transfers for the fiscal year ending June 30, 2026 and the actual transfers needed for the 9-month period ending March 31, 2026, and the difference between the budget and the actual transfer. In many instances, the revenue from property tax levies, road use tax, local option sales tax, and bond funds are shown in their originating fund and then transferred out to the fund where the expenditures are accounted for.

For the rows highlighted in yellow, there will be a budget starting with the April 2026 financial

statements as this will reflect the budget amendment approved at the April 27, 2026 Council meeting.

Attachments:

1. Transfers for FY26 budget through 3.31.26

WHEREAS, the fiscal year 2026 budget provides for certain transfers between funds; and,

WHEREAS, the books should now indicate appropriate transfers;

THEREFORE, IT IS HEREBY RESOLVED BY THE CITY COUNCIL OF THE CITY OF MARSHALLTOWN, IOWA

that the Finance Director be directed to make said transfers as follows:

TRANSFERS BETWEEN FUNDS FOR FISCAL YEAR 2026

Fund	Transferred From	Fund	Transferred To	Explanation of activity	FY26 Adopted Budget	Transfers through March 31, 2026	Remaining Budget Available
001	General fund	355	D&D Fund	Landfill revenue in excess of expenses for prior fiscal year	10.00	-	10.00
001	General fund	149	FEMA-Wind	Wages posted to fund 149 after FEMA paperwork submitted.	-	206.51	(206.51)
001	General fund	152	Dept of Justice Grants	Expenditure wages exceeded available grant funds	-	277.59	(277.59)
001	General fund	341	Trees Forever	Revenue for Home Show Booth was in general fund. Expenses in fund 341 from prior fiscal year. Transfer needed to make project whole..	-	225.00	(225.00)
001	General fund	690	Transit	Property taxes collected in general (as required) with the cash being transferred to the transit enterprise fund	414,638.00	250,281.48	164,356.52
030	Capital Reserve	312	Airport Project Fund	City portion of Airport Grant Project	51,500.00	18,000.00	33,500.00
030	Capital Reserve	363	2021 GO Bonds	Reimburse bond funds for Kiwanis Park Improvements paid in prior fiscal years	-	272,328.68	(272,328.68)
110	Road use tax fund	001	General	Reimbursement to general fund for employee wages associated with the public works department	1,254,942.00	945,197.28	309,744.72
110	Road use tax fund	111	RUT Ins Reserve	Reserve for property insurance deductibles in case of a natural disaster.	25,000.00	25,000.00	-
110	Road use tax fund	363	2021 Go Bonds	Railroad quiet zone	642,803.00	-	642,803.00
112	Employee benefits fund	001	General	Reimbursement to general fund for employee benefits: FICA, IPERS, group health insurance, workman 's comp, retirees health savings contributions (non-union payout in lieu of sick and vacation based upon guidelines for payouts)	3,903,397.00	2,495,605.47	1,407,791.53
112	Employee benefits fund	110	Road Use Tax	Reimbursement to RUT fund for employee benefits: FICA, IPERS, group health insurance, workman 's comp, retirees health savings contributions (non-union payout in lieu of sick and vacation based upon guidelines for payouts)	-	1,833.42	(1,833.42)
117	Police & fire retirement	001	General	Reimbursement to general fund for civil service retirement payments to Municipal Fire & Police Retirement System of Iowa (MFPRSI)	1,358,872.00	976,689.20	382,182.80
119	Emergency Levy Fund	001	General	Property taxes collected for prior year in Emergency fund with the cash being transferred to the general fund	-	0.70	(0.70)
121	LOST - Council Desig	001	General	Council Designated to offset General Fund deficit	1,076,145.00	-	1,076,145.00
121	LOST - Council Desig	010	Cash Flow Reserve Fund	Transfer to have Reserve Fund at 18% fund 001 budgeted expenses	205,192.00	-	205,192.00
121	LOST - Council Desig	011	Insurance Deductible Reserve Fund	Reserve for property insurance deductibles in case of a natural disaster. General fund costs only.	100,000.00	100,000.00	-
121	LOST - Council Desig	031	Capital Reserve - Bldg. Maint.	Fund deficit in fund for capital projects needed	86,528.00	-	86,528.00
121	Local Option Sales Tax	200	Debt Service Fund	Property tax relief from local option sales tax (LOST) collected to pay for bond payments	3,350,000.00	2,534,281.15	815,718.85
121	Local Option Sales Tax	311	RISE Street Grants	Edgewood extension	80,854.00	-	80,854.00
121	Local Option Sales Tax	364	2022 GO Bonds	E. Main & Center; Crack & Joint Seals	381,465.00	-	381,465.00
125	TIF tax collection fund	001	General	M CBD, Chamber, and façade/code grant expenses paid by general fund. Cash is transferred from TIF collection fund where the property taxes are collected.	250,600.00	155,972.50	94,627.50

Fund	Transferred From	Fund	Transferred To	Explanation of activity	FY26 Adopted Budget	Transfers through March 31, 2026	Remaining Budget Available
125	TIF tax collection fund	200	Debt Service Fund	To Pay for TIF portion of GO Debt	281,451.00	-	281,451.00
132	Grants - State, Local Agencies	110	Road Use Tax	Traffic Signal Grant for Hwy 30 EB/Hwy 14	390,000.00	-	390,000.00
140	P&R Donation Fund	364	2022 GO Bonds	Fundraised donations to be unred at Linn Creek Project	391,749.00	-	391,749.00
152	Police Undesignated Grants	001	General	Reimb. General Fund for FEMA national emergency training	-	566.40	(566.40)
300	CIP Tax Collection Fund	030	Capital Improvement Reserve Fund	Capital expenditures paid from governmental capital reserve fund. Cash is transferred from the capital improvement levy funds where the property taxes were received.	668,030.00	600,979.96	67,050.04
300	CIP Tax Collection Fund	32	CIP Large Equipment	Capital expenditures paid from governmental capital reserve fund. Cash is transferred from the capital improvement levy funds where the property taxes were received. For future fire truck purchase.	104,955.00	-	104,955.00
341	Trees Forever	140	P&R Donation Fund	Credit Card rebate was posted to the wrong fund.	-	0.81	(0.81)
350	GO Bonds Capital	311	RISE Street Grants	Close out fund	10,165.00	-	10,165.00
363	2021 GO Bonds	030	Capital Improvement	Credit Card rebate was posted to the wrong fund.	-	35.90	(35.90)
363	2021 GO Bonds	364	2022 GO Bonds	E MainSt/Center St Reconstruction. Reallocate projects so can get the oldest bond spent first.	35,000.00	3,415,144.35	(3,380,144.35)
364	2022 GO Bonds & Projects	140	Parks & Rec Donation Fund	The Destination Iowa grant expenditures for the Linn Creek District playhouse project are in fund 140. All grant funds are deposited in fund 364 and then a transfer is made for the playhouse project portion.	-	183,291.65	(183,291.65)
364	2022 GO Bonds & Projects	311	RISE Street Grants	Engineering for Highland Acres Road	250,000.00	-	250,000.00
364	2022 GO Bonds & Projects	340	Bike Path Project Fund	6th St Trail Legion to Skatepark	-	4,013.54	(4,013.54)
364	2022 GO Bonds & Projects	362	2020 GO Bonds	Exchanged project funding to cover arbitrage repayment on 2020A bond. Too much interest earned. Council approved transfer on Resolution 2025-261	-	47,505.66	(47,505.66)
364	2022 GO Bonds & Projects	740	Storm Sewer Utility	208 Leo St Levee Access \$25,000; Sth St & Hughes Storm Sewer Repair & Improvement \$107,544	-	87,877.34	(87,877.34)
365	2023 GO Bonds	363	2021 GO Bonds	Railroad quiet zone \$296,277; South Center St Viaduct \$2,257,769, State St. Reconstruction \$26,326	-	9,568.51	(9,568.51)
365	2023 GO Bonds	364	2022 GO Bonds & Projects	Downtown Phase 2 for E Main	7,073,863.00	-	7,073,863.00
610	WPCP	200	Debt Service Fund	Fund WPCP GO Bond Payments	505,118.00	5,168.00	499,950.00
740	Storm Sewer Utility	200	Debt Service Fund	Fund Storm Sewer GO Bond Payments	548,660.00	21,935.00	526,725.00
TOTAL FOR BUDGET					\$ 23,440,937.00	\$ 12,151,986.10	\$ 11,288,950.90
610/611/615	WPCP funds	610, 612,615, 616, 617	WPCP funds	Cover consolidation of project funds within WPCP series and move dollars from WPCP revenue fund to WPCP expenditure fund	14,261,412.00	4,426,395.27	9,835,016.73
TOTALS INCLUDING INTERFUND TRANSFERS					37,702,349.00	16,578,381.37	21,123,967.63

Passed this 11th day of May 2026.

Attest: _____

Mayor

Attest: _____

City Clerk



**MARSHALLTOWN
MORE THAN EVER**

**Mike Ladehoff, Mayor
Carol Webb, City Administrator
24 North Center Street
Marshalltown, IA 50158
PH 641.754.5701 • FX 641.754.5717**

To: Mayor and City Council
From: Ben Daleske, Engineer, Heather Thomas, Public Works Director
Meeting Date: May 11, 2026
Re: Resolution Approving Engineer's Certificate of Completion and Accepting Cedar Falls Construction for 2025 PCC Patch Repair Project, #STR23002

Strategic Plan Objective:

This work falls into City Strategy 3: Continually improve and sustain the City's infrastructure, organization, and services.

Recommended:

Staff recommends approval of final completion for the PCC Patch Repair project and authorize release of retainage following 30 days of no claims following acceptance of completion.

Budget Impact:

This capital project was sufficiently funded. following numbers are shown as a FYI to understand project costs and where funding is coming from:

PCC Patch Repair Construction Costs:

Change Order #2	\$ 16,193.96	
Change Order #1	\$ 150,977.74	
Construction Base	\$ 305,476.00	Cedar Falls Construction Co.
	\$ 472,647.70	TOTAL

Funding Sources (PCC Patch Repair)

SIP Funds - Fund 363 Bond	\$455,558.27	
SIP Funds - Fund 364 Bond	\$17,089.43	
	\$ 472,647.70	TOTAL

Description/Background:

The Contractor has completed all requirements of this construction contract, submitted necessary records, and the Engineer is recommending accepting this construction contract as complete.

The Contractor completed the project within the contract completion provisions.

The project completion dates are:

Substantial Completion: November 1, 2025

Engineer’s Notice of Final Acceptance & Certificate of Completion: May 1, 2026

Council Approval of Completion: May 11, 2026

The substantial completion certificate indicates the date at which the project was sufficiently complete so that the work can be utilized for the purposes for which it was intended and also the date when the warranty/bond period begins. This was within the time of completion allowed by the construction contract, as amended. There is a 4-year warranty bond that is in effect until 4 years after project substantial completion (November 1, 2029).

With the Council’s approval this evening of completion. Pending no claims, the city may release project retainage that was held after 30 days, but no later than 40 days from today’s date.

Attachments:

- 1. 2026-05-11_2026-086_Resolution Approving Eng Certificate Completion PCC Patch STR23002
- 2. STR23-002 SOSC and NOA

RESOLUTION APPROVING ENGINEER'S CERTIFICATE OF COMPLETION AND ACCEPTING CEDAR FALLS CONSTRUCTION, INC FOR THE PCC PATCH REPAIR PROJECT #STR23002

WHEREAS, the City of Marshalltown, Iowa has heretofore entered into a contract for labor and material for the PCC Patch Repair Project #STR23002; and

WHEREAS, said project has been completed by Cedar Falls Construction Co, Inc, pursuant to the plans and specifications all as is set forth in the Final Acceptance and Certificate of Completion covering said project.

NOW, THEREFORE, BE IT RESOLVED BY THE COUNCIL OF THE CITY OF MARSHALLTOWN, IOWA;

Section 1. That the labor and material for the PCC Patch Repair Project, being project #STR23002, is hereby accepted pursuant to the Engineer's Final Acceptance and Certificate of Completion and the City Clerk is hereby authorized and directed to do all things necessary to complete the contract with Cedar Falls Construction Co, Inc, including the payment of the items called for in said contract and Certificate of Completion.

Passed this 11th day of May 2026 and signed this _____ day of May 2026.

CITY OF MARSHALLTOWN, IOWA

Mike Ladehoff, Mayor

ATTEST:

Alicia Hunter, CMC, City Clerk

CERTIFICATE OF SUBSTANTIAL COMPLETION

Owner:	City of Marshalltown	Owner's Project No.:	STR23-002
Construction Engineer:	City of Marshalltown	Engineer's Project No.:	STR23-002
Contractor:	Cedar Falls Construction Co. Inc	Contractor's Project No.:	
Project:	2025 PCC Patch Repair Project		
Contract Name:	2025 PCC Patch Repair Project, STR23-002 Plus Change Order #1 & 2		

This Preliminary Final Certificate of Substantial Completion applies to:

All Work The following specified portions of the Work:

All work as provided in the plans and as amended by change order.

Date of Substantial Completion: November 1, 2025

The Work to which this Certificate applies has been inspected by authorized representatives of Owner, Contractor, and Engineer, and found to be substantially complete. The Date of Substantial Completion of the Work or portion thereof designated above is hereby established, subject to the provisions of the Contract pertaining to Substantial Completion. The date of Substantial Completion in the final Certificate of Substantial Completion marks the commencement of the contractual correction period and applicable warranties required by the Contract.

A punch list of items to be completed or corrected is attached to this Certificate. This list may not be all-inclusive, and the failure to include any items on such list does not alter the responsibility of the Contractor to complete all Work in accordance with the Contract Documents.

Amendments of contractual responsibilities recorded in this Certificate should be the product of mutual agreement of Owner and Contractor; see Paragraph 15.03.D of the General Conditions.

The responsibilities between Owner and Contractor for security, operation, safety, maintenance, heat, utilities, insurance, and warranties upon Owner's use or occupancy of the Work must be as provided in the Contract, except as amended as follows:

Amendments to Owner's Responsibilities: None As follows:

None

Amendments to Contractor's Responsibilities: None As follows:

None

The following documents are attached to and made a part of this Certificate:

Notice of Acceptability

This Certificate does not constitute an acceptance of Work not in accordance with the Contract Documents, nor is it a release of Contractor's obligation to complete the Work in accordance with the Contract Documents.

Engineer



By (signature):

Name (printed):

Ben Daleske, P.E.

Title:

Civil Engineer II

NOTICE OF ACCEPTABILITY OF WORK

Owner:	City of Marshalltown	Owner's Project No.:	STR23-002
Construction Engineer:	City of Marshalltown	Engineer's Project No.:	STR23-002
Contractor:	Cedar Falls Construction Co. Inc	Contractor's Project No.:	
Project:	2025 PCC Patch Repair Project		
Contract Name:	2025 PCC Patch Repair Project, STR23-002 Plus Change Order #1 & 2		

Notice Date: May 1, 2026 Effective Date of the Construction Contract: September 19, 2025

The Engineer hereby gives notice to the Owner and Contractor that Engineer recommends final payment to Contractor, and that the Work furnished and performed by Contractor under the Construction Contract is acceptable, expressly subject to the provisions of the Construction Contract's Contract Documents ("Contract Documents"). This Notice of Acceptability of Work (Notice) is made expressly subject to the following terms and conditions to which all who receive and rely on said Notice agree:

This Notice has been prepared with the skill and care ordinarily used by members of the engineering profession practicing under similar conditions at the same time and in the same locality.

This Notice reflects and is an expression of the Engineer's professional opinion.

This Notice has been prepared to the best of Engineer's knowledge, information, and belief as of the Notice Date.

This Notice is based entirely on and expressly limited by the scope of services Engineer has been employed by Owner to perform or furnish during construction of the Project (including observation of the Contractor's Work) under the Owner-Engineer Agreement, and applies only to facts that are within Engineer's knowledge or could reasonably have been ascertained by Engineer as a result of carrying out the responsibilities specifically assigned to Engineer under such Owner-Engineer Agreement.

This Notice is not a guarantee or warranty of Contractor's performance under the Construction Contract, an acceptance of Work that is not in accordance with the Contract Documents, including but not limited to defective Work discovered after final inspection, nor an assumption of responsibility for any failure of Contractor to furnish and perform the Work thereunder in accordance with the Contract Documents, or to otherwise comply with the Contract Documents or the terms of any special guarantees specified therein.

This Notice does not relieve Contractor of any surviving obligations under the Construction Contract, and is subject to Owner's reservations of rights with respect to completion and final payment.

Engineer

By *(signature)*:  _____

Name *(printed)*: Ben Daleske, P.E.

Title: Civil Engineer II



**MARSHALLTOWN
MORE THAN EVER**

**Mike Ladehoff, Mayor
Carol Webb, City Administrator
24 North Center Street
Marshalltown, IA 50158
PH 641.754.5701 • FX 641.754.5717**

To: Mayor and City Council
From: Ben Daleske, Engineer
Meeting Date: May 11, 2026
Re: Resolution Approving Contract Change Order #2 for the 4th Street and Hughes Street Emergency Storm Sewer Repair Project, #SMW25001, an Increase of \$1,046.65

Strategic Plan Objective:

This work falls into City Strategy 3: Continually improve and sustain the City’s infrastructure, organization, and services.

Recommended:

Recommend approving Change Order #2 with Con-Struct for the 4th St. and Hughes St. Emergency Storm Sewer Repair project, SMW25001, in the amount of \$1,046.65.

Budget Impact:

This project is to be funded through a combination of storm water enterprise funds with negotiations underway with MetroNet for a portion of the costs associated with repairs to the damaged storm sewer. Within our CIP, we set aside \$50,000 annually for contractor assistance with emergency storm water infrastructure repairs that is cash-on-hand in the storm water enterprise fund. We have not expended any of those yet this FY. We also have sufficient 4th St & Meadow Lane Storm Sewer Project contingency funds from that project that was under budget and available in the Storm Water account

4th & Hughes Emergency Storm Sewer Repair Construction Costs:

Change Order #2 (Pending)	\$ 1,046.65	
Change Order #1	\$ 26,123.20	
Construction Base	\$ 81,420.00	Con-Struct
	\$ 108,589.85	TOTAL

Description/Background:

The initial change order covered additional pavement removal; however, field measurements later identified an extra 6.05 square yards that required removal and replacement.

Attachments:

1. 2026-05-11_2026-087_Resolution Approving CO2 - SMW25002
2. SMW25001 - Change Order 2_to Council

RESOLUTION APPROVING CONTRACT CHANGE ORDER #2 FOR THE 4TH ST & HUGHES ST EMERGENCY STORM SEWER REPAIR PROJECT, SMW25001, AN INCREASE OF \$1,046.65

WHEREAS, the City of Marshalltown, Iowa, has heretofore entered into a contract with Con-Struct, Inc. for the 4th St & Hughes St Emergency Storm Sewer Repair Project, #SMW25001; and

WHEREAS, a change that results in an increase is requested for items to complete the project.

NOW, THEREFORE, BE IT RESOLVED BY THE COUNCIL OF THE CITY OF MARSHALLTOWN, IOWA:

Section 1. That the contract Change Order #2 for the 4th St & Hughes St Emergency Storm Sewer Repair Project, #SMW25001, in the increased amount of \$1,046.65 is hereby accepted and approved.

Passed this 11th day of May 2026, and signed this ____ day of May 2026.

CITY OF MARSHALLTOWN, IOWA

Mike Ladehoff, Mayor

ATTEST:

Alicia Hunter, CMC, City Clerk

CONSTRUCTION CHANGE ORDER

Owner: City of Marshalltown
Project Number: SMW25001
Project Description: 4th St & Hughes St - Emergency Storm Sewer Repair Project

Change Order: #2
Change Order Recommended: 5/1/2026
Effective Date of Change Order: 5/4/2026

Date of Contract: November 4, 2025

Contractor: Con-Struct, Inc.
 Marshalltown, Iowa

Reason / Justification for Change Order:
 Additional Pavement was removed. These are the final measured quantities.

Awarded Contract Price	\$81,420.00	Original Substantial Completion Date:	12/13/2025
		Current Substantial Completion Date:	12/13/2025
<i>(insert change orders, as applicable)</i>		Proposed Substantial Completion Date:	4/30/2026
Change Order 1	\$ 26,123.20	Original Final Completion Date:	2/28/2026
		Current Final Completion Date:	6/30/2026
		Proposed Final Completion Date:	n/a
Total Current Contract Amount	\$107,543.20	Original Working Days:	n/a
		Current Working Days:	n/a
Proposed Work Changes (See Attached Tab)	\$1,046.65	Proposed Working Days:	n/a
Total Proposed Contract Amount	\$108,589.85		

Recommended by Engineer:



 Ben Daleske, PE
 City of Marshalltown

Civil Engineer II

 Title

5/6/26

 Date

Accepted by Contractor:



 Con-Struct, Inc.

Vice President

 Title

5/6/26

 Date

Authorized by Owner:

Title

Date

CONSTRUCTION CHANGE ORDER - TABULATION OF CHANGES

SMW25001

Change Order: #2

4th St & Hughes St - Emergency Storm Sewer Repair Project

Contract Quantities include quantities adjusted by **no** Change Orders

Bid Item Number	Item Description	(A)				(B) = (D) _{previous}		(C)		(D) = (B) + (C)	
		Original Contract				Previous Contract Adjustment		Proposed Contract Adjustment		Proposed Contract	
		Quantity	Unit	Unit Price	Value	Quantity	Value	Quantity	Value	Quantity	Value
1	SUBGRADE PREPARATION, 12 INCH	140.0	SY	\$5.00	\$700.00	178.4	\$892.00	6.05	\$ 30.25	184.45	\$922.25
2	SUBGRADE TREATMENT, MULTIAXIAL GEO-GRID	140.0	SY	\$5.00	\$700.00	178.4	\$892.00	6.05	\$ 30.25	184.45	\$922.25
3	SUBBASE, MODIFIED, 8 INCHES	140.0	SY	\$18.00	\$2,520.00	178.4	\$3,211.20	6.05	\$ 108.90	184.45	\$3,320.10
4	EXPLORATORY EXCAVATION	2.0	HR	\$600.00	\$1,200.00	2.0	\$1,200.00		\$ -	2.0	\$1,200.00
5	REPLACEMENT OF UNSUITABLE BACKFILL MATERIAL	100.0	CY	\$40.00	\$4,000.00	100.0	\$4,000.00		\$ -	100.0	\$4,000.00
6	REMOVAL OF SANITARY SEWER, 8"	20.0	LF	\$30.00	\$600.00	21.0	\$630.00		\$ -	21.0	\$630.00
7	SANITARY SEWER, PVC, 8"	20.0	LF	\$100.00	\$2,000.00	21.0	\$2,100.00		\$ -	21.0	\$2,100.00
8	SANITARY SEWER COUPLING	2.0	EA	\$300.00	\$600.00	2.0	\$600.00		\$ -	2.0	\$600.00
9	STORM SEWER, TRENCHED, RCP, 15 INCH	25.0	LF	\$150.00	\$3,750.00	41.0	\$6,150.00		\$ -	41.0	\$6,150.00
10	STORM SEWER, TRENCHED, RCP, 42 INCH	40.0	LF	\$350.00	\$14,000.00	40.0	\$14,000.00		\$ -	40.0	\$14,000.00
11	REMOVAL OF STORM SEWER, 36 INCH OR LESS	75.0	LF	\$30.00	\$2,250.00	60.0	\$1,800.00		\$ -	60.0	\$1,800.00
12	WATER MAIN, TRENCHED PVC, 6"	20.0	LF	\$150.00	\$3,000.00	18.0	\$2,700.00		\$ -	18.0	\$2,700.00
13	FITTING, DUCTILE IRON	4.0	EA	\$1,000.00	\$4,000.00	4.0	\$4,000.00		\$ -	4.0	\$4,000.00
14	COUPLING, DUCTILE IRON	1.0	EA	\$1,000.00	\$1,000.00	2.0	\$2,000.00		\$ -	2.0	\$2,000.00
15	WATER MAIN REMOVAL	20.0	LF	\$50.00	\$1,000.00	18.0	\$900.00		\$ -	18.0	\$900.00
16	INTAKE, SW-509	1.0	EA	\$12,000.00	\$12,000.00	1.0	\$12,000.00		\$ -	1.0	\$12,000.00
17	NEW CONNECTION TO EXISTING STRUCTURE	2.0	EA	\$2,500.00	\$5,000.00	2.0	\$5,000.00		\$ -	2.0	\$5,000.00
18	EX PIPE CONNECTION TO NEW STRUCTURE	2.0	EA	\$1,000.00	\$2,000.00	2.0	\$2,000.00		\$ -	2.0	\$2,000.00
19	REMOVE MANHOLE	1.0	EA	\$1,000.00	\$1,000.00	1.0	\$1,000.00		\$ -	1.0	\$1,000.00
20	PAVEMENT, PCC, 8 INCH, C4WRC20	140.0	SY	\$95.00	\$13,300.00	178.4	\$16,948.00	6.05	\$ 574.75	184.45	\$17,522.75
21	PAVEMENT REMOVAL	140.0	SY	\$20.00	\$2,800.00	178.4	\$3,568.00	6.05	\$ 121.00	184.45	\$3,689.00
22	MOBILIZATION	1.0	LS	\$4,000.00	\$4,000.00	1.0	\$4,000.00		\$ -	1.0	\$4,000.00
CO1-1	DEWATERING & SHORING	0.0	LS	\$10,800.00	\$0.00	1.0	\$10,800.00		\$ -	1.0	\$10,800.00
CO1-2	GRANULAR SURFACING INSTALL & REMOVE	0.0	SY	\$30.00	\$0.00	178.4	\$5,352.00	6.05	\$ 181.50	184.45	\$5,533.50
CO1-3	STORM SEWER, TRENCHED, RCP, 36" - CONNECTION	0.0	LS	\$1,800.00	\$0.00	1.0	\$1,800.00		\$ -	1.0	\$1,800.00
	TOTALS:				\$81,420.00		\$107,543.20		\$1,046.65		\$108,589.85



**MARSHALLTOWN
MORE THAN EVER**

**Mike Ladehoff, Mayor
Carol Webb, City Administrator
24 North Center Street
Marshalltown, IA 50158
PH 641.754.5701 • FX 641.754.5717**

To: Mayor and City Council
From: Ben Daleske, Engineer
Meeting Date: May 11, 2026
Re: Resolution Approving Engineer's Certificate of Completion and Accepting Con-Struct, Inc for 4th St & Hughes St - Emergency Storm Sewer Repair Project, #SMW25001

Strategic Plan Objective:

This work falls into City Strategy 3: Continually improve and sustain the City's infrastructure, organization, and services.

Recommended:

Staff recommends approval of final completion for the 4th St. & Hughes St. Emergency Storm Sewer Repair project and authorize release of retainage following 30 days of no claims following acceptance of completion.

Budget Impact:

This project is to be funded through a combination of storm water enterprise funds with negotiations underway with MetroNet for a portion of the costs associated with repairs to the damaged storm sewer. Within our CIP, we set aside \$50,000 annually for contractor assistance with emergency storm water infrastructure repairs that is cash-on-hand in the storm water enterprise fund. We have not expended any of those yet this FY. We also have sufficient 4th St & Meadow Lane Storm Sewer Project contingency funds from that project that was under budget and available in the Storm Water account.

4th & Hughes Emergency Storm Sewer Repair Construction Costs:

Change Order #2 (Pending)	\$ 1,046.65	
Change Order #1	\$ 26,123.20	
Construction Base	\$ 81,420.00	Con-Struct
	\$ 108,589.85	TOTAL

Description/Background:

The Contractor has completed all requirements of this construction contract, submitted necessary records, and the Engineer is recommending accepting this construction contract as complete.

The Contractor completed the project within the contract completion provisions.

The project completion dates are:

Substantial Completion: April 14, 2026

Engineer's Notice of Final Acceptance & Certificate of Completion: May 1, 2026

Council Approval of Completion: May 11, 2026

The substantial completion certificate indicates the date at which the project was sufficiently complete so that the work can be utilized for the purposes for which it was intended and also the date when the warranty/bond period begins. This was within the time of completion allowed by the construction contract, as amended. There is a 4-year warranty bond that is in effect until 4 years after project substantial completion (April 14, 2030).

With the Council's approval this evening of completion. Pending no claims, the city may release project retainage that was held after 30 days, but no later than 40 days from today's date.

Attachments:

1. 2026-05-11_2026-088_Resolution Approving Eng Certificate Completion 4th St and Hughes SMW25001
2. SMW25-001 SOSC and NOA

RESOLUTION APPROVING ENGINEER'S CERTIFICATE OF COMPLETION AND ACCEPTING CON-STRUCT, INC FOR THE 4TH ST AND HUGHES ST – EMERGENCY STORM SEWER REPAIR PROJECT #SMW25001

WHEREAS, the City of Marshalltown, Iowa has heretofore entered into a contract for labor and material for the 4th St & Hughes St - Emergency Storm Sewer Repair Project #SMW25001; and

WHEREAS, said project has been completed by Con-Struct, Inc, pursuant to the plans and specifications all as is set forth in the Final Acceptance and Certificate of Completion covering said project.

NOW, THEREFORE, BE IT RESOLVED BY THE COUNCIL OF THE CITY OF MARSHALLTOWN, IOWA;

Section 1. That the labor and material for the 4th St & Hughes St - Emergency Storm Sewer Repair Project, being project #SMW25001, is hereby accepted pursuant to the Engineer's Final Acceptance and Certificate of Completion and the City Clerk is hereby authorized and directed to do all things necessary to complete the contract with Con-Struct, Inc, including the payment of the items called for in said contract and Certificate of Completion.

Passed this 11th day of May 2026 and signed this _____ day of May 2026.

CITY OF MARSHALLTOWN, IOWA

Mike Ladehoff, Mayor

ATTEST:

Alicia Hunter, CMC, City Clerk

CERTIFICATE OF SUBSTANTIAL COMPLETION

Owner:	City of Marshalltown	Owner's Project No.:	SMW25-001
Construction Engineer:	City of Marshalltown	Engineer's Project No.:	SMW25-001
Contractor:	Con-Struct, Inc	Contractor's Project No.:	
Project:	2025 4 th St. & Hughes St. – Repair Project		
Contract Name:	2025 4 th St. & Hughes St. – Repair Project, SMW25-001 Plus Change Order #1 & 2		

This Preliminary Final Certificate of Substantial Completion applies to:

All Work The following specified portions of the Work:

All work as provided in the plans and as amended by change order.

Date of Substantial Completion: April 14, 2026

The Work to which this Certificate applies has been inspected by authorized representatives of Owner, Contractor, and Engineer, and found to be substantially complete. The Date of Substantial Completion of the Work or portion thereof designated above is hereby established, subject to the provisions of the Contract pertaining to Substantial Completion. The date of Substantial Completion in the final Certificate of Substantial Completion marks the commencement of the contractual correction period and applicable warranties required by the Contract.

A punch list of items to be completed or corrected is attached to this Certificate. This list may not be all-inclusive, and the failure to include any items on such list does not alter the responsibility of the Contractor to complete all Work in accordance with the Contract Documents.

Amendments of contractual responsibilities recorded in this Certificate should be the product of mutual agreement of Owner and Contractor; see Paragraph 15.03.D of the General Conditions.

The responsibilities between Owner and Contractor for security, operation, safety, maintenance, heat, utilities, insurance, and warranties upon Owner's use or occupancy of the Work must be as provided in the Contract, except as amended as follows:

Amendments to Owner's Responsibilities: None As follows:

None

Amendments to Contractor's Responsibilities: None As follows:

None

The following documents are attached to and made a part of this Certificate:

Notice of Acceptability

This Certificate does not constitute an acceptance of Work not in accordance with the Contract Documents, nor is it a release of Contractor's obligation to complete the Work in accordance with the Contract Documents.

Engineer



By (signature):

Name (printed):

Ben Daleske, P.E.

Title:

Civil Engineer II

NOTICE OF ACCEPTABILITY OF WORK

Owner:	City of Marshalltown	Owner's Project No.:	SMW25-001
Construction Engineer:	City of Marshalltown	Engineer's Project No.:	SMW25-001
Contractor:	Cedar Falls Construction Co. Inc	Contractor's Project No.:	
Project:	2025 PCC Patch Repair Project		
Contract Name:	2025 4 th St. & Hughes St. – Repair Project, SMW25-001 Plus Change Order #1 & 2		

Notice Date: May 1, 2026 Effective Date of the Construction Contract: November 3, 2025

The Engineer hereby gives notice to the Owner and Contractor that Engineer recommends final payment to Contractor, and that the Work furnished and performed by Contractor under the Construction Contract is acceptable, expressly subject to the provisions of the Construction Contract's Contract Documents ("Contract Documents"). This Notice of Acceptability of Work (Notice) is made expressly subject to the following terms and conditions to which all who receive and rely on said Notice agree:

This Notice has been prepared with the skill and care ordinarily used by members of the engineering profession practicing under similar conditions at the same time and in the same locality.

This Notice reflects and is an expression of the Engineer's professional opinion.

This Notice has been prepared to the best of Engineer's knowledge, information, and belief as of the Notice Date.

This Notice is based entirely on and expressly limited by the scope of services Engineer has been employed by Owner to perform or furnish during construction of the Project (including observation of the Contractor's Work) under the Owner-Engineer Agreement, and applies only to facts that are within Engineer's knowledge or could reasonably have been ascertained by Engineer as a result of carrying out the responsibilities specifically assigned to Engineer under such Owner-Engineer Agreement.

This Notice is not a guarantee or warranty of Contractor's performance under the Construction Contract, an acceptance of Work that is not in accordance with the Contract Documents, including but not limited to defective Work discovered after final inspection, nor an assumption of responsibility for any failure of Contractor to furnish and perform the Work thereunder in accordance with the Contract Documents, or to otherwise comply with the Contract Documents or the terms of any special guarantees specified therein.

This Notice does not relieve Contractor of any surviving obligations under the Construction Contract, and is subject to Owner's reservations of rights with respect to completion and final payment.

Engineer

By *(signature)*:  _____

Name *(printed)*: Ben Daleske, P.E.

Title: Civil Engineer II



**MARSHALLTOWN
MORE THAN EVER**

**Mike Ladehoff, Mayor
Carol Webb, City Administrator
24 North Center Street
Marshalltown, IA 50158
PH 641.754.5701 • FX 641.754.5717**

To: Mayor and City Council
From: Heather Thomas, Public Works Director
Meeting Date: May 11, 2026
Re: Resolution Approving Contract Change Order #14 for the East Main Street and Center Street Reconstruction Project, #STR22002, an Increase of \$3,454.47

Strategic Plan Objective:

One of the "High Priority" Goals established included, "Continue Implementing Downtown Master Plan".

Recommended:

Staff recommends approval of Change Order #14, an increase of \$3,454.47. This change order was necessary in the field due to locating a void under the sidewalk that was being removed to allow for an electrical connection. The void was caused by a collapsing private vault along 1st Ave in the street right-of-way.

Budget Impact:

The following numbers are shown as a FYI to understand project costs and where funding is coming from:

Expenses		
Design Engineering	\$ 751,938.00	<i>Bolton & Menk</i>
Smoke Blowing – Sewer Investigation	\$ 1,485.00	<i>CIT</i>
Construction - Base Bid	\$ 6,741,812.10	<i>Con-Struct Inc</i>
Construction Engineering	\$ 795,000.00	<i>Bolton & Menk</i>
Allowance – Vault/Stairwell Cost Share – 4 E Main St (<i>per City Council 08/11/25</i>)	\$ 25,000.00	<i>NTE Amount</i>
Allowance – Vault/Stairwell Cost Share – 16 E Main St (<i>per City Council 08/11/25</i>)	\$ 25,000.00	<i>NTE Amount - \$25,000.00 Reimbursed</i>

		<i>to Date</i>
REDUCED Allowance – Vault/Stairwell Cost Share – 24 E Main St (<i>per City Council 08/11/25</i>)	\$ 5,135.43	<i>\$5,135.43 Reimbursed to Date (reduced from NTE \$25k)</i>
Allowance – Vault/Stairwell Cost Share – 210 E Main St (<i>per City Council 08/11/25</i>)	\$ 25,000.00	<i>NTE Amount</i>
REDUCED Allowance – Vault/Stairwell Cost Share – 19 S Center St (<i>per City Council 08/11/25</i>)	\$ 561.63	<i>\$561.63 Reimbursed to Date (reduced from NTE \$25k)</i>
NEW Allowance – Vault/Stairwell Cost Share – 12 N 1 st Ave (<i>per City Council 08/11/25</i>)	\$ 5,000.00	<i>Estimated NTE this amount (reduced from \$25k)</i>
Allowance - Pedestrian & Business Traffic Control, Communication, & Signage	\$ 100,000.00	<i>Chamber & Others</i>
Estimate – Materials for City Staff performed Curb Appeal & Landscaping Improvements	\$ 20,000	<i>Various (spent \$237.41)</i>
Construction - Alt #1	\$ 337,535.50	<i>Con-Struct Inc</i>
Construction - Alt #2	\$ 46,347.00	<i>Con-Struct Inc</i>
Construction – Change Order #1	\$ 8,615.00	<i>Con-Struct Inc</i>
Construction – Change Order #2	\$ 12,880.00	<i>Con-Struct Inc</i>
Construction – Change Order #3	\$ 8,048.05	<i>Con-Struct Inc</i>
Construction – Change Order #4	\$ (34,498.00)	<i>Con-Struct Inc</i>
Construction – Change Order #5	\$ 37,363.00	<i>Con-Struct Inc</i>
Construction – Change Order #6	\$ 3,025.00	<i>Con-Struct Inc</i>

Construction – Change Order #7	\$ 7,500.00	<i>Con-Struct Inc</i>
Construction – Change Order #8	\$ 5,040.00	<i>Con-Struct Inc</i>
Construction – Change Order #9	\$ 0	<i>Con-Struct Inc</i>
Construction – Change Order #10	\$ 33,586.01	<i>Con-Struct Inc</i>
Construction – Change Order #11	\$ 5,775.00	<i>Con-Struct Inc</i>
Construction – Change Order #12	\$ (1,675.00)	<i>Con-Struct Inc</i>
Construction – Change Order #13	\$ (10,250.00)	<i>Con-Struct Inc</i>
Construction – Change Order #14	\$ 3,454.47	<i>Con-Struct Inc</i>
TOTAL	\$ 8,958,678.19	

Revenue		Notes on Payment Terms/Date Expected
METF Grant (Reallocate Sculpture Portion)	\$ 35,000.00	<i>Do JE in FY25 from State St Grant</i>
LOST (Downtown Site Furnishings)	\$ 45,490.00	<i>Reduced from \$85,490 to \$45,490 (01/29/26)</i>
Marshall Co (Design of Event Block)	\$ 34,000.00	<i>Rcvd FY24</i>
Fund 364 Original - Design Engineering	\$ 650,000.00	
Swap (Deduct 364)	\$ (319,712.29)	
Swap (Use 362)	\$ 319,712.29	
Fund 365 Original (Towards Const.)	\$ 7,146,000.00	
Swap (Increase 364)	\$ 307,938.00	
Swap (Deduct 365)	\$ (307,938.00)	
Deduct Alley Work	\$ (25,000.00)	<i>Estimated – will</i>

		<i>update once final quantities</i>
Marshall Co (50% of Event Block)	\$ 374,211.15	FY26 - \$158,578.88, FY27 - \$158,578.88, FY28 - \$57,053.39 +/- [Limit = \$475,736.63]
Marshalltown Water Works (MWW)	\$ 1,235,121.10	FY25 - \$250k, FY26 - \$500k, FY27 - \$250k, FY28 - \$235,121.10 +/-
MCSO - Construction - Alt #1	\$ 299,260.50	Payment Due w/ 30 Days of City Invoice; Responsible for Alt 1 Contingency
50% MCSO / 50% MWW - Construction - Alt #2	\$ 50,124.00	Payment Due w/ 30 Days of City Invoice; Responsible for Alt 2 Contingency
Marshalltown Water Works (MWW)	\$ 2,468.00	Estimated Change Order Responsibility
TOTAL	\$ 9,846,674.75	<i>*Note, contributions from MWW and County are estimates based on bid. These will be re-estimated at the conclusion of construction based on final quantities and changes throughout construction.</i>

Description/Background:

The E Main St and Center St Reconstruction project is a continuation of the Downtown Implementation Plan where five blocks will be receiving upgraded underground public utilities, new streets and sidewalks; streetscape elements along the route; and an event plaza north of the Courthouse.

This change order accounts for changes along 1st Ave, associated with a void discovered under the sidewalk in front of 12 N 1st Ave when electrical was being routed to the meter. Upon further investigation, it was determined that there was a vault on that building that had started to collapse and cave-in. The city worked with the property owner to address the vault. The property owner hired a mason to block & apply water resistant membrane in their wooden doorway opening to the vault, which the city administrator has agreed to the 50% reimbursement allowance towards their expenses; and the city had Con-Struct conduct the excavation to open the area up and fill the former vault from the outside. There will also be a small overrun on sidewalk as the sidewalk removal/replacement limits will increase to accommodate this work. Overall, we thank the property owner, B Plus Properties; the property owner’s contractor, Ciro Dilorio Masonry, and our contractor, Con-Struct for working through this unknown during construction.

The current project completion dates for this project are as follows.

Phase	Substantial Completion	Final Completion
Phase 1 – Center St (Stage A - Center/Main Intersection and Center St from Main to Church)	September 6, 2025	December 30, 2026
Phase 1 – Center St (Stage B - Center St from Main to State)	September 22, 2025	December 30, 2026
Phase 2 – Main St from Center to 1 st Ave	January 5, 2026	December 30, 2026
Phase 3.1 – Main St / 1 st Ave Intersection	60 Calendar Days in 2026 * (target by May 27, 2026)	December 30, 2026
Event Plaza Space	(estimated mid-June 2026) **	
Phase 3.2 – Main St from 1 st Ave to 3 rd Ave	December 11, 2026	December 30, 2026
Bid Alternate 1 & 2 – Parking Lot & Alley	45 Calendar Days (June 12th, 2025 – July 27, 2025)	December 30, 2026

**During work along 1st Ave, two vaults that were not anticipated to be included in the project or impacted / in conflict with the proposed project were determined to be. While some of that work was contracted directly by property owners, some of this will result in extra work by our Contractor, and additional time delay – which will be entitled to an extension.*

***During work on the event plaza space, the Contractor encountered delay on the product that was specified for the structural soil for the trees. The product specified only has one supplier in Iowa and was unable to provide the specified soil at the correct moisture conditions due to the wet spring conditions. While alternative out of state sources and other urban tree options were evaluated, it was determined that allowing the Iowa source to dry-out their soil was the best path forward;*

however, it did delay the Contractor from being able to continue work in that space.

Design and Construction Engineering services for the base bid of this project are being handled by Bolton & Menk with the alternates provided by CGA.

Attachments:

1. 2026-05-11_2026-089_Resolution Approving CO14 East Main-Center St Reconstruction STR22002
2. STR22002 E Main St - Change Order 14_to Council

RESOLUTION APPROVING CONTRACT CHANGE ORDER #14 FOR THE EAST MAIN STREET AND CENTER STREET RECONSTRUCTION PROJECT, #STR22002, AN INCREASE OF \$3,454.47

WHEREAS, the City of Marshalltown, Iowa, has heretofore entered into a contract with Con-Struct, Inc. for the East Main Street and Center Street Reconstruction #STR22002; and

WHEREAS, a change that results in an increase is requested for items to complete the project.

NOW, THEREFORE, BE IT RESOLVED BY THE COUNCIL OF THE CITY OF MARSHALLTOWN, IOWA:

Section 1. That the contract Change Order #14 for the East Main Street and Center Street Reconstruction Project #STR22002, in the increased amount of \$3,454.47 is hereby accepted and approved.

Passed this 11th day of May 2026, and signed this _____ day of May 2026.

CITY OF MARSHALLTOWN, IOWA

Mike Ladehoff, Mayor

ATTEST:

Alicia Hunter, CMC, City Clerk



Bolton & Menk

Change Order Details

Marshalltown - East Main St.

Description	East Main Street from Center to 3rd Ave and Center Street from State Street to Church Street. Full Reconstruction
Prime Contractor	CON-STRUCT, INC.
Change Order	14
Status	Pending
Date Created	05/04/2026
Type	Local Funding
Summary	Change Order 14: 12 N 1st Ave Vault
Change Order Description	Change Order 14 accounts for a vault found underneath the sidewalk in front of 12 N 1st Ave (Beatrice African Business Center) during the N 1st Ave sidewalk work. The business owner will pay for the block-in and waterproofing materials. Items covered by Change Order 14 will include the sidewalk/vault top removal, fill material to fill the opening and under the sidewalk, and the pavement being put back.
Awarded Project Amount	\$7,125,694.60
Authorized Project Amount	\$7,201,103.66
Change Order Amount	\$3,454.47
Revised Project Amount	\$7,204,558.13

New Items

Line Number	Item ID	Unit	Quantity	Unit Price	Extension
Section: 1 - Description					
1250	0000-999-J	LS	1.000	\$1,830.000	\$1,830.00
'LUMP SUM' ITEM: 12 N 1st Ave Vault Equipment					
Reason: Equipment committed to addressing the 12 N 1st Ave (Beatrice) vault.					
Funding Details					
		CITY	1.000	\$1,830.000	\$1,830.00
1260	0000-999-G	HR	9.000	\$80.000	\$720.00
'HOURS' ITEM: 12 N 1st Ave Vault Labor					
Reason: Labor committed to addressing the 12 N 1st Ave (Beatrice) vault.					
Funding Details					
		CITY	9.000	\$80.000	\$720.00
1270	0000-999-J	LS	1.000	\$904.470	\$904.47
'LUMP SUM' ITEM: 12 N 1st Ave Vault Materials					
Reason: Material committed to addressing the 12 N 1st Ave (Beatrice) vault.					
Funding Details					
		CITY	1.000	\$904.470	\$904.47
3 items					Total: \$3,454.47

Funding Summary

Fund Package	Original Amount	Authorized Amount	Pending Change	Revised Amount
CITY	\$5,715,250.10	\$5,828,489.16	\$3,454.47	\$5,831,943.63
MARSHALLTOWN WATER WORKS	\$1,026,562.00	\$1,015,730.00	\$0.00	\$1,015,730.00
MCSO BID ALT 1	\$337,535.50	\$305,760.50	\$0.00	\$305,760.50
MCSO BID ALT 2	\$46,347.00	\$51,124.00	\$0.00	\$51,124.00
4 fund packages	\$7,125,694.60	\$7,201,103.66	\$3,454.47	\$7,204,558.13

Attachments

Document	Name	Description	Submission Date
2026.05.04_-_Construct_Invoice.pdf	2026.05.04 - Con-Struct Invoice.pdf		05/06/2026 01:03 AM CDT
1 attachment			

Signatures

Agreed -  Date: 5/6/26
Contractor

Recommended - Gregory Brownard Date: 5/7/2026
Project Engineer

Approved - _____ Date: _____
City



**MARSHALLTOWN
MORE THAN EVER**

**Mike Ladehoff, Mayor
Carol Webb, City Administrator
24 North Center Street
Marshalltown, IA 50158
PH 641.754.5701 • FX 641.754.5717**

To: Mayor and City Council
From: Heather Thomas, Public Works Director
Meeting Date: May 11, 2026
Re: Resolution Ordering Construction of the 2026 Street Rehabilitation Project_HMA, #STR26002, Setting Public Hearing on Proposed Plans, Specifications, Form of Contract and Opinion of Probable Cost and Directing Publication of Notice to Bidders

Strategic Plan Objective:

Continually improve and sustain the City's infrastructure, organization, and services.

Recommended:

Staff recommends ordering construction and setting the public hearing.

Budget Impact:

The opinion of probable construction costs is \$2,408,024. Funding is budgeted for and available within the Street Improvement Program funds, which are a combination of GO Bond funds and Road Use Tax.

Description/Background:

In late 2025, city staff reviewed pavement condition data collected through the Iowa Pavement Management Program to identify potential street rehabilitation projects. City staff also requested statement of qualifications for consulting firms to assist City staff with Pavement Management that also had a wide range of Pavement Treatment Design experience. HR Green was selected as the most qualified.

Since that time, city staff have pulled together available records on those street rehabilitation projects; coordinated and revised potential project locations based on other work and minimize impacts for projects during the 2026 construction season; reviewed potential projects in the near future (<5 yr) that may impact these streets; conducted field review with representatives of HR Green; completed select coring of the streets; and eliminated certain streets that data/coring caused above average concern. HR Green completed the design for the selected street segments in partnership with city staff and it is ready to go out to bid. There will be some sidewalk needs at the intersections of select streets included in this project that will follow and be bid separately.

We proposed calendar dates for completion with substantial completion on or before October 30, 2026 and full completion on or before April 30th, 2027.

Liquidated damages have been set at \$500 / calendar day for completion.

The bid timeline is as follows:

- Ordering construction at the May 11th, 2026 council meeting
- Public Hearing at the May 26th, 2026 council meeting (Note Tuesday Mtg)
- Receiving/Opening Bids at 10:00 AM, Tuesday, June 2nd, 2026 @ City Hall
- Awarding Bid at the June 8th, 2026 council meeting

Attachments:

1. 2026-05-11_2026-090_Resolution Order Construction STR26002_2026 Street Rehabilitation Project_HMA
2. STR26002_2026 Street Rehabilitation Project_HMA_Notice
3. STR26002_2026 Street Rehabilitation Project_HMA_ProjectManual
4. STR26002_2026 Street Rehabilitation Project_HMA_Plans
5. STR26002_2026 Street Rehabilitation Project_HMA_OPC

**RESOLUTION ORDERING CONSTRUCTION OF THE 2026 STREET
REHABILITATION PROJECT - HMA, #STR26002, SETTING PUBLIC HEARING ON
PROPOSED PLANS, SPECIFICATIONS, FORM OF CONTRACT AND OPINION OF
PROBABLE COST AND DIRECTING PUBLICATION OF NOTICE TO BIDDERS**

WHEREAS, there is now on file in the office of the City Clerk proposed plans, specifications, form of contract, and opinion of probable costs for the 2026 Street Rehabilitation Project - HMA, in the City of Marshalltown, Iowa, as is fully set forth in the plans and specifications for Project No STR26002; and

WHEREAS, the cost of the said improvement is in excess of \$25,000 and a public hearing on the plans, specifications, form of contract and the opinion of probable cost of said improvement is required by law and that notice thereof shall be given as required by law; and

WHEREAS, it is intended that the cost of said improvement shall be paid from such funds as the City may legally use for such purposes or from the proceeds from the issuance of such bonds as may be legally issued for said purposes or any combination of the above methods of financing.

NOW, THEREFORE, BE IT RESOLVED BY THE COUNCIL OF THE CITY OF MARSHALLTOWN, IOWA:

Section 1. This Council does hereby order the construction of the 2026 Street Rehabilitation Project - HMA in the City of Marshalltown, Iowa, which public improvement is fully and particularly described in the plans and specifications for Project No. STR26002, now on file in the office of the City Clerk of Marshalltown, Iowa.

Section 2. That the method of construction shall be by contract in accordance with the plans and specifications and general stipulations for the said improvement approved by the City Council.

Section 3. The Contractor will be paid in monthly estimates for work completed as set out in the specifications. The project shall begin on or near the appropriate starting date as specified on the form of proposal and shall be completed within the specified number of calendar days also indicated thereon.

Section 4. That the said improvements shall be paid for from such funds of the City as may be legally used for such purposes, or from the proceeds of the issuance of such bonds as may be legally issued for such purposes or from any combination of such methods of financing and will be paid in accordance with the Notice to Bidders duly published in connection therewith. The Finance Director shall establish on the books a 2026 Street Rehabilitation Project - HMA fund and the bond proceeds or such funds of the City as may be legally used for such purposes are hereby appropriated to pay all costs of the improvements including legal publication, bond, design, engineering, survey and inspection, contract and contingency cost as estimated by the Engineer. The Finance Director is directed to advance all sums necessary from the project fund, and to set up on the books the obligations and receivables of the fund.

Section 5. The City Clerk is hereby directed to publish notice of hearing on plans, specifications, and form of contract and opinion of probable cost in the manner provided by law for the public improvement outlined herein and that any person interested therein may appear and make objections thereto, if any he has. This Council will meet in the Council Chamber, Second Floor, 10 West State Street at Marshalltown, Iowa, at 5:30 P.M., local time on May 26, 2026, for the purpose of hearing all of said objections so made and for taking final action upon the plans, specifications, and form of contract now on file.

Section 6. Staff is further directed to advertise for bids in the manner provided by law for the construction of said improvements, setting forth in said notice such necessary pertinent information as will advise prospective bidders thereof together with the proposed manner of payment of the work to be constructed and that such bids be filed and received in the office of the City Clerk of Marshalltown, Iowa, up to 10:00 A.M., local time, on June 2, 2026. The bids will be opened, read, and tabulated by the Public Works Director or their designate at that time and will be acted upon by the City Council of said City at a meeting to be held in the Council Chambers, Second Floor, 10 West State Street, Marshalltown, Iowa, at 5:30 P.M., local time, on June 8, 2025, or at such later time and place as may then be fixed for considering such bids as shall be filed in connection with the improvement herein ordered and in compliance with the notice of taking bids therein, hereby ordered to be published.

Passed this 11th day of May 2026, and signed this _____ day of May 2026.

CITY OF MARSHALLTOWN, IOWA

Mike Ladehoff, Mayor

ATTEST:

Alicia Hunter, CMC, City Clerk

OFFICIAL NOTICE OF HEARING AND LETTING

CITY OF MARSHALLTOWN

MARSHALLTOWN, IOWA

2026 STREET REHABILITATION PROJECT_HMA

PROJECT NO. STR26002

NOTICE OF PUBLIC HEARING ON PROPOSED PLANS, SPECIFICATIONS, PROPOSED FORM OF CONTRACT AND OPINION OF PROBABLE COST FOR THE 2026 STREET REHABILITATION PROJECT_HMA IN THE CITY OF MARSHALLTOWN, IOWA, AND THE TAKING OF BIDS FOR SUCH IMPROVEMENTS.

A public hearing will be held at 5:30 p.m. local time on the 26th day of May, 2026 in the Council Chambers, Second Floor, 10 West State Street, Marshalltown, Iowa, on the proposed plans, specifications, proposed form of contract, and the opinion of probable cost of improvements proposed to be constructed under PROJECT NO. STR26002, the 2026 STREET REHABILITATION PROJECT_HMA, which is now on file in the office of the City Clerk and at said hearing any interested person may appear and file objection thereto or to the bidding process.

Sealed proposals based upon the proposed plans, specifications, proposed form of contract, opinion of probable costs of improvement, will be received at the City Clerk's Office located at 24 N. Center Street, Marshalltown, IA until 10:00 a.m. local time, on the 2nd Day of June, 2026 for the construction of the 2026 STREET REHABILITATION PROJECT_HMA as described in the plans and specifications for Project No. STR26002, and which will be opened, read, and tabulated by the City Engineer or her designate at that time, will be acted upon by the City Council of said City at a meeting to be held in the Council Chambers on the 8th day of June, 2026 or at such later time and place as may then be fixed.

The proposed work will involve furnishing the labor, equipment, and materials necessary for constructing the 2026 STREET REHABILITATION PROJECT_HMA in Marshalltown, Iowa as shown in the plans and specifications for PROJECT NO. STR26002, the 2026 STREET REHABILITATION PROJECT_HMA.

The estimated quantities of materials and labor to be furnished in the construction of said improvements and on which bids will be received are as follows:

This project includes approximately 48,000 SY of milling, 10,000 tons of asphalt overlay including interlayer base, pavement patching, curb and gutter repairs, and related work on approximately 3.3 miles of existing streets. Specific project locations along with the kind and approximate quantity of materials to be used shall be as set forth in the Plans and Specifications.

All work is to be done in strict compliance with the Plans and Specifications for said PROJECT NO. STR26002 as proposed by the City Engineer.

Base Bid: All work shall be substantially complete on or before October 30, 2026 and shall be completed and ready for final payment on or before April 30, 2027.

Obtaining the Bidding Documents

Copies of the Plans and Specifications for this project may be obtained from HR Green, Inc., 8710 Earhart Lane SW, Cedar Rapids, IA 52404, Ph: 319-841-4000 or e-mail request to kellijo.ernst@hrgreen.com; or plans, specifications and proposed contract documents may be examined at the office of the City Engineer, Marshalltown, Iowa, and at the office of the City Clerk, Marshalltown, Iowa. Bidding Documents may be downloaded from the City of Marshalltown’s web site upon registration at no cost. The documents may be downloaded at <https://www.marshalltown-ia.gov/Bids.aspx>.

A deposit of \$150 per paper set of plans, specifications and proposed contract documents will be charged, all of which will be refunded if the paper documents are returned in reusable condition within 14 days of the Award of Contract. If all paper documents are not returned in reusable condition and within 14 days, the deposit will be forfeited.

Pre-bid Conference

A pre-bid conference will not be held for the Project.

Instructions to Bidders.

A Bid must be accompanied by Bid security made payable to Owner in an amount of five (5) percent of Bidder’s maximum Bid price (determined by adding the base bid and all alternates) and in the form of a Bid bond issued by a surety meeting the requirements of the General Conditions or a certified check in an amount equal to five percent (5%) of the total amount of the bid, drawn on and certified payable by a solvent bank to the City Treasurer of the City. Such Bid bond will be issued in the form included in the Bidding Documents.

For all further requirements regarding bid submittal, qualifications, procedures, and contract award, refer to the Instructions to Bidders that are included in the Bidding Documents.

The City Council reserves the right to reject any and all bids and to waive technicalities and irregularities and all bids must remain effective for a period of 30 days of opening same.

This Notice to Bidders is hereby published by authority of resolution duly adopted by the Council of the City of Marshalltown on the _____ day of _____, 2026.

Owner: _____
City of Marshalltown

By: _____
Alicia Hunter

Title: _____
City Clerk

Specification No. _____

**SPECIFICATIONS
FOR
2026 MARSHALLTOWN STREET REHABILITATION PROJECT
CITY OF MARSHALLTOWN
2026**

**HR Green, Inc.
Project No. 2602496
City Project No. STR26002**

OWNERSHIP OF DOCUMENT

This document, and the ideas and designs incorporated herein, as an instrument of professional service, is the property of HR Green, Inc. and is not to be used, in whole or in part, for any other project without the written authorization of HR Green, Inc.

HR Green, Inc.
Project No. 2602496
City Project No. STR26002

2026 Marshalltown Street Rehabilitation Project
Marshalltown, IA

	<p>I hereby certify that this engineering document was prepared by me or under my direct personal supervision and that I am a duly licensed Professional Engineer under the laws of the State of Iowa.</p> <p><u>Caleb Jansen</u> Date: <u>05/04/2026</u></p> <p>CALEB P. JANSEN, P.E.</p> <p>License No. 28973</p> <p>My renewal date is December 31, 2027.</p> <p>Pages or sheets covered by this seal: The entire Project Manual</p>
---	---

HR Green, Inc.
Project No. 2602496
City Project No. STR26002

2026 Marshalltown Street Rehabilitation Project
Marshalltown, IA

**SPECIFICATIONS
FOR
2026 MARSHALLTOWN STREET REHABILITATION PROJECT
MARSHALLTOWN, IA**

TABLE OF CONTENTS

GENERAL REQUIREMENTS OF THE CONTRACT

NOTICE OF PUBLIC HEARING
NOTICE TO BIDDERS
INSTRUCTIONS TO BIDDERS
PROPOSAL
BID BOND
CONTRACT
PERFORMANCE, PAYMENT AND MAINTENANCE BOND

SPECIAL PROVISIONS

This project is based on 2026 Edition of
The SUDAS Standard Specifications
unless modified herein

OFFICIAL NOTICE OF HEARING AND LETTING

CITY OF MARSHALLTOWN

MARSHALLTOWN, IOWA

2026 STREET REHABILITATION PROJECT_HMA

PROJECT NO. STR26002

NOTICE OF PUBLIC HEARING ON PROPOSED PLANS, SPECIFICATIONS, PROPOSED FORM OF CONTRACT AND OPINION OF PROBABLE COST FOR THE 2026 STREET REHABILITATION PROJECT_HMA IN THE CITY OF MARSHALLTOWN, IOWA, AND THE TAKING OF BIDS FOR SUCH IMPROVEMENTS.

A public hearing will be held at 5:30 p.m. local time on the 26th day of May, 2026 in the Council Chambers, Second Floor, 10 West State Street, Marshalltown, Iowa, on the proposed plans, specifications, proposed form of contract, and the opinion of probable cost of improvements proposed to be constructed under PROJECT NO. STR26002, the 2026 STREET REHABILITATION PROJECT_HMA, which is now on file in the office of the City Clerk and at said hearing any interested person may appear and file objection thereto or to the bidding process.

Sealed proposals based upon the proposed plans, specifications, proposed form of contract, opinion of probable costs of improvement, will be received at the City Clerk's Office located at 24 N. Center Street, Marshalltown, IA until 10:00 a.m. local time, on the 2nd Day of June, 2026 for the construction of the 2026 STREET REHABILITATION PROJECT_HMA as described in the plans and specifications for Project No. STR26002, and which will be opened, read, and tabulated by the City Engineer or her designate at that time, will be acted upon by the City Council of said City at a meeting to be held in the Council Chambers on the 8th day of June, 2026 or at such later time and place as may then be fixed.

The proposed work will involve furnishing the labor, equipment, and materials necessary for constructing the 2026 STREET REHABILITATION PROJECT_HMA in Marshalltown, Iowa as shown in the plans and specifications for PROJECT NO. STR26002, the 2026 STREET REHABILITATION PROJECT_HMA.

The estimated quantities of materials and labor to be furnished in the construction of said improvements and on which bids will be received are as follows:

This project includes approximately 48,000 SY of milling, 10,000 tons of asphalt overlay including interlayer base, pavement patching, curb and gutter repairs, and related work on approximately 3.3 miles of existing streets. Specific project locations along with the kind and approximate quantity of materials to be used shall be as set forth in the Plans and Specifications.

All work is to be done in strict compliance with the Plans and Specifications for said PROJECT NO. STR26002 as proposed by the City Engineer.

Base Bid: All work shall be substantially complete on or before October 30, 2026 and shall be completed and ready for final payment on or before April 30, 2027.

Obtaining the Bidding Documents

Copies of the Plans and Specifications for this project may be obtained from HR Green, Inc., 8710 Earhart Lane SW, Cedar Rapids, IA 52404, Ph: 319-841-4000 or e-mail request to kellijo.ernst@hrgreen.com; or plans, specifications and proposed contract documents may be examined at the office of the City Engineer, Marshalltown, Iowa, and at the office of the City Clerk, Marshalltown, Iowa. Bidding Documents may be downloaded from the City of Marshalltown’s web site upon registration at no cost. The documents may be downloaded at <https://www.marshalltown-ia.gov/Bids.aspx>.

A deposit of \$150 per paper set of plans, specifications and proposed contract documents will be charged, all of which will be refunded if the paper documents are returned in reusable condition within 14 days of the Award of Contract. If all paper documents are not returned in reusable condition and within 14 days, the deposit will be forfeited.

Pre-bid Conference

A pre-bid conference will not be held for the Project.

Instructions to Bidders.

A Bid must be accompanied by Bid security made payable to Owner in an amount of five (5) percent of Bidder’s maximum Bid price (determined by adding the base bid and all alternates) and in the form of a Bid bond issued by a surety meeting the requirements of the General Conditions or a certified check in an amount equal to five percent (5%) of the total amount of the bid, drawn on and certified payable by a solvent bank to the City Treasurer of the City. Such Bid bond will be issued in the form included in the Bidding Documents.

For all further requirements regarding bid submittal, qualifications, procedures, and contract award, refer to the Instructions to Bidders that are included in the Bidding Documents.

The City Council reserves the right to reject any and all bids and to waive technicalities and irregularities and all bids must remain effective for a period of 30 days of opening same.

This Notice to Bidders is hereby published by authority of resolution duly adopted by the Council of the City of Marshalltown on the _____ day of _____, 2026.

Owner: _____
City of Marshalltown

By: _____
Alicia Hunter

Title: _____
City Clerk

NOTICE TO BIDDERS
2026 MARSHALLTOWN STREET REHABILITATION PROJECT
MARSHALLTOWN, IA

Time and Place for Filing Sealed Proposals. Sealed bids for the work comprising the improvement as stated below must be filed before 10:00 AM on June 2, 2026 in the office of the City Clerk, Marshalltown City Hall, 24 North Center Street, Marshalltown, IA 50158.

Time and Place Sealed Proposals Will be Opened and Considered. Sealed proposals will be opened and bids tabulated at 10:00 AM on June 2, 2026 in the office of City Clerk, Marshalltown City Hall, 24 North Center Street, Marshalltown, IA 50158 for consideration by the City Council of City of Marshalltown at its meeting on June 8, 2026 at 5:30 PM. The City of Marshalltown reserves the right to reject any and all bids.

The City of Marshalltown, in accordance with Title VI of the Civil Rights Act of 1964, 78 Stat. 252, 42U.S.C. 2000d to 2000d-4 and Title 49, Code of Federal Regulations, Department of Transportation, Subtitle A, Office of the Secretary, Part 21, Nondiscrimination in Federally-assisted programs of the Department of Transportation issued pursuant to such Act, hereby notifies all bidders that it will affirmatively ensure that in any contract entered into pursuant to this advertisement, minority business enterprises will be afforded full opportunity to submit bids in response to this invitation and will not be discriminated against on the grounds of race, color, or national origin in consideration for an award.

Time for Commencement and Completion of Work. Notice to Proceed shall be no later than Within 10 days of Execution of Agreement, work shall be substantially complete on or before October 30, 2026, and shall be fully completed on or before April 30, 2027. Damages in the amount of Five Hundred & 00/100 Dollars (\$500.00) per day will be assessed for each day the work remains incomplete.

Bid Security. Each bidder shall accompany its bid with bid security, as defined in Section 26.8 of the Iowa Code made payable to Owner in an amount of five (5) percent of Bidder's maximum Bid price (determined by adding the base bid and all alternates) and in the form of a Bid bond issued by a surety meeting the requirements of the General Conditions or a certified check in an amount equal to five percent (5%) of the total amount of the bid, drawn on and certified payable by a solvent bank to the City Treasurer of the City. Such Bid bond will be issued in the form included in the Bidding Documents.

Contract Documents. Copies of the Plans and Specifications for this project may be obtained from HR Green, Inc., 8710 Earhart Lane SW, Cedar Rapids, IA 52404, Ph: 319-841-4000 or e-mail request to kellijo.ernst@hrgreen.com; or plans, specifications and proposed contract documents may be examined at the office of the City Engineer, Marshalltown, Iowa, and at the office of the City Clerk, Marshalltown, Iowa. Bidding Documents may be downloaded from the City of Marshalltown's web site upon registration at no cost. The documents may be downloaded at <https://www.marshalltown-ia.gov/Bids.aspx>.

A deposit of \$150 per paper set of plans, specifications and proposed contract documents will be charged, all of which will be refunded if the paper documents are returned in reusable condition within 14 days of the Award of Contract. If all paper documents are not returned in reusable condition and within 14 days, the deposit will be forfeited.

Public Hearing on Proposed Contract Documents and Estimated Costs for Improvement. A public hearing will be held by the City Council of the City of Marshalltown on the proposed contract documents (plans, specifications and form of contract) and estimated cost for the improvement at its meeting at 5:30 PM on May 26, 2026 in the Marshalltown City Hall, 24 North Center Street, Marshalltown, IA 50158.

HR Green, Inc.
Project No. 2602496
City Project No. STR26002

2026 Marshalltown Street Rehabilitation Project
Marshalltown, IA

Preference of Products and Labor. Preference shall be given to domestic construction materials by the contractor, subcontractors, material, men, and suppliers in performance of the contract and, further, by virtue of statutory authority, preference will be given to products and provisions grown and coal produced within the State of Iowa, and to Iowa domestic labor, to the extent lawfully required under Iowa statutes.

Sales Tax Exemption Certificates. The bidder shall not include sales tax in the bid. The City of Marshalltown will distribute tax exemption certificates and authorization letters to the Contractor and all subcontractors who are identified. The Contractor and subcontractor may make copies of the tax exemption certificates and provide a copy to each supplier providing construction materials. These tax exemption certificates and authorization letters are applicable only for this specific project under the Contract.

General Nature of Public Improvement. This project includes approximately 48,000 SY of milling, 10,000 tons of asphalt overlay including interlayer base, pavement patching, curb and gutter repairs, and related work on approximately 3.3 miles of existing streets. Specific project locations along with the kind and approximate quantity of materials to be used shall be as set forth in the Plans and Specifications.

The Bidder is required to submit prices for all items in the Base Bid and Add Alternates. The contract shall be awarded based on the base bid amount. The City of Marshalltown reserves the right to not proceed with any Add Alternate items or proceed with any combination of Add Alternate items.

This Notice is given by authority of the City of Marshalltown

Alicia Hunter, City Clerk
City of Marshalltown

INSTRUCTIONS TO BIDDERS
2026 MARSHALLTOWN STREET REHABILITATION PROJECT
MARSHALLTOWN, IA

The work comprising the above referenced project shall be constructed in accordance with the 2026 Edition of the SUDAS Standard Specifications Manual. The terms used in the contract version of the documents are defined in said Standard Specifications. Before submitting your bid, please review the requirements of Division One, General Provisions and Covenants. Please be certain that all documents have been completed properly, as failure to complete and sign all documents and to comply with the requirements listed below can cause your bid not to be read.

I. BID SECURITY

- A. The bid security must be in the minimum amount of Five (5) percent of the total bid amount including all add alternates (do not deduct the amount of deduct alternates). Bid security shall be in the form of a cashier's check, a certified check, or a bank money order drawn on a FDIC insured bank in Iowa or drawn on a FDIC insured bank chartered under the laws of the United States; or a certified share draft drawn on a credit union in Iowa or chartered under the laws of the United States; or a bid bond executed by a corporation authorized to contract as a surety in Iowa or satisfactory to the Jurisdiction.
- B. The bid bond must be submitted on the SUDAS Bid Bond form as no other bid bond forms are acceptable. All signatures on the bid bond must be original signatures in ink; facsimile (fax) of any signature on the bid bond is not acceptable.
- C. Bid security other than said bid bond shall be in accordance with Chapter 26 of the Iowa Code.

II. SUBMISSION OF THE PROPOSAL AND IDENTITY OF BIDDER

- A. The proposal shall be sealed in an envelope, properly identified as the Proposal with the project title and the name and address of the bidder, and deposited with the Jurisdiction at or before the time and at the place provided in the Notice to Bidders. It is the sole responsibility of the bidder to see that its proposal is delivered to the Jurisdiction prior to the time for opening bids, along with the appropriate bid security sealed in the separate envelope identified as Bid Security and attached to the outside of the bid proposal envelope. Any proposal received after the scheduled time for the receiving of proposals will be returned to the bidder unopened and will not be considered.
- B. The Bidder Status Form is required by the Iowa Labor Commissioner, pursuant to Iowa Administrative Code rule 875-156.2(1). The bidder must complete the form and submit it with the proposal. Failure to provide the Bidder Status Form with the bid may result in the bid being deemed non-responsive and may result in the bid being rejected. If the bidder does not qualify as a resident bidder, the nonresident bidder shall specify on the Bidder Status Form whether any preference to resident bidders, including but not limited to any preference to bidders, the imposition of any type of labor force preference, or any other form of preferential treatment to bidders or laborers from that state or foreign country is in effect in the nonresident bidder's state or country of domicile at the time of a bid submittal. Application of the preference against a non-resident bidder shall be in accordance with the information filed with the Proposal on the Bidder Status Form.

C. The following documents shall be completed, signed and returned in the Proposal envelope. The bid cannot be read if any of these documents are omitted from the Proposal envelope.

1. PROPOSAL – Complete each of the following parts:

- Part B – Acknowledgment of Addenda, if any have been issued;
- Part C – Bid Items, Quantities and Prices;
- Part F – Additional Requirements;
- Part G – Identity of Bidder;

The following documents which are proposal attachments must be completed and attached:

ITEM NO.	DESCRIPTION OF ATTACHMENT
-----------------	----------------------------------

- | | |
|----|--|
| 1. | Bid Bond |
| 2. | Bidder Status Form and Worksheet: Authorization to Transact Business |

Sign the proposal; and have the signature notarized. The signature on the proposal and all proposal attachments must be an original signature in ink signed by the same individual who is the Company Owner or an authorized Officer of the Company; copies or facsimile of any signature will not be accepted.

The following documents must be submitted as printed. No alterations, additions, or deletions are permitted. If the Bidder notes a requirement in the contract documents which the Bidder believes will require a conditioned or unsolicited alternate bid, the Bidder must immediately notify the Jurisdictional Engineer in writing. The Jurisdictional Engineer will issue any necessary interpretation by an addendum.

PROPOSAL
2026 MARSHALLTOWN STREET REHABILITATION PROJECT
MARSHALLTOWN, IA

PROPOSAL: PART A – SCOPE

The City of Marshalltown, hereinafter called the “Jurisdiction”, has need of a qualified contractor to complete the work comprising the below referenced improvement. The undersigned Bidder hereby proposes to complete the work comprising the below referenced improvement as specified in the contract documents, which are officially on file with the Jurisdiction, in the office of the City Clerk at the prices hereinafter provided in Part C of the Proposal, for the following described improvements:

This project includes approximately 48,000 SY of milling, 10,000 tons of asphalt overlay including interlayer base, pavement patching, curb and gutter repairs, and related work on approximately 3.3 miles of existing streets. Specific project locations along with the kind and approximate quantity of materials to be used shall be as set forth in the Plans and Specifications.

The bidder is required to submit prices for all items in the Base Bid and Add Alternates. The contract shall be awarded based on the Base Bid amount. The City of Marshalltown reserves the right to not proceed with any Add Alternate items or proceed with any combination of Add Alternate items.

PROPOSAL: PART B – ACKNOWLEDGMENT OF ADDENDA

The Bidder hereby acknowledges that all addenda become a part of the contract documents when issued, and that each such addendum has been received and utilized in the preparation of this bid. The Bidder hereby acknowledges receipt of the following addenda by inserting the number of each addendum in the blanks below and certifies that said addenda were utilized in the preparation of this bid.

ADDENDUM NUMBER _____ ADDENDUM NUMBER _____

ADDENDUM NUMBER _____ ADDENDUM NUMBER _____

PROPOSAL: PART C – BID ITEMS, QUANTITIES AND PRICES

UNIT BID PRICE CONTRACTS: The Bidder must provide the Unit Bid Price, the Total Bid Price, any Alternate Prices and the Total Construction Costs on the Proposal Attachment: Part C – Bid Items, Quantities, and Prices. In case of discrepancy, the Unit Bid Price governs. The quantities shown on the Proposal Attachment: Part C – Bid Items, Quantities and Prices are approximate only, but are considered sufficiently adequate for the purpose of comparing bids. The Jurisdiction shall only use the Total Construction Cost for comparison of the bids. The Total Construction Cost, including any Add-Alternates shall be used for determining the sufficiency of the bid security.

BASE BID CONTRACTS: The bidder must provide any Bid Prices, and alternate Prices, and the Total of the Base Bid plus any Add-alternates on the Proposal Attachment: Part C-Bid Items, Quantities, and the Prices. The Jurisdiction shall only use the Total Construction Cost for comparison of the bids. The Total Construction Cost, including any Add-Alternates shall be used for determining the sufficiency of the bid security.

PROPOSAL: PART D – GENERAL

The Bidder hereby acknowledges that the Jurisdiction, in advertising for bids for this project reserves the right to:

1. Reject any or all bids. Award of the contract, if any, to be to the lowest responsible, responsive bidder; and
2. Reject any or all alternates in determining the items to be included in the contract. Designation of the lowest responsible, responsive bidder to be based on the comparison of the total bid only, not including any alternates; and
3. Make such alterations in the documents or in the proposal quantities as it determines necessary in accordance with the contract documents after execution of the contract. Such alterations shall not be considered a waiver of any conditions of the contract documents, and shall not invalidate any of the provisions thereof; and

The Bidder hereby agrees to:

1. Enter into a contract, if this proposal is selected, in the form approved by the Jurisdiction, provide proof of registration with the Iowa Division of Labor in accordance with Chapter 91C of the Iowa Code, and furnish a performance, maintenance, and payment bond; and
2. Forfeit bid security, not as a penalty but as liquidated damages, upon failure to enter into such contract and/or furnish said bond; and
4. Substantially complete the project on or before October 30, 2026; and
5. Fully complete the project on or before April 30, 2027; and Specifier Note: Must be edited specific to each project
6. Pay liquidated damages for noncompliance with said completion provisions at the rate of Five Hundred & 00/100 Dollars (\$500.00) for each calendar day thereafter the work remains incomplete.

PROPOSAL: PART E – NON-COLLUSION AFFIDAVIT

The Bidder hereby certifies:

1. That this proposal is not affected by, contingent on, or dependent on any other proposal submitted for any improvement with the Jurisdiction; and
2. That no individual employed by the Bidder has employed any person to solicit or procure the work on this project, nor will any employee of the Bidder make any payment or agreement for payment of any compensation in connection with the procurement of this project; and
3. That no part of the bid price received by the Bidder was or will be paid to any person, corporation, firm, association, or other organization for soliciting the bid, other than the payment of their normal compensation to persons regularly employed by the Bidder whose services in connection with the construction of the project were in the regular course of their duties for the Bidder; and
4. That this proposal is genuine and not collusive or sham; that the Bidder has not colluded, conspired, connived or agreed, directly or indirectly, with any bidder or person, to submit a sham bid or to refrain from bidding, and has not in any manner, directly or indirectly, sought, by agreement or collusion, or communication or conference, with any person, to fix the bid price of the Bidder or of any other bidder, and that all statements in this proposal are true; and

5. That the individual(s) executing this proposal have the authority to execute this proposal on behalf of the Bidder.

PROPOSAL: PART F – ADDITIONAL REQUIREMENTS

The Bidder hereby agrees to comply with the additional requirements listed below which are included in this proposal and identified as proposal attachments:

ITEM NO.	DESCRIPTION OF ATTACHMENT
1.	Bid Bond (submitted in a separate, sealed envelope)
2.	Bidder Status Form and Worksheet: Authorization to Transact Business

PROPOSAL: PART G – IDENTITY OF BIDDER

The Bidder shall indicate whether the bid is Submitted by a/an:

<input type="checkbox"/> Individual, Sole Proprietorship	_____
<input type="checkbox"/> Partnership	Bidder
<input type="checkbox"/> Corporation	_____
<input type="checkbox"/> Joint-venture: all parties must join-in and execute all documents	Signature
<input type="checkbox"/> Other	By _____
	Name (Print/Type)

	Title

	Street Address

	City, State, Zip Code

	Telephone Number

The Bidder shall enter its Public Registration Number _____ - _____ issued By the Iowa Commissioner of Labor Pursuant Section 91C.5 of the Iowa Code.

NOTE: The signature on this proposal must be an original signature in ink; copies or facsimile of any signature will not be accepted.

HR Green, Inc.
Project No. 2602496
City Project No. STR26002

2026 Marshalltown Street Rehabilitation Project
Marshalltown, IA

Subscribed and sworn to before me this _____ day of _____, 20 ____.

Notary Public in and for

State of _____
County of _____

My commission expires _____

**PROPOSAL
 2026 MARSHALLTOWN STREET REHABILITATION PROJECT
 MARSHALLTOWN, IA**

PROPOSAL ATTACHMENT: PART C – BID ITEMS, QUANTITIES AND PRICES

This is a UNIT BID PRICE CONTRACT. The bidder must provide the Unit Bid Price, the Total Bid Price, and the Total Construction Cost; in case of discrepancy, the Unit Bid Price governs. The quantities shown on the Proposal Attachment: Part C – Bid Items, Quantities and Prices are approximately only, but are considered sufficiently adequate for the purpose of comparing bids. The Jurisdiction shall only use the Total Construction Cost for comparison of bids.

The Bidder is required to submit prices for all items in the Base Bid and Add Alternates. The contract shall be awarded based on the base bid amount. The City of Marshalltown reserves the right to not proceed with any Add Alternate items or proceed with any combination of Add Alternate items.

ITEM NO.		UNIT	QUANTITY	UNIT PRICE	TOTAL
	BASE BID				
1.	TOPSOIL, OFF-SITE	CY	94		
2.	SUBGRADE TREATMENT, GEOGRID, TYPE 4	SY	433		
3.	VALVE BOX ADJUSTMENT, MINOR	EA	9		
4.	MANHOLE ADJUSTMENT, MINOR	EA	29		
5.	CURB AND GUTTER, 2.5 FT	LF	1,229		
6.	BEAM CURB	LF	239		
7.	PAVEMENT, ASPHALT, STANDARD TRAFFIC, BASE, 3/4", PG 58-28S	TON	78		
8.	PAVEMENT, ASPHALT, STANDARD TRAFFIC, INTERMEDIATE, 1/2", PG 58-28S	TON	39		
9.	ASPHALT PAVEMENT SAMPLES AND TESTING	LS	1		
10.	ASPHALT OVERLAY, INTERLAYER BASE, 3/8", PG 58-34E	TON	3,611		
11.	ASPHALT OVERLAY, SURFACE, 1/2", PG 58-28S, STANDARD TRAFFIC	TON	6,319		
12.	SUBBASE OVER-EXCAVATION	TON	124		
13.	MILLING	SY	48,138		
14.	CURB AND GUTTER REMOVAL	LF	1,468		
15.	CLEANING AND PREPARATION OF BASE	MILE	3.29		
16.	PARTIAL DEPTH PATCHES, HMA	TON	430		
17.	TEMPORARY TRAFFIC CONTROL	LS	1		

ITEM NO.		UNIT	QUANTITY	UNIT PRICE	TOTAL
18.	CONVENTIONAL SEEDING, FERTILIZING, AND MULCHING, TYPE 1	AC	0.2		
19.	MOBILIZATION	LS	1		
TOTAL ITEMS 1 TO 19 BASE BID					\$
	ADD ALTERNATES				
20.	VALVE BOX ADJUSTMENT, MINOR	EA	1		
21.	MANHOLE ADJUSTMENT, MINOR	EA	5		
22.	CURB AND GUTTER, 2.5 FT	LF	112		
23.	ASPHALT OVERLAY, INTERLAYER BASE, 3/8", PG 58-34E	TON	238		
24.	ASPHALT OVERLAY, SURFACE, 1/2", PG 58-28S, STANDARD TRAFFIC	TON	362		
25.	MILLING	SY	2,136		
26.	CURB AND GUTTER REMOVAL	LF	112		
27.	CLEANING AND PREPARATION OF BASE	MILE	0.27		
28.	PARTIAL DEPTH PATCHES, HMA	TON	35		
TOTAL ITEMS 20 TO 28 ADD ALTERNATES					\$

Base Bid Total (Bid Items 1-19) \$ _____

Add Alternates Total (Bid Items 20-28) \$ _____

Total Construction Cost (Bid Items 1-28) \$ _____

NOTE: IT IS UNDERSTOOD THAT THE ABOVE QUANTITIES ARE ESTIMATED FOR THE PURPOSE OF THIS BID. ALL QUANTITIES ARE SUBJECT TO REVISION BY THE CITY. QUANTITY CHANGES WHICH AMOUNT TO TWENTY (20) PERCENT OR LESS OF THE TOTAL BID SHALL NOT AFFECT THE UNIT PRICE BID.

 Bidder

BID BOND
2026 MARSHALLTOWN STREET REHABILITATION PROJECT
MARSHALLTOWN, IA

KNOW ALL BY THESE PRESENTS:

That we, _____, as Principal, and _____, as Surety, are held and firmly bound unto City of Marshalltown, as Obligee, (hereinafter referred to as "the Jurisdiction"), in the penal sum of _____ dollars (\$_____), lawful money of the United States, for which payment said Principal and Surety bind themselves, their heirs, executors, administrators, successors, and assigns jointly and severally, firmly by these presents.

The condition of the above obligation is such that whereas the Principal has submitted to the Jurisdiction a certain proposal, in a separate envelope, and hereby made a part hereof, to enter into a contract in writing, for the following described improvements;

This project includes approximately 48,000 SY of milling, 10,000 tons of asphalt overlay including interlayer base, pavement patching, curb and gutter repairs, and related work on approximately 3.3 miles of existing streets. Specific project locations along with the kind and approximate quantity of materials to be used shall be as set forth in the Plans and Specifications.

The Surety hereby stipulates and agrees that the obligations of said Surety and its bond shall be in no way impaired or affected by any extension of the time within which the Jurisdiction may accept such bid or execute such Contract; and said Surety does hereby waive notice of any such extension.

In the event that any actions or proceedings are initiated with respect to this Bond, the parties agree that the venue thereof shall be Marshall County, State of Iowa. If legal action is required by the Jurisdiction against the Surety or Principal to enforce the provisions of the bond or to collect the monetary obligation incurring to the benefit of the Jurisdiction, the Surety or Principal agrees to pay the Jurisdiction all damages, costs, and attorney fees incurred by enforcing any of the provisions of this Bond. All rights, powers, and remedies of the Jurisdiction hereunder shall be cumulative and not alternative and shall be in addition to all rights, powers and remedies given to the Jurisdiction, by law. The Jurisdiction may proceed against Surety for any amount guaranteed hereunder whether action is brought against Principal or whether Principal is joined in any such action or actions or not.

NOW, THEREFORE, if said proposal by the Principal be accepted, and the Principal shall enter into a contract with Jurisdiction in accordance with the terms of such proposal, including the provision of insurance and of a bond as may be specified in the contract documents, with good and sufficient surety for the faithful performance of such contract, for the prompt payment of labor and material furnished in the prosecution thereof, and for the maintenance of said improvements as may be required therein, then this obligation shall become null and void; otherwise, the Principal shall pay to the Jurisdiction the full amount of the bid bond, together with court costs, attorney's fees, and any other expense of recovery.

HR Green, Inc.
Project No. 2602496
City Project No. STR26002

2026 Marshalltown Street Rehabilitation Project
Marshalltown, IA

Signed and sealed this _____ day of _____, 20_____.

SURETY:

PRINCIPAL:

By _____
Surety Company

Signature Attorney-in-Fact/Officer

Name of Attorney-in-Fact/Officer

Company Name

Company Address

City, State, Zip Code

Company Telephone Number

By _____
Bidder

Signature

Name (Print/Type)

Title

Address

City, State, Zip Code

Telephone Number

NOTE: All signatures on this bid bond must be original signatures in ink; copies or facsimile of any signature will not be accepted. This bond must be sealed with the Surety's raised, embossing seal. The Certificate or Power of Attorney accompanying this bond must be valid on its face and sealed with the Surety's raised, embossing seal.

Bidder Status Form

To be completed by all bidders

Part A

Please answer "Yes" or "No" for each of the following:

- Yes No My company is authorized to transact business in Iowa.
(To help you determine if your company is authorized, please review the worksheet on the next page).
- Yes No My company has an office to transact business in Iowa.
- Yes No My company's office in Iowa is suitable for more than receiving mail, telephone calls, and email.
- Yes No My company has been conducting business in Iowa for at least 3 years prior to the first request for bids on this project.
- Yes No My company is not a subsidiary of another business entity or my company is a subsidiary of another business entity that would qualify as a resident bidder in Iowa.

If you answered "Yes" for each question above, your company qualifies as a resident bidder. Please complete Parts B and D of this form.

If you answered "No" to one or more questions above, your company is a nonresident bidder. Please complete Parts C and D of this form.

To be completed by resident bidders

Part B

My company has maintained offices in Iowa during the past 3 years at the following addresses:

Dates: ____/____/____ to ____/____/____ Address: _____
City, State, Zip: _____

Dates: ____/____/____ to ____/____/____ Address: _____
City, State, Zip: _____

Dates: ____/____/____ to ____/____/____ Address: _____
City, State, Zip: _____

You may attach additional sheet(s) if needed.

To be completed by non-resident bidders

Part C

1. Name of home state or foreign country reported to the Iowa Secretary of State:

2. Does your company's home state or foreign country offer preferences to resident bidders, resident labor force preferences or any other type of preference to bidders or laborers? Yes No

3. If you answered "Yes" to question 2, identify each preference offered by your company's home state or foreign country and the appropriate legal citation.

You may attach additional sheet(s) if needed.

To be completed by all bidders

Part D

I certify that the statements made on this document are true and complete to the best of my knowledge and I know that my failure to provide accurate and truthful information may be a reason to reject my bid.

Signed Name: _____ Signature: _____

Firm Name: _____ Date: _____

Email Address: _____ Phone Number: _____

This form has been approved by the Department of Administrative Services Director.

309-6001 (10-24)

Worksheet: Authorization to Transact Business

This worksheet may be used to help complete Part A of the Resident Bidder Status form. If at least one of the following describes your business, you are authorized to transact business in Iowa.

Yes No

My business is currently registered as a contractor with the Iowa Division of Labor.

Yes No

My business is a sole proprietorship and I am an Iowa resident for Iowa income tax purposes.

Yes No

My business is a general partnership or joint venture. More than 50 percent of the general partners or joint venture parties are residents of Iowa for Iowa income tax purposes.

Yes No

My business is an active corporation with the Iowa Secretary of State and has paid all fees required by the Secretary of State, has filed its most recent biennial report, and has not filed articles of dissolution.

Yes No

My business is a corporation whose articles of incorporation are filed in a state other than Iowa, the corporation has received a certificate of authority from the Iowa secretary of state, has filed its most recent biennial report with the secretary of state, and has neither received a certificate of withdrawal from the secretary of state nor had its authority revoked.

Yes No

My business is a limited liability partnership which has filed a statement of qualification in this state and the statement has not been canceled.

Yes No

My business is a limited liability partnership which has filed a statement of qualification in a state other than Iowa, has filed a statement of foreign qualification in Iowa and a statement of cancellation has not been filed.

Yes No

My business is a limited partnership or limited liability limited partnership which has filed a certificate of limited partnership in this state, and has not filed a statement of termination.

Yes No

My business is a limited partnership or a limited liability limited partnership whose certificate of limited partnership is filed in a state other than Iowa, the limited partnership or limited liability limited partnership has received notification from the Iowa secretary of state that the application for certificate of authority has been approved and no notice of cancellation has been filed by the limited partnership or the limited liability limited partnership.

Yes No

My business is a limited liability company whose certificate of organization is filed in Iowa and has not filed a statement of termination.

Yes No

My business is a limited liability company whose certificate of organization is filed in a state other than Iowa, has received a certificate of authority to transact business in Iowa and the certificate has not been revoked or canceled.

HR Green, Inc.
Project No. 2602496
City Project No. STR26002

2026 Marshalltown Street Rehabilitation Project
Marshalltown, IA

CONTRACT
2026 MARSHALLTOWN STREET REHABILITATION PROJECT
MARSHALLTOWN, IA

THIS CONTRACT, made and entered into this _____ day of _____, 2026, by and between the City of Marshalltown by its Mayor, upon order of its City Council hereinafter called the "Jurisdiction", and Contractor, hereinafter called the "Contractor".

WITNESSETH:

The Contractor hereby agrees to complete the work comprising the below referenced improvement as specified in the contract documents, which are officially on file with the Jurisdiction, in the office of the City Clerk. This contract includes all contract documents. The work under this contract shall be constructed in accordance with the latest Edition of the Urban Standard Specifications for Public Improvements, as further modified by the supplemental specifications and special provisions included in said contract documents, and the Contract Attachment, which is attached hereto. The Contractor further agrees to complete the work in strict accordance with said contract documents, and guarantee the work as required by law, for the time required in said contract documents, after its acceptance by the Jurisdiction.

This contract is awarded and executed for completion of the work specified in the contract documents for the bid prices shown on the Contract Attachment: Bid Items, Quantities and Prices which were proposed by the Contractor in its proposal submitted in accordance with Notice to Bidders and Notice of Public Hearing for the following described improvements:

This project includes approximately 48,000 SY of milling, 10,000 tons of asphalt overlay including interlayer base, pavement patching, curb and gutter repairs, and related work on approximately 3.3 miles of existing streets. Specific project locations along with the kind and approximate quantity of materials to be used shall be as set forth in the Plans and Specifications.

The Contractor agrees to perform said work for and in consideration of the Jurisdiction's payment of the bid amount of `WrittenContractAmount` dollars (`$ContractNumericAmount`), which amount shall constitute the required amount of the performance, maintenance, and payment bond. The Contractor hereby agrees work shall be substantially complete on or before October 30, 2026, and shall be fully completed on or before April 30, 2027, and to pay liquidated damages for noncompliance with said completion provisions at a rate of Five Hundred & 00/100 Dollars (`$500.00`) dollars for each calendar day that the work remains incomplete.

CONTRACT

- 1 -

HR Green, Inc.
Project No. 2602496
City Project No. STR26002

2026 Marshalltown Street Rehabilitation Project
Marshalltown, IA

IN WITNESS WHEREOF, the Parties hereto have executed this instrument, in triplicate on the date first shown written.

JURISDICTION: City of Marshalltown

CONTRACTOR:

By _____
Mike Ladehoff, Mayor

Contractor

(Seal)
ATTEST:

By _____
CAuthorizedSignature, CAuthorizedTitle

Alicia Hunter, City Clerk

Print Name, Title

CAddress1
Street Address

CAddress2
City, State, Zip Code

CPhone
Telephone

CONTRACTOR PUBLIC REGISTRATION INFORMATION To Be Provided By:

1. All Contractors: The Contractor shall enter its Public Registration No. _____ issued by the Iowa Commissioner of Labor pursuant to Section 91C.5 of the Iowa Code.
2. Out-of-State Contractors:
 - A. Pursuant to Section 91C.7 of the Iowa Code, an out-of-state contractor, before commencing a contract in excess of five thousand dollars in value in Iowa, shall file a bond with the division of labor services of the department of workforce development. The contractor should contact 515-242-5871 for further information. Prior to contract execution, the Engineer may forward a copy of this contract to the Iowa Department of Workforce Development as notification of pending construction work. It is the contractor's responsibility to comply with said Section 91C.7 before commencing this work.

CONTRACT ATTACHMENT: ITEM 2: BID ITEMS, QUANTITIES

THIS CONTRACT IS AWARDED AND EXECUTED FOR COMPLETION OF THE WORK SPECIFIED IN THE CONTRACT DOCUMENTS FOR THE BID PRICES TABULATED BELOW AS PROPOSED BY THE CONTRACTOR IN ITS PROPOSAL SUBMITTED IN ACCORDANCE WITH NOTICE TO BIDDERS AND NOTICE OF PUBLIC HEARING. ALL QUANTITIES ARE SUBJECT TO REVISION BY THE JURISDICTION. BASED ON BIDS RECEIVED, THE CITY RESERVES THE RIGHT TO ADJUST QUANTITIES AS NECESSARY TO MAXIMIZE FUNDS BUDGETED FOR THIS PROJECT.

ITEM NO.		UNIT	QUANTITY	UNIT PRICE	TOTAL
	BASE BID				
1.	TOPSOIL, OFF-SITE	CY	94		
2.	SUBGRADE TREATMENT, GEOGRID, TYPE 4	SY	433		
3.	VALVE BOX ADJUSTMENT, MINOR	EA	9		
4.	MANHOLE ADJUSTMENT, MINOR	EA	29		
5.	CURB AND GUTTER, 2.5 FT	LF	1229		
6.	BEAM CURB	LF	239		
7.	PAVEMENT, ASPHALT, STANDARD TRAFFIC, BASE, 3/4", PG 58-28S	TON	78		
8.	PAVEMENT, ASPHALT, STANDARD TRAFFIC, INTERMEDIATE, 1/2", PG 58-28S	TON	39		
9.	ASPHALT PAVEMENT SAMPLES AND TESTING	LS	1		
10.	ASPHALT OVERLAY, INTERLAYER BASE, 3/8", PG 58-34E	TON	3611		
11.	ASPHALT OVERLAY, SURFACE, 1/2", PG 58-28S, STANDARD TRAFFIC	TON	6319		
12.	SUBBASE OVER-EXCAVATION	TON	124		
13.	MILLING	SY	48138		
14.	CURB AND GUTTER REMOVAL	LF	1468		
15.	CLEANING AND PREPARATION OF BASE	MILE	3.29		
16.	PARTIAL DEPTH PATCHES, HMA	TON	430		
17.	TEMPORARY TRAFFIC CONTROL	LS	1		
18.	CONVENTIONAL SEEDING, FERTILIZING, AND MULCHING, TYPE 1	AC	0.2		
19.	MOBILIZATION	LS	1		
TOTAL ITEMS 1 TO 19 BASE BID					\$
	ADD ALETERNATES				

HR Green, Inc.
 Project No. 2602496
 City Project No. STR26002

2026 Marshalltown Street Rehabilitation Project
 Marshalltown, IA

ITEM NO.		UNIT	QUANTITY	UNIT PRICE	TOTAL
20.	VALVE BOX ADJUSTMENT, MINOR	EA	1		
21.	MANHOLE ADJUSTMENT, MINOR	EA	5		
22.	CURB AND GUTTER, 2.5 FT	LF	112		
23.	ASPHALT OVERLAY, INTERLAYER BASE, 3/8", PG 58-34E	TON	238		
24.	ASPHALT OVERLAY, SURFACE, 1/2", PG 58-28S, STANDARD TRAFFIC	TON	362		
25.	MILLING	SY	2136		
26.	CURB AND GUTTER REMOVAL	LF	112		
27.	CLEANING AND PREPARATION OF BASE	MILE	0.27		
28.	PARTIAL DEPTH PATCHES, HMA	TON	35		
TOTAL ITEMS 20 TO 28 ADD ALTERNATES					\$

Base Bid Total (Bid Items 1-19) \$ _____

Add Alternates Total (Bid Items 20-28) \$ _____

Total Construction Cost (Bid Items 1-28) \$ _____

HR Green, Inc.
Project No. 2602496
City Project No. STR26002

2026 Marshalltown Street Rehabilitation Project
Marshalltown, IA

**PERFORMANCE, PAYMENT AND MAINTENANCE BOND
2026 MARSHALLTOWN STREET REHABILITATION PROJECT
MARSHALLTOWN, IA**

KNOW ALL BY THESE PRESENTS:

That we, Contractor as Principal (hereinafter the "Contractor" or "Principal" and _____, as Surety are held and firmly bound unto the City of Marshalltown, as Obligee (hereinafter referred to as "the Jurisdiction"), and to all persons who may be injured by any breach of any of the conditions of this Bond in the penal sum of _____ dollars (\$ _____) lawful money of the United States, for the payment of which sum, well and truly to be made, we bind ourselves, our heirs, legal representatives and assigns, jointly or severally, firmly by these presents.

The conditions of the above obligations are such that whereas said Contractor entered into a contract with the Jurisdiction, bearing date the _____ day of _____, 2026, (hereinafter the "Contract") wherein said Contractor undertakes and agrees to construct the following described improvements:

This project includes approximately 48,000 SY of milling, 10,000 tons of asphalt overlay including interlayer base, pavement patching, curb and gutter repairs, and related work on approximately 3.3 miles of existing streets. Specific project locations along with the kind and approximate quantity of materials to be used shall be as set forth in the Plans and Specifications.

and to faithfully perform all the terms and requirements of said Contract within the time therein specified, in a good and workmanlike manner, and in accordance with the Contract Documents. Provided, however, that one year after the date of acceptance as complete of the work under the above referenced Contract, the maintenance portion of this Bond shall continue in force but the penal sum for maintenance shall be reduced to the sum of \$ _____ which is the cost associated with those items shown on the proposal and in the Contract which require a maintenance bond period in excess of one year.

It is expressly understood and agreed by the Contractor and Surety in this bond that the following provisions are a part of this Bond and are binding upon said Contractor and Surety, to-wit:

1. **PERFORMANCE:** The Contractor shall well and faithfully observe, perform, fulfill and abide by each and every covenant, condition and part of said Contract and Contract Documents, by reference made a part hereof, for the above referenced improvements, and shall indemnify and save harmless the Jurisdiction from all outlay and expense incurred by the Jurisdiction by reason of the Contractor's default of failure to perform as required. The Contractor shall also be responsible for the default or failure to perform as required under the Contract and Contract Documents by all its subcontractors, suppliers, agents, or employees furnishing materials or providing labor in the performance of the Contract.

2. **PAYMENT:** The Contractor and the Surety on this Bond are hereby agreed to pay all just claims submitted by persons, firms, subcontractors, and corporations furnishing materials for or performing labor in the performance of the Contract on account of which this Bond is given, including but not limited to claims for all amounts due for labor, materials, lubricants, oil, gasoline, repairs on machinery, equipment and tools, consumed or used by the Contractor or any subcontractor, wherein the same are not satisfied out of the portion of the contract price which the Jurisdiction is required to retain until completion of the improvement, but the Contractor and Surety shall not be liable to said persons, firms, or corporations unless the claims of said claimants against said portion of the contract price shall have been established as provided by law. The Contractor and Surety hereby bind themselves to the obligations and conditions set forth in Chapter 573, Code of Iowa, which by this reference is made a part hereof as though fully set out herein.

3. **MAINTENANCE:** The Contractor and the Surety on this Bond hereby agree, at their own expense:
 - A. To remedy any and all defects that may develop in or result from work to be performed under the Contract by reason of defects in workmanship or materials used in construction of said work, Contractor shall furnish a warranty bond. The warranty bond must be in a bond amount of one hundred (100) percent of the final contract price for the first two (2) years and twenty-five (25) percent of the final Contract Price for the last two (2) years. The warranty bond period will extend to a date four (4) years after Substantial Completion of the Work.
 - B. To keep all work in continuous good repair.
 - C. To pay the Jurisdiction's reasonable costs of monitoring and inspection to assure that any defects are remedied, and to repay the Jurisdiction all outlay and expense incurred as a result of Contractor's and Surety's failure to remedy any defect as required by this section; and
 - D. Contractor's and Surety's agreement herein made extends to defects in workmanship or materials not discovered or known to the Jurisdiction at the time such work was accepted.

4. **GENERAL:** The Contractor and every Surety on this Bond shall be deemed and held bound, any contract to the contrary notwithstanding, to the following provisions:
 - A. To consent without notice to any extension of time to the Contractor in which to perform the Contract;
 - B. To consent without notice to any change in the Contract or Contract Documents, which thereby increases the total contract price and the penal sum of this bond, provided that all such changes do not, in the aggregate, involve an increase of more than twenty percent of the total contract price, and that this bond shall then be released as to such excess increase; and
 - C. To consent without notice that this Bond shall remain in full force and effect until the Contract is completed, whether completed within the specified contract period, within an extension thereof, or within a period of time after the contract period has elapsed and the liquidated damage penalty is being charged against the Contractor.
 - D. That no provision of this Bond or of any other contract shall be valid which limits to less than five years after the acceptance of the work under the Contract the right to sue on this Bond.
 - E. That as used herein, the phrase "all outlay and expense" is not to be limited in any way, but shall include the actual and reasonable costs and expenses incurred by the Jurisdiction including interest, benefits and overhead where applicable. Accordingly, "all outlay and expense" would include but not be limited to all contract or employee expense, all equipment usage or rental,

materials, testing, outside experts, attorneys fees (including overhead expenses of the Jurisdiction's staff attorneys), and all costs and expenses of litigation as they are incurred by the Jurisdiction. It is intended the Contractor and Surety will defend and indemnify the Jurisdiction on all claims made against the Jurisdiction on account of Contractor's failure to perform as required in the Contract and Contract Documents, that all agreements and promises set forth in the Contract and Contract Documents, in approved change orders, and in this Bond will be fulfilled, and that the Jurisdiction will be fully indemnified so that it will be put into the position it would have been in had the Contract been performed in the first instance as required.

In the event the Jurisdiction incurs any "outlay and expense" in defending itself with respect to any claim as to which the Contractor or Surety should have provided the defense, or in the enforcement of the promises given by the Contractor in the Contract, Contract Documents, or approved change orders, or in the enforcement of the promises given by the Contractor and Surety in this Bond, the Contractor and Surety agree that they will make the Jurisdiction whole for all such outlay and expense, provided that the Surety's obligation under this bond shall not exceed 125% of the penal sum of this bond.

In the event that any actions or proceedings are initiated with respect to this Bond, the parties agree that the venue thereof shall be Marshall, State of Iowa. If legal action is required by the Jurisdiction to enforce the provisions of this Bond or to collect the monetary obligation incurring to the benefit of the Jurisdiction, the Contractor and the Surety agree, jointly and severally, to pay the Jurisdiction all outlay and expense incurred therefor by the Jurisdiction. All rights, powers, and remedies of the Jurisdiction hereunder shall be cumulative and not alternative and shall be in addition to Surety for any amount guaranteed hereunder whether action is brought against the Contractor or whether Contractor is joined in any such action or actions or not.

NOW THEREFORE, the condition of this obligation is such that if said Principal shall faithfully perform all the promises of the Principal, as set forth and provided in the Contract, in the Contract Documents, and in this Bond, then this obligation shall be null and void, otherwise it shall remain in full force and effect.

When a word, term, or phrase is used in this Bond, it shall be interpreted or construed first as defined in this Bond, the Contract, or the Contract Documents; second, if not defined in the Bond, Contract, or Contract Documents, it shall be interpreted or construed as defined in applicable provisions of the Iowa Code; third, if not defined in the Iowa Code, it shall be interpreted or construed according to its generally accepted meaning in the construction industry; and fourth, if it has no generally accepted meaning in the construction industry, it shall be interpreted or construed according to its common or customary usage.

Failure to specify or particularize shall not exclude terms or provisions not mentioned and shall not limit liability hereunder. The Contract and Contract Documents are hereby made a part of this Bond.

Witness our hands, in triplicate, this _____ day of _____, 20____.

Surety Countersigned By:

PRINCIPAL:

Name of Resident Commission Agent

Contractor

Company Name

By: _____
Signature

Company Address

Printed Name, Title

HR Green, Inc.
Project No. 2602496
City Project No. STR26002

2026 Marshalltown Street Rehabilitation Project
Marshalltown, IA

City, State, Zip Code

Company Telephone Number

SURETY:

Surety Company

By: _____
Signature Attorney-in-Fact Officer

Name of Attorney-in-Fact Officer

Company Name

Company Address

City, State, Zip Code

Company Telephone Number

NOTE: All signatures on this performance, maintenance & payment bond must be original signatures in ink; copies or facsimile of any signature will not be accepted. This bond must be sealed with the Surety's raised, embossing seal. The Certificate or Power of Attorney accompanying this bond must be valid on its face and sealed with the Surety's raised, embossing seal.

**SPECIAL PROVISIONS
2026 MARSHALLTOWN STREET REHABILITATION PROJECT
MARSHALLTOWN, IA**

INDEX

1. FORM OF SPECIFICATIONS	10. EMPLOYMENT PRACTICES
2. GENERAL PROVISIONS AND COVENANTS	11. WORK HOURS
3. PLANS AND SPECIFICATIONS	12. DUST ABATEMENT
4. SERVICE FACILITIES	13. QUANTITIES
5. MINOR WORK	14. MAINTENANCE BOND AND WARRANTY PERIODS
6. WORKING DAYS	15. CONSTRUCTION STAKING
7. CONSTRUCTION FACILITIES BY CONTRACTOR	16. PRECONSTRUCTION MEETING
8. SOILS BORINGS	17. PROGRESS MEETINGS
9. CONSTRUCTION ON HIGHWAY RIGHT-OF-WAYS	

1. FORM OF SPECIFICATIONS

- 1.1. "Specifications" shall mean the 2026 Edition of the SUDAS Standard Specifications.
- 1.2. Omissions of words or phrases such as "the Contractor shall", "in accordance with", "shall be", "as noted on the Plans", "according to the Plans", "a", "an", "the" and "all" are intentional; supply omitted words or phrases by inference.
- 1.3. "Owner", and "City" shall mean the City of Marshalltown, acting through the City Council.
- 1.4. "Person" shall mean any individual, partnership, limited partnership, joint venture, society, association, joint stock company, corporation, limited liability company, estate, receiver, trustee, assignee, or referee, whether appointed by a court or otherwise, and any combination of individuals.
- 1.5. "Engineer" shall mean the Engineer for the City of Marshalltown or designated agent.
- 1.6. "Standard Drawings" shall mean the Figures bound within the SUDAS Standard Specifications and/or the Typical Drawings bound within the plans.
- 1.7. "Work" shall mean the work to be done and the equipment, supplies, and materials to be furnished under the contract unless some other meaning is indicated by the context.
- 1.8. "Or equal" shall follow manufacturers names used to establish standards and, if not stated, is implied.
- 1.9. "Punch List" list of incomplete items of Work and of items of Work which are not in conformance with the Contract. The list will be prepared by the Engineer's representative when the Contractor (1) notifies the Engineer's representative in writing that the Work has been completed in accordance with the contract and (2) requests in writing that the Owner accept the Work.
- 1.10. "Substantial Completion" in addition to the definition provided in the General Conditions, the following applies: Sufficient completion of the project or the portion thereof to permit utilization of the project, or portion thereof for its intended purpose. Substantial completion requires not only that the work be sufficiently completed to permit utilization, but that the

Owner can effectively utilize the substantially completed Work. Determination of substantial completion is solely at the discretion of the Owner. Substantial completion does not mean complete in accordance with the Contract nor shall substantial completion of all or any part of the project entitle the Contractor to acceptance under the Contract.

- 1.11. "Final Completion" when the Engineer deems the Project and Punch List fully complete in accordance with Plans and Specification, and when all items including but not limiting to: excess building materials, concrete forms, construction trailers, field offices, and temporary traffic control have been removed from site, the Engineer shall notify the Owner in writing and recommend final acceptance of work. Sales and Use Tax Forms and Lien Waivers do not have to be completed but are encouraged to be completed as a condition of Final Completion. The date of final completion shall be the date the Engineer's written recommendation of final acceptance to the Owner.

2. GENERAL PROVISIONS AND COVENANTS

- 2.1. The general provisions and covenants, Division 1 of the SUDAS Standard Specifications are modified as follows:
 - 2.1.1. Section 1020.1.09.B, Unit Price Attachment.

A computer generated unit price attachment may be submitted by the Bidder as specified by this Section.
 - 2.1.2. Section 1050.1.05 Shop Drawings, Certificates and Equipment Lists.

The Contractor shall submit a minimum of three (3) copies plus any additional required by the Contractor.
 - 2.1.3. Railroad Protection
Liability insurance and permits. None

3. PLANS AND SPECIFICATIONS

- 3.1. Engineer will furnish up to five (5) sets of Plans and Specifications after award of contract. Contractor shall compensate Engineer for printing costs for additional copies required.
- 3.2. Subcontractors and suppliers will be furnished copies of Plans and Specifications only at request of Contractor. Engineer will be compensated for printing costs by Contractor.

4. SERVICE FACILITIES

- 4.1. The Contractor will be required to make arrangements for all services required during the construction period and pay for such services at no additional cost to the Owner.

5. MINOR WORK

- 5.1. Any minor work not specifically mentioned in the Specifications as shown on the Plans but obviously necessary for the proper completion of the work shall be considered as being a part of and included in the contract and shall be executed in the proper manner and the Contractor shall not be entitled to extra or additional compensation for the same.

6. WORKING DAYS/COMMUNITY ACTIVITIES

- 6.1. Except for such work as may be required to properly maintain lights and barricades, no work will be permitted on Sundays or legal holidays without specific permission of the Engineer.

6.2. The following Community Events are scheduled, Contractor is required to coordinate with Owner as needed to allow use of adjacent public property.

6.2.1. The City of Marshalltown will be an overnight host town for RAGBRAI on Wednesday, July 22, 2026 through Thursday, July 23, 2026. All streets associated with this project must be open and passable from 5AM on July 22, 2026 through 5PM on July 23, 2026.

7. CONSTRUCTION FACILITIES BY CONTRACTOR

- 7.1. Provide telephone, attended at all times during the working day; provide liaison between telephone and construction personnel for expeditious handling of messages.
- 7.2. Provide suitable storage buildings necessary for proper storage of materials and equipment.
- 7.3. Location of all construction facilities, including Project construction plant and yard, subject to approval by Engineer; remove all construction facilities upon completion of work.
- 7.4. Provide and maintain suitable sanitary facilities for construction personnel for duration of work; remove upon completion of work.
- 7.5. Provide fences, barricades, and/or watch persons to prevent access of unauthorized persons to site where work is in progress.
- 7.6. Provide telephone number(s) at which responsible representatives of Contractor can be reached evenings, weekends and holidays.

8. SOIL BORINGS

- 8.1. None

9. CONSTRUCTION ON HIGHWAY RIGHT-OF-WAYS

- 9.1. All work on this project will be within City Right-of-Way, Easements or Public Property.

10. EMPLOYMENT PRACTICES

- 10.1. Neither the Contractor nor the contractor's Subcontractors shall employ any person whose physical or mental condition is such that this employment will endanger the health and safety of anyone employed on the Project.
- 10.2. The Contractor shall not commit any of the following employment practices and agrees to include the following clauses in any Subcontracts:
 - 10.2.1. To discharge from employment or refuse to hire any individual because of sex, race, color, religion, national origin, sexual orientation, marital status, age, or disability unless such disability is related to job performance of such person or employee.
 - 10.2.2. To discriminate against any individual in terms, conditions, or privileges of employment because of sex, race, color, religion, national origin, sexual orientation, marital status, age, or disability unless such disability is related to job performance of such person or employee.

11. WORK HOURS

- 11.1. The Contractor will be required to limit the Contractor's work hours on the Project from 7:00 a.m. to 6:00 p.m., Monday through Saturday unless otherwise directed by the Engineer.

12. DUST ABATEMENT

- 12.1. The Contractor shall make a reasonable effort to assure dust does not become a problem. The Engineer reserves the right to stop Contractor's operations whenever dust becomes a problem on the Project and direct the Contractor to revise operations to solve the dust problem.

13. QUANTITIES

- 13.1. The Contractor is to realize some of the quantities on this Project are best estimates and may vary from actual conditions at time of construction of the Project. Quantities must be regarded as approximate only, and are given as a guide to the Bidder and for comparison of Bids. The City reserves the right to increase or decrease these quantities as designated in the contract, and the Contractor will be paid for only as much work as the Contractor is required to do by the City at the unit price stated in the Proposal.

14. MAINTENANCE BOND AND WARRANTY PERIODS

- 14.1. The requirements of the Payment, Performance and Maintenance Bond warranty period are modified as follows:
 - 14.1.1 To remedy any and all defects that may develop in or result from work to be performed under the Contract by reason of defects in workmanship or materials used in construction of said work, Contractor shall furnish a warranty bond. The warranty bond must be in a bond amount of one hundred (100) percent of the final contract price for the first two (2) years and twenty-five (25) percent of the final Contract Price for the last two (2) years. The warranty bond period will extend to a date four (4) years after Substantial Completion of the Work

15. CONSTRUCTION STAKING

- 15.1. The City of Marshalltown, or an authorized representative, will provide all construction staking. The Contractor shall provide 2 Working Day written notice to the Engineer to begin requested survey, staking, or layout work. Subsequent staking shall be requested two working days in advance of the staking needs. Contractor shall be responsible for layout of all other construction items including but not limited to, traffic control, structure removal, pavement markings, seeding, inlet filters and silt fence. One-time staking shall be provided. Any re-staking shall be paid for by the Contractor.
- 15.2. Construction staking provided by the City on the project will include the following:
 - 15.2.1. Removal Limits
 - Locate removals for pavement, sidewalks, drives, curbs. Removals not authorized or outside of removal limits shall be at Contractor expense.
 - 15.2.2. Pavement Removals and saw cut lines
 - Mark the pavement removal limits.

16. PRECONSTRUCTION MEETING

- 16.1. Engineer will schedule a meeting after Notice of Award.
 - 16.1.1. Attendance Required:
 - 16.1.2. Owner
 - 16.1.3. Engineer
 - 16.1.4. Contractor
 - 16.1.5. Contractor's Superintendent
 - 16.1.6. Major Subcontractors
 - 16.1.7. Utility Companies
- 16.2. Agenda:
 - 16.2.1. Submission of list of Subcontractors, list of Products, schedule of values, and progress schedule.
 - 16.2.2. List and schedule of submittals/shop drawings.
 - 16.2.3. Designation of personnel representing the parties in Contract and the Engineer.
 - 16.2.4. Procedures and processing of field decisions, submittals, substitutions, applications for payments, proposal request, Change Orders, and Contract closeout procedures.
 - 16.2.5. Use of premises by Owner and Contractor.
 - 16.2.6. Owner's requirements.
 - 16.2.7. Facilities and controls provided by Owner.
 - 16.2.8. Temporary utilities provided by Owner.
 - 16.2.9. Security and housekeeping procedures.
 - 16.2.10. Scheduling
 - 16.2.11. Procedures for testing
 - 16.2.12. Procedures for maintaining record documents
 - 16.2.13. Project Schedule
- 16.3. Engineer shall record minutes and distribute copies within two days after meeting to participants, with copies to Contractor, Owner, participants, and those affected by decisions made.

17. PROGRESS MEETINGS

- 17.1. Contractor to schedule and administer meetings throughout progress of the Work at maximum monthly intervals or as established at preconstruction meeting.
- 17.2. Contractor to make arrangements for meetings, prepare agenda with copies for participants, preside at meetings, record minutes, and distribute copies within two days to Engineer, Owner, participants, and those affected by decisions made.
- 17.3. Attendance Required: Job superintendent, major Subcontractors and suppliers, Owner, Engineer, as appropriate to agenda topics for each meeting.

17.4. Agenda:

- 17.4.1. Review minutes of previous meetings.
- 17.4.2. Address public concerns and complaints.
- 17.4.3. Review of Work progress.
- 17.4.4. Field observations, problems, and decisions.
- 17.4.5. Identification of problems which impede planned progress.
- 17.4.6. Review of submittals schedule and status of submittals.
- 17.4.7. Review of off-site fabrication and delivery schedules.
- 17.4.8. Maintenance of progress schedule.
- 17.4.9. Corrective measures to regain projected schedules.
- 17.4.10. Planned progress during succeeding work period.
- 17.4.11. Coordination of projected progress.
- 17.4.12. Maintenance of quality and work standards.
- 17.4.13. Effect of proposed changes on progress schedule and coordination.
- 17.4.14. Other business relating to Work.
- 17.4.15. Schedule next meeting.

2026 STREET REHABILITATION

CITY OF MARSHALLTOWN, IOWA

HRG Project No.: 2602496

CITY Project No.: STR26002 2026 Street Rehabilitation Project_HMA

INDEX OF SHEETS	
No.	DESCRIPTION
A Sheets	Title Sheets
A.1	Title Sheet
B Sheets	Typical Cross Sections and Details
B.1 - 3	Typical Cross Sections and Details
C Sheets	Quantities and General Information
C.1 - 3	Estimated Project Quantities
D Sheets	Mainline Plan and Profile Sheets
D.1	Key Map & Legend
D.2 - 24	Plan & Profile Sheets

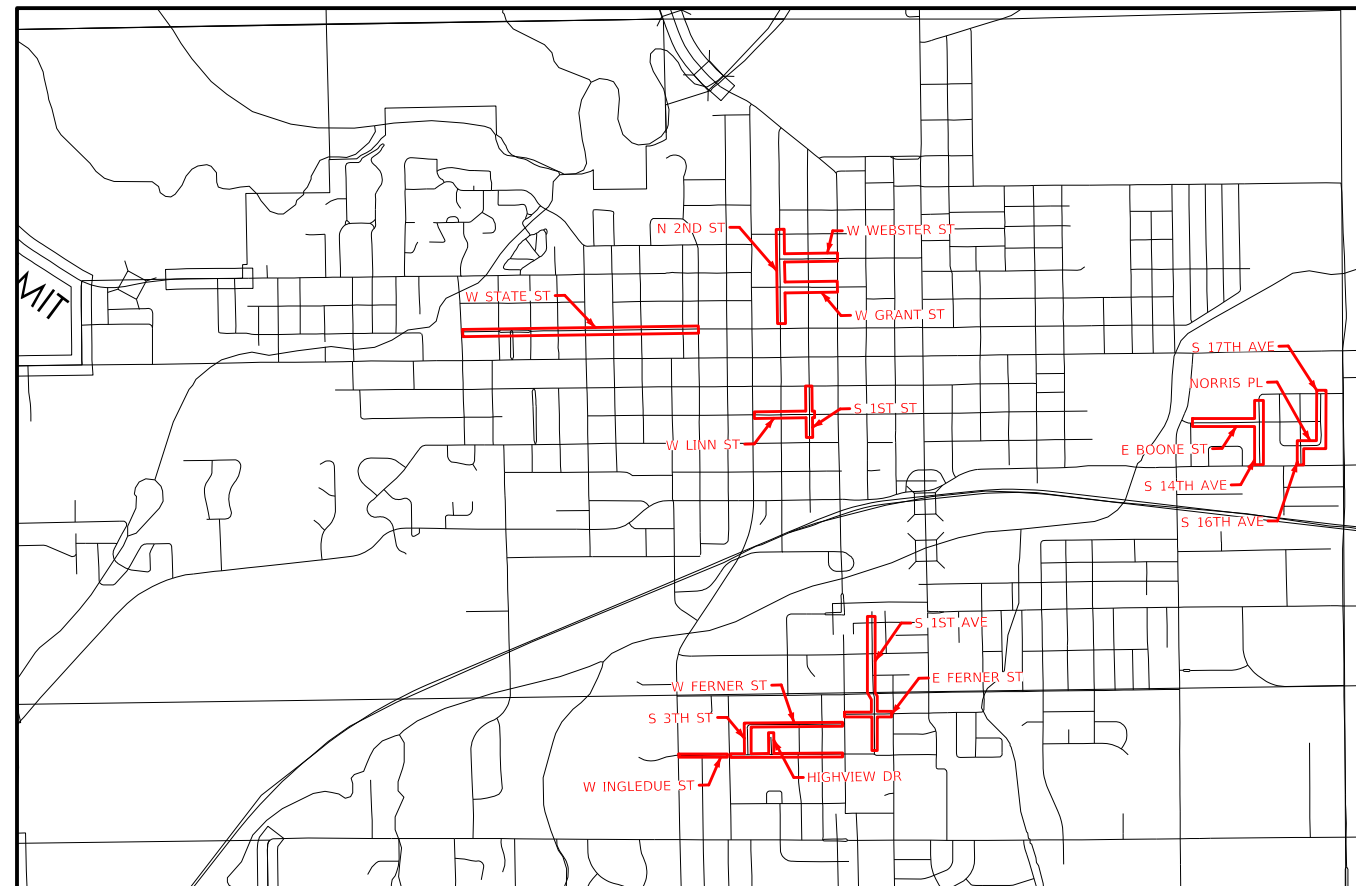

LOCATION MAP

NOT TO SCALE

THE PROPOSED IMPROVEMENTS INCLUDED IN THESE DRAWINGS HAVE BEEN DESIGNED IN ACCORDANCE WITH THE IOWA STATEWIDE URBAN DESIGN AND SPECIFICATIONS (SUDAS, 2026 EDITION), MARSHALLTOWN SUPPLEMENTARY SPECIFICATIONS TO AMEND THE IOWA STATEWIDE URBAN DESIGN AND SPECIFICATIONS (SUDAS) (JULY 2023) AND SPECIAL PROVISIONS.

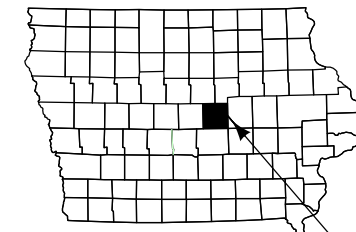

MARSHALL COUNTY



8710 EARHART LN SW | CEDAR RAPIDS, IOWA 52404-8947
 Phone: 319.841.4000 | Toll Free: 800.728.7805 | Fax: 319.841.4012 | HRGreen.com

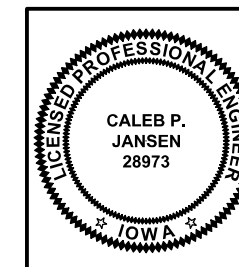

I hereby certify that this engineering document was prepared by me or under my direct personal supervision and that I am a duly licensed Professional Engineer under the laws of the State of Iowa.

Caleb Jansen 05-04-2026
 CALEB P. JANSEN, P.E. DATE
 License Number: 28973
 My license renewal date is December 31, 2027.
 Pages or sheets covered by this seal:
 A.1, B.1-3, C.1-3, D.1-24

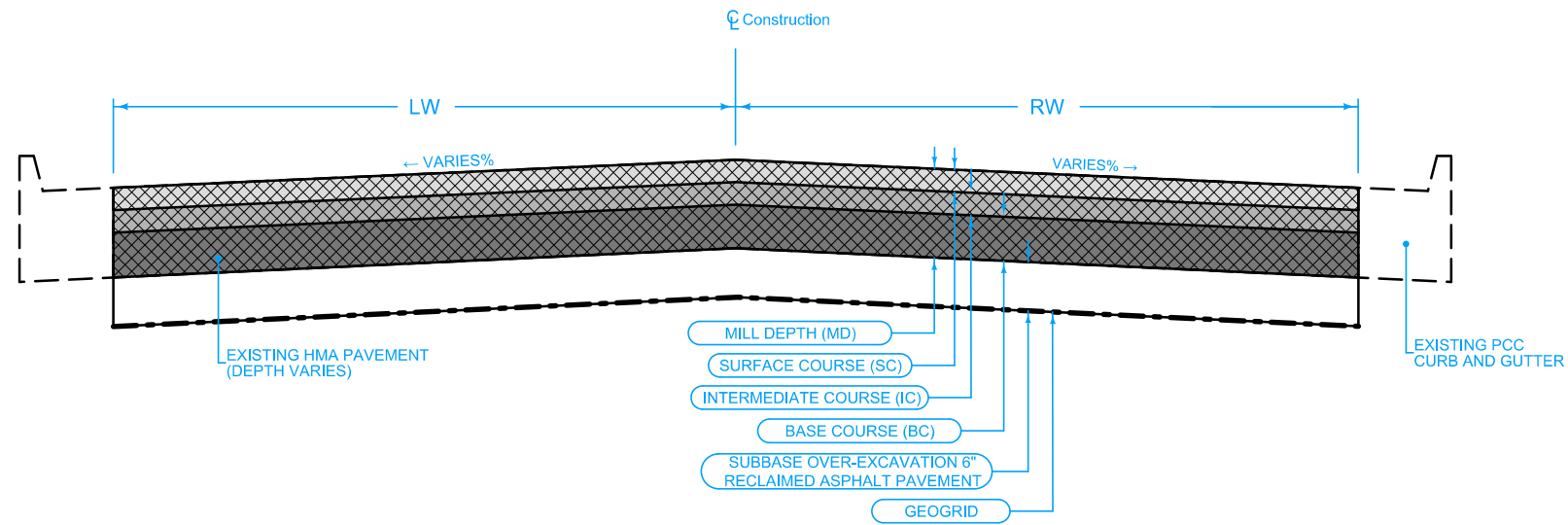

ROAD IDENTIFICATION	BEGIN STATION	END STATION	LW Feet	RW Feet	MD Inch	SC Inch	IC Inch	BC Inch
SOUTH 1ST AVENUE	416+34.94	418+51.32	10.0	10.0	6.0	1.5	1.5	3.0

**TYPICAL CROSS SECTION
FULL DEPTH HMA MILL AND OVERLAY**

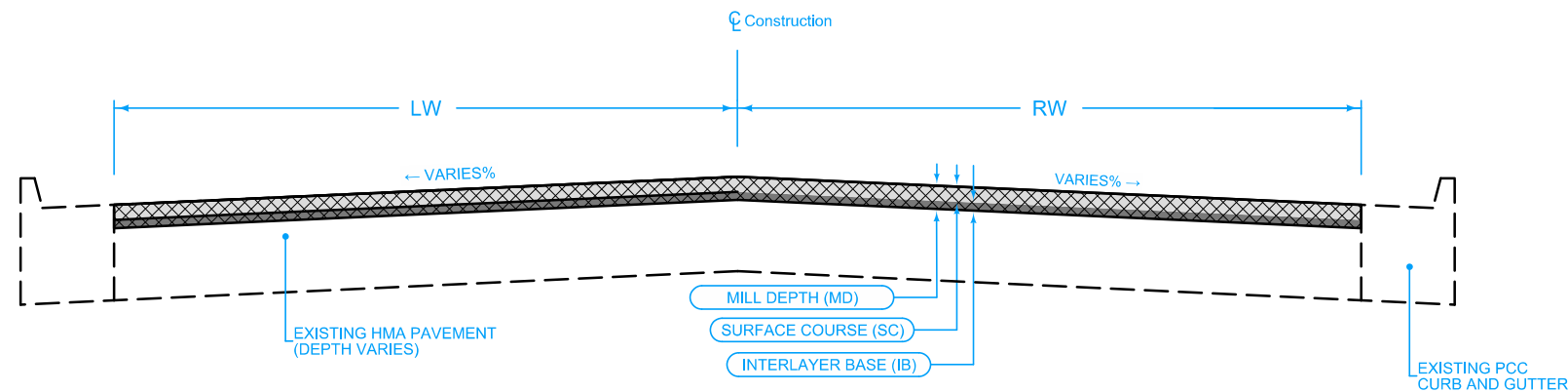

ROAD IDENTIFICATION	BEGIN STATION	END STATION	LW Feet	RW Feet	MD Inch	SC Inch	IB Inch
WEST INGLEDUE STREET	308+81.99	318+35.62	15.0	15.0	3.0	2.0	1.0

**TYPICAL CROSS SECTION
PARTIAL DEPTH HMA MILL AND OVERLAY**

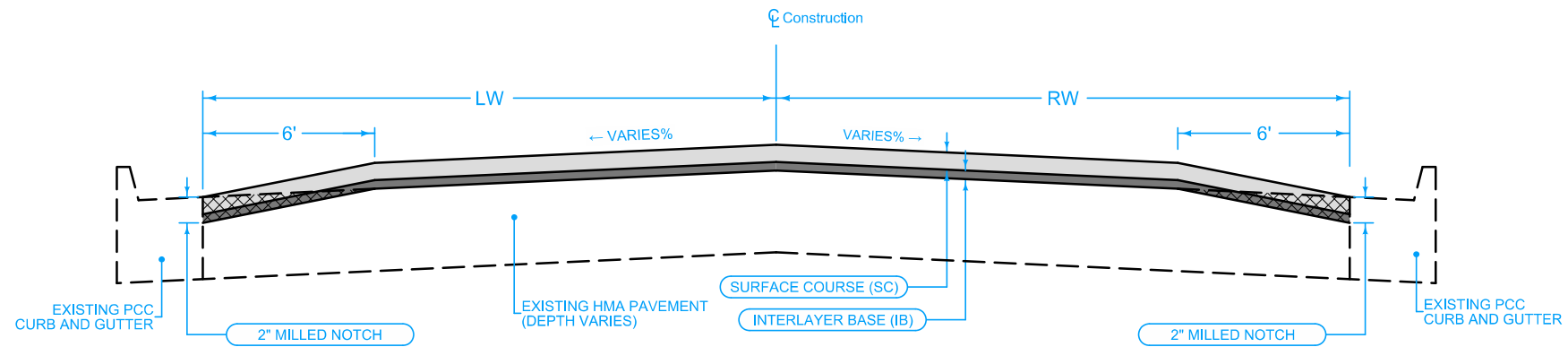

ROAD IDENTIFICATION	BEGIN STATION	END STATION	LW Feet	RW Feet	SC Inch	IB Inch
WEST INGLEDUE STREET	300+41.43	307+61.79	13.0	13.0	1.5	1.0
WEST INGLEDUE STREET	318+35.62	325+60.91	13.0	13.0	1.5	1.0
SOUTH 3RD STREET	330+34.65	334+29.80	13.0	13.0	1.5	1.0
WEST FERNER STREET	360+00.00	374+84.99	13.0	13.0	1.5	1.0
HIGHVIEW DRIVE	340+35.73	342+27.61	13.0	13.0	1.5	1.0
EAST FERNER STREET	400+39.88	407+08.17	13.0	13.0	1.5	1.0
SOUTH 1ST AVENUE*	410+39.86	416+15.33	10.0	10.0	1.5	1.0

* NOTE: ADJUST EDGE NOTCH WIDTH TO 4.0'

**TYPICAL CROSS SECTION
HMA OVERLAY WITH MILLED NOTCHES**

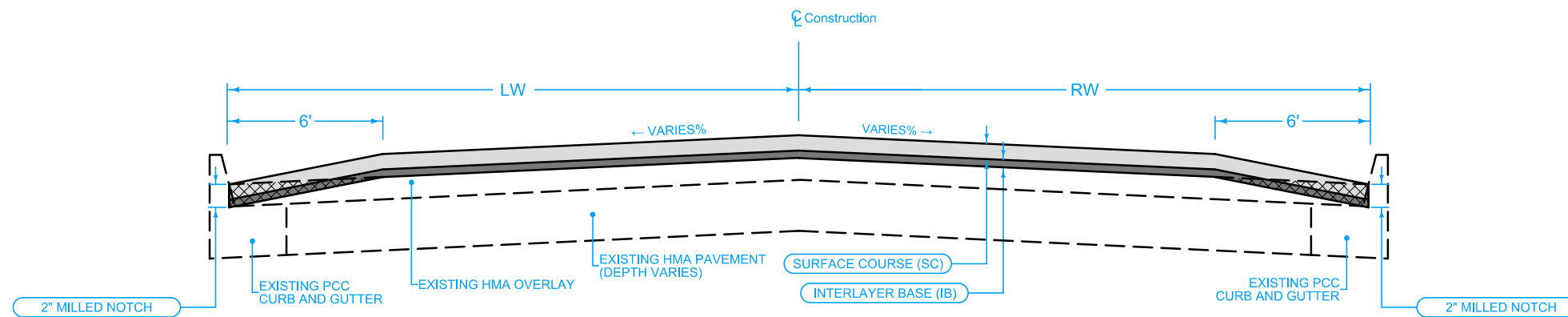
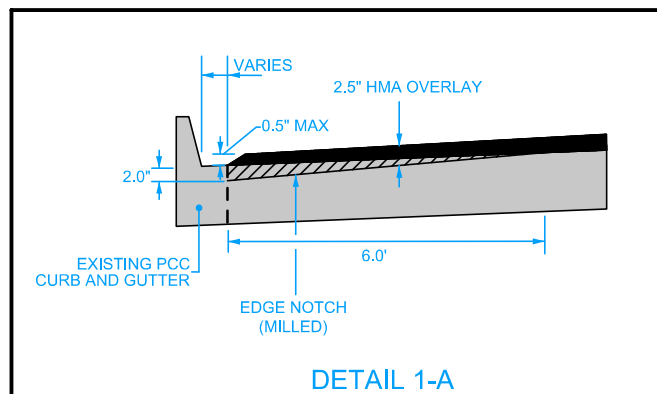

ROAD IDENTIFICATION	BEGIN STATION	END STATION	LW Feet	RW Feet	SC Inch	IB Inch
SOUTH 14TH AVENUE	180+34.56	189+71.44	12.0	12.0	1.5	1.0
SOUTH 16TH AVENUE	190+33.62	193+46.02	12.0	12.0	1.5	1.0
NORRIS PLACE	260+00.00	262+98.66	12.0	12.0	1.5	1.0
SOUTH 17TH AVENUE	200+00.00	207+91.20	12.0	12.0	1.5	1.0

**TYPICAL CROSS SECTION
HMA OVERLAY WITH MILLED GUTTER NOTCHES**

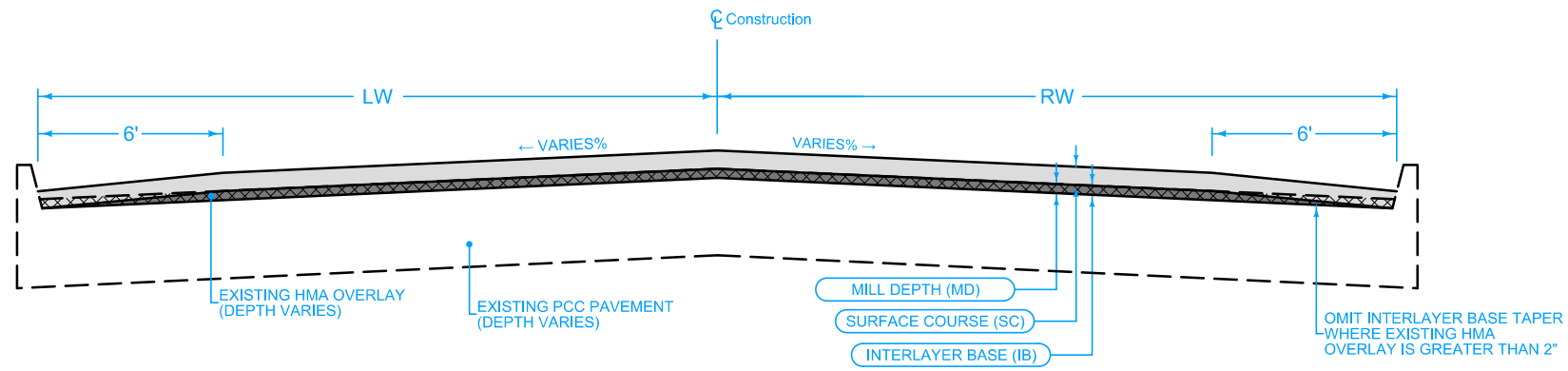

ROAD IDENTIFICATION	BEGIN STATION	END STATION	LW Feet	RW Feet	MD Inch	SC Inch	IB Inch
NORTH 2ND STREET	100+64.26	114+41.15	15.0	15.0	1.0	1.5	1.0
WEST WEBSTER STREET	120+24.92	128+65.94	15.0	15.0	1.0	1.5	1.0
WEST GRANT STREET	130+34.96	134+43.86	15.0	15.0	1.0	1.5	1.0
WEST GRANT STREET	134+43.86	139+42.51	21.0	21.0	1.0	1.5	1.0
WEST LINN STREET	140+54.80	144+05.51	12.0	12.0	3.0	2.0	1.0
WEST LINN STREET	144+05.51	148+53.16	15.0	15.0	3.0	2.0	1.0
SOUTH 1ST STREET	150+59.62	154+12.88	12.0	16.0	3.0	2.0	1.0
SOUTH 1ST STREET	154+29.41	158+50.13	25.0	25.0	3.0	2.0	1.0
EAST BOONE STREET	160+00.00	164+52.82	12.0	12.0	3.0	2.0	1.0
EAST BOONE STREET	165+19.47	169+89.21	12.0	12.0	3.0	2.0	1.0
WEST STATE STREET	220+29.59	225+84.79	18.0	18.0	3.0	2.0	1.0
WEST STATE STREET	225+84.79	230+43.33	27.0	27.0	3.0	2.0	1.0
WEST STATE STREET	230+43.33	256+65.87	15.0	15.0	3.0	2.0	1.0
SOUTH 1ST AVE	418+51.32	430+77.75	12.0	12.0	2.0	1.5	1.0

**TYPICAL CROSS SECTION
COMPOSITE PAVEMENT MILL AND OVERLAY**

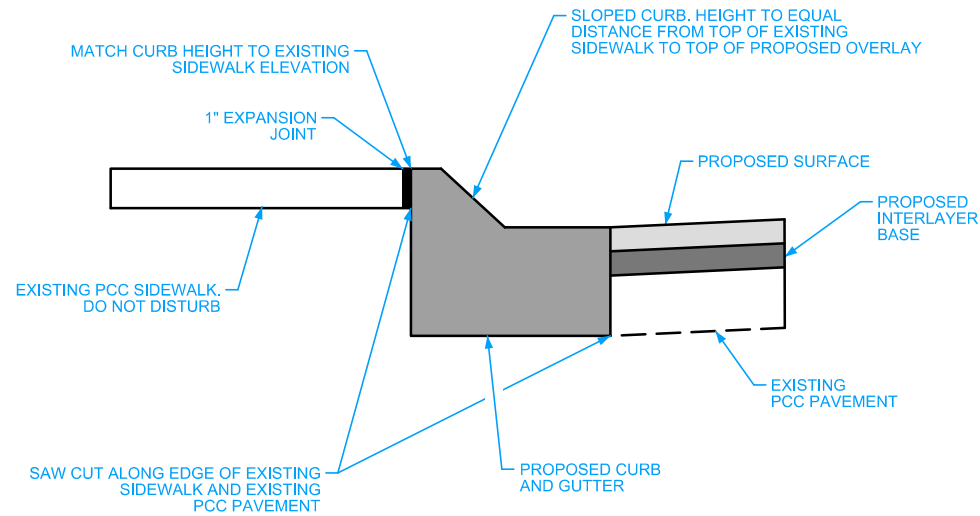

**PCC SLOPED CURB AND GUTTER
REPLACEMENT ALONG 1ST STREET**

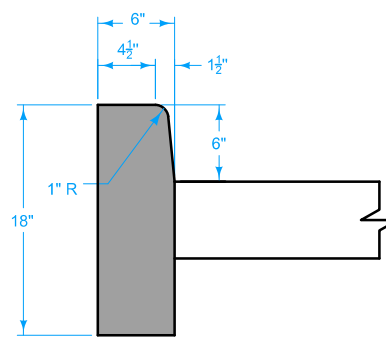

BEAM CURB*
***For short replacement sections,
match existing curb profile**

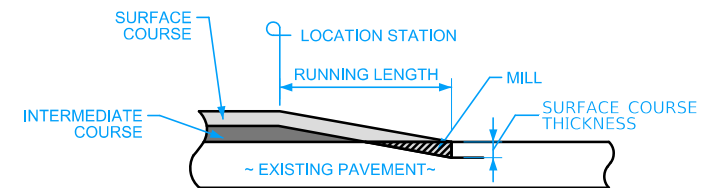

MILLED SURFACE NOTCH RUNOUT

DRAWN BY: RJY JOB DATE: May 4, 2026 CAD DATE: 5/4/2026 4:44:39 PM
APPROVED: CJ JOB NUMBER: 2602496 rtyrrel

NO.	DATE	BY	REVISION DESCRIPTION



2026 Street Rehabilitation
City of Marshalltown

Typical Sections

SHEET NO.
B.3

ESTIMATED PROJECT QUANTITIES

Item No.	Item Code	Item	Unit	Total	As Built Qty.
1	2010-D-3	TOPSOIL, OFF-SITE	CY	94	
2	2010-I	SUBGRADE TREATMENT, GEOGRID, TYPE 4	SY	433	
3	5020-F	VALVE BOX ADJUSTMENT, MINOR	EA	9	
4	6010-E-1	MANHOLE ADJUSTMENT, MINOR	EA	29	
5	7010-E	CURB AND GUTTER, 2.5 FT	LF	1229	
6	7010-F	BEAM CURB	LF	239	
7	7020-A	PAVEMENT, ASPHALT, STANDARD TRAFFIC, BASE, 3/4", PG 58-28S	TON	78	
8	7020-A	PAVEMENT, ASPHALT, STANDARD TRAFFIC, INTERMEDIATE, 1/2", PG 58-28S	TON	39	
9	7020-I	ASPHALT PAVEMENT SAMPLES AND TESTING	LS	1	
10	7021-A	ASPHALT OVERLAY, INTERLAYER BASE, 3/8", PG 58-34E	TON	3611	
11	7021-A	ASPHALT OVERLAY, SURFACE, 1/2", PG 58-28S	TON	6319	
12	7040-B	SUBBASE OVER-EXCAVATION	TON	124	
13	7040-G	MILLING	SY	48138	
14	7040-I	CURB AND GUTTER REMOVAL	LF	1468	
15	7999-A	CLEANING AND PREPARATION OF BASE	MILE	3.29	
16	7999-B	PARTIAL DEPTH PATCHES, HMA	TON	430	
17	8030-A	TEMPORARY TRAFFIC CONTROL	LS	1	
18	9010-A	CONVENTIONAL SEEDING, FERTILIZING, AND MULCHING, TYPE 1	AC	0.2	
19	11020-A	MOBILIZATION	LS	1	
		ADD ALETERNATES			
20	5020-F	VALVE BOX ADJUSTMENT, MINOR	EA	1	
21	6010-E-1	MANHOLE ADJUSTMENT, MINOR	EA	5	
22	7010-E	CURB AND GUTTER, 2.5 FT	LF	112	
23	7021-A	ASPHALT OVERLAY, INTERLAYER BASE, 3/8", PG 58-34E	TON	238	
24	7021-A	ASPHALT OVERLAY, SURFACE, 1/2", PG 58-28S, STANDARD TRAFFIC	TON	362	
25	7040-G	MILLING	SY	2136	
26	7040-I	CURB AND GUTTER REMOVAL	LF	112	
27	7999-A	CLEANING AND PREPARATION OF BASE	MILE	0.27	
28	7999-B	PARTIAL DEPTH PATCHES, HMA	TON	35	

ESTIMATE REFERENCE INFORMATION

Item No.	Item Code	Description
1	2010-D-3	TOPSOIL, OFF-SITE A. STRIPPING AND REMOVAL OF EXISTING ON-SITE TOPSOIL SHALL BE INCIDENTAL TO THIS ITEM. B. SUITABLE ON-SITE TOPSOIL MAY BE USED. TESTING OF TOPSOIL REQUIRED TO ENSURE REQUIREMENTS ARE MET. C. TOPSOIL SHALL BE RESPREAD OVER DISTURBED AREAS TO 8" THICKNESS. BID QUANTITY INCLUDES 35% SHRINKAGE.
2	2010-I	SUBGRADE TREATMENT, GEOGRID, TYPE 4 A. REFER TO TYPICAL SECTIONS IN B SHEETS. B. GEOGRID SHALL BE MULTIAXIAL MEETING SUDAS STANDARD SPECIFICATIONS 2010, 2.04, C, 5, TYPE 4.
3	5020-F	VALVE BOX ADJUSTMENT, MINOR A. ITEM INCLUDES MINOR ADJUSTMENTS OF EXISTING VALVE BOXES BY RAISING OR LOWERING ADJUSTABLE VALVE BOX.
4	6010-E-1	MANHOLE ADJUSTMENT, MINOR A. REFER TO D SHEETS FOR LOCATIONS AND INFORMATION. B. ADJUSTMENT RISERS SHALL BE USED TO ADJUST MANHOLE HEIGHT.
5	7010-E	CURB AND GUTTER, 2.5 FT
6	7010-F	BEAM CURB A. REFER TO C SHEETS AND D SHEETS FOR LOCATIONS AND INFORMATION. B. MATCH EXISTING CURB PROFILE. REFER TO SUDAS FIGURES 7010.102. C. FOR CURB AND GUTTER SECTIONS, INCREASE APRON DEPTH OF CURB AND GUTTER TO MATCH THE BASE OF EXISTING PAVEMENT OR 7 INCH THICKNESS, WHICHEVER IS GREATER. ADDITIONAL PAVEMENT FOR THICKNESSES GREATER THAN 7 INCHES IS INCIDENTAL. D. BEAM CURBS SHALL BE INSTALLED TO A DEPTH OF 18" OR ADJACENT CURB DEPTH, WHICHEVER IS GREATER. CURB SHALL BE TIED ON BOTH ENDS TO EXISTING CURBS IF CONDITIONS ALLOW. E. SUBGRADE PREPARATION IN LOCATIONS OF NEW CURB AND GUTTER IS INCIDENTAL TO THIS ITEM. SUBGRADE CAN BE COMPACTED WITHOUT SCARIFICATION. USE APPROPRIATE EQUIPMENT TO PREPARE THE SUBGRADE FOR TYPE 'A' COMPACTION.

ESTIMATE REFERENCE INFORMATION

Item No.	Item Code	Description
7	7020-A	PAVEMENT, ASPHALT, STANDARD TRAFFIC, BASE, 3/4", PG 58-28S
8	7020-A	PAVEMENT, ASPHALT, STANDARD TRAFFIC, INTERMEDIATE, 1/2", PG 58-28S
9	7020-I	ASPHALT PAVEMENT SAMPLES AND TESTING
10	7021-A	ASPHALT OVERLAY, INTERLAYER BASE, 3/8", PG 58-34E
11	7021-A	ASPHALT OVERLAY, SURFACE, 1/2", PG 58-28S, STANDARD TRAFFIC A. REFER TO TYPICAL SECTIONS IN B SHEETS. B. REFER TO C SHEETS AND D SHEETS FOR LOCATIONS AND INFORMATION. C. REFER TO SUDAS STANDARD SPECIFICATIONS 7021, 2.04, B FOR ASPHALT INTERLAYER.
12	7040-B	SUBBASE OVER-EXCAVATION A. REFER TO B SHEETS. B. REMOVE EXISTING SUBBASE OR SUBGRADE TO A DEPTH OF 6" BELOW THE BOTTOM OF PROPOSED PAVEMENT SURFACE. C. RECYCLED/CRUSHED ASPHALT PAVEMENT MAY BE USED AS SUBBASE MATERIAL.
13	7040-G	MILLING A. REFER TO B SHEET TYPICALS, CORING SUMMARY TABLE IN THE C SHEETS, AND D SHEETS FOR ADDITIONAL INFORMATION AND MILLING LOCATIONS. B. MILLING THICKNESS VARIES BETWEEN 1 TO 6 INCHES, REFER TO TABULATIONS IN THE C SHEETS. C. ITEM INCLUDES MILLED SURFACE NOTCHES FOR RUNOUT AND EXISTING PCC CURB AND GUTTER LOCATIONS, REFER TO SUDAS STANDARD SPECIFICATIONS FIGURE 7021.101 FOR DETAILS. D. ADJUST MILLING DEPTH TO NOT DISTURB THE UNDERLYING BASE PAVEMENT OR SUBGRADE. E. ASPHALT MILLINGS TO BECOME PROPERTY OF CONTRACTOR FOR DISPOSAL.
14	7040-I	CURB AND GUTTER REMOVAL A. REFER TO C SHEETS AND D SHEETS FOR LOCATIONS AND INFORMATION. B. SAW CUTTING, INCLUDING ANY CUTS ALONG BACK OF CURB, SHALL BE INCIDENTAL TO THIS ITEM. C. EARTHWORK REQUIRED FOR CURB REPLACEMENT WILL NOT BE MEASURED AND SHALL BE INCIDENTAL TO THIS ITEM.
15	7999-A	CLEANING AND PREPARATION OF BASE A. REFER TO AND APPLY IOWA DOT STANDARD SPECIFICATIONS SECTION 2212.03, B, 1.
16	7999-B	PARTIAL DEPTH PATCHES, HMA A. REFER TO C SHEETS FOR INFORMATION. B. REFER TO AND APPLY SUDAS STANDARD SPECIFICATIONS SECTION 7040, 1.08, C. C. ITEM TO BE MEASURED AND PAID BY TONS OF ASPHALT MATERIAL PLACED. D. QUANTITY IS ESTIMATED. PRIOR AUTHORIZATION FROM ENGINEER OR CITY REPRESENTATIVE IS REQUIRED PRIOR TO PERFORMING WORK.
17	8030-A	TEMPORARY TRAFFIC CONTROL A. TRAFFIC CONTROL SHALL COMPLY WITH THE LATEST VERSION OF THE MUTCD. B. REFER TO SUDAS STANDARD FIGURE 8030.116 FOR ROAD CLOSURES. C. BARRICADES SHALL BE REMOVED DURING NON-WORKING HOURS OR WHEN WORKERS ARE NOT PRESENT, PROVIDED THAT NO HAZARD EXISTS AND THE AREA IS SAFE FOR TRAFFIC. D. CONTRACTOR TO GIVE ADJACENT PROPERTY OWNERS AT LEAST 48 HOURS NOTICE PRIOR TO THE START OF WORK TO AVOID ACCESSIBILITY CONFLICTS.
18	9010-A	CONVENTIONAL SEEDING, FERTILIZING, AND MULCHING, TYPE 1
19	11020-A	MOBILIZATION ADD ALTERNATES. REFER TO BASE BID ERI NOTES. ADDITIONS/CHANGES ARE LISTED BELOW.
20	5020-F	VALVE BOX ADJUSTMENT, MINOR
21	6010-E-1	MANHOLE ADJUSTMENT, MINOR
22	7010-E	CURB AND GUTTER, 2.5 FT
23	7021-A	ASPHALT OVERLAY, INTERLAYER BASE, 3/8", PG 58-34E
24	7021-A	ASPHALT OVERLAY, SURFACE, 1/2", PG 58-28S, STANDARD TRAFFIC
25	7040-G	MILLING
26	7040-I	CURB AND GUTTER REMOVAL
27	7999-A	CLEANING AND PREPARATION OF BASE
28	7999-B	PARTIAL DEPTH PATCHES, HMA

HMA PAVEMENT

Calculations assume a surface and intermediate course unit weight (lbs/cf) of 147 and a base course unit weight (lbs/cf) of 145 with a 10% factor included for additional quantity allowance

Location				Mainline				Total Area		HMA Pavement Surface		HMA Pavement Interlayer Base		HMA Base Course		HMA Intermediate Course		Binder Surface	Binder Interlayer Base	Milling			Partial Depth Patches	Remarks	
Road Identification	Direction of Travel	Station to Station		Width	Length	Area	SY	SY	Thickness	TONS	Thickness	TONS	Thickness	TONS	Thickness	TONS	TONS	TONS	Thickness	Width	Area	TON			
									IN		IN		IN		IN	FT			SY						
				FT	FT	SY	SY	IN		IN		IN		IN		TONS	TONS	IN	FT	SY	TON				
N 2ND STREET	N/S	100+64.26	114+41.15	30.0	1376.89	4589.6	4590.7	1.5	417.6	1.0	274.6					27.6	18.1	1.0	30.0	4590.7	35.0				
W WEBSTER STREET	E/W	120+24.92	128+65.94	30.0	841.0	2803.4	2840.2	1.5	258.3	1.0	169.9					17.0	11.2	1.0	30.0	2840.2	20.0				
W GRANT STREET	E/W	130+34.96	134+43.86	30.0	408.9	1363.0	1519.4	1.5	138.2	1.0	90.9					9.1	6.0	1.0	30.0	1519.4	10.0				
W GRANT STREET	E/W	134+43.86	139+42.51	42.0	498.7	2327.0	2496.1	1.5	227.0	1.0	149.3					15.0	9.9	1.0	42.0	2496.1	10.0				
W LINN STREET	E/W	140+54.80	144+05.51	24.0	350.7	935.2	938.6	2.0	113.8	1.0	56.1					7.5	3.7	3.0	24.0	938.6	10.0				
W LINN STREET	E/W	144+05.51	148+53.16	30.0	447.7	1492.2	1427.4	2.0	173.1	1.0	85.4					11.4	5.6	3.0	30.0	1427.4	10.0				
S 1ST STREET	N/S	150+59.62	154+12.88	28.0	353.3	1099.0	1056.2	2.0	128.1	1.0	63.2					8.5	4.2	3.0	28.0	1056.2	10.0				
S 1ST STREET	N/S	154+29.41	158+50.13	50.0	420.7	2337.3	2399.4	2.0	291.0	1.0	143.5					19.2	9.5	3.0	50.0	2399.4	10.0				
E BOONE STREET	E/W	160+00.00	164+52.82	24.0	452.8	1207.5	1207.5	2.0	146.4	1.0	72.2					9.7	4.8	3.0	24.0	1207.5	10.0				
E BOONE STREET	E/W	165+19.47	169+89.21	24.0	469.7	1252.6	1203.7	2.0	146.0	1.0	72.0					9.6	4.8	3.0	24.0	1203.7	10.0				
S 14TH STREET	N/S	180+34.56	189+71.44	20.0	936.9	2082.0	2643.2	1.5	240.4	1.0	158.1					15.9	10.4	2.0	20.0	1338.1	25.0	Milled Notches			
S 16TH STREET	N/S	190+33.62	193+46.02	20.0	312.4	694.2	662.4	1.5	60.3	1.0	39.6					4.0	2.6	2.0	20.0	505.4	10.0	Milled Notches, Add Alternate			
NORRIS PLACE	E/W	260+00.00	262+98.66	20.0	298.7	663.7	887.2	1.5	80.7	1.0	53.1					5.3	3.5	2.0	20.0	487.1	5.0	Milled Notches, Add Alternate			
S 17TH STREET	N/S	200+00.00	207+91.20	20.0	791.2	1758.2	2182.3	1.5	198.5	1.0	130.5					13.1	8.6	2.0	20.0	1143.8	20.0	Milled Notches, Add Alternate			
W STATE STREET	E/W	220+29.59	225+84.79	36.0	555.2	2220.8	2082.4	2.0	252.5	1.0	124.6					16.7	8.2	3.0	36.0	2082.4	15.0				
W STATE STREET	E/W	225+84.79	230+43.33	54.0	458.5	2751.2	2498.3	2.0	303.0	1.0	149.4					20.0	9.9	3.0	54.0	2498.3	10.0				
W STATE STREET	E/W	230+43.33	256+65.87	30.0	2622.5	8741.8	8741.8	2.0	1060.2	1.0	522.9					70.0	34.5	3.0	30.0	8741.8	65.0				
W INGLEDUE STREET	E/W	300+41.43	307+61.79	26.0	720.4	2081.0	2081.0	1.5	189.3	1.0	124.5					12.5	8.2	2.0	0.0	1076.0	20.0	Milled Notches			
W INGLEDUE STREET	E/W	308+81.99	318+35.62	30.0	953.6	3178.8	2755.2	2.0	334.1	1.0	164.8					22.1	10.9	1.5	30.0	2755.2	25.0				
W INGLEDUE STREET	E/W	318+35.62	325+60.91	26.0	725.3	2095.3	2441.8	1.5	222.1	1.0	146.1					14.7	9.6	2.0	0.0	1082.6	20.0	Milled Notches			
S 3RD STREET	N/S	330+34.65	334+29.80	26.0	395.2	1141.5	1214.4	1.5	110.5	1.0	72.6					7.3	4.8	2.0	0.0	642.4	10.0	Milled Notches			
W FERNER STREET	E/W	360+00.00	374+84.99	26.0	1485.0	4290.0	4549.9	1.5	413.8	1.0	272.1					27.3	18.0	2.0	0.0	2095.5	35.0	Milled Notches			
HIGHVIEW DRIVE	N/S	340+35.73	342+27.61	26.0	191.9	554.3	1171.4	1.5	106.5	1.0	70.1					7.0	4.6	2.0	0.0	371.4	5.0	Milled Notches			
S 1ST AVENUE	N/S	410+39.86	416+15.33	20.0	575.5	1278.8	1554.2	1.5	141.4	1.0	93.0					9.3	6.1	2.0	0.0	856.2	15.0	Milled Notches			
S 1ST AVENUE	N/S	416+34.94	418+15.32	20.0	180.4	FALSE	432.2	1.5	39.3						3.0	77.6	1.5	38.8	2.6	0.0	6.0	24.0	432.2	5.0	
S 1ST AVENUE	N/S	418+15.32	430+77.75	24.0	1262.4	3366.5	3479.6	1.5	316.5	1.0	208.1					20.9	13.7	2.0	24.0	3479.6	30.0				
E FERNER STREET	E/W	400+39.88	407+08.17	26.0	668.3	1930.6	1743.6	1.5	158.6	1.0	104.3					10.5	6.9	2.0	0.0	1006.6	15.0	Milled Notches			
TOTAL:								ASPHALT OVERLAY, INTERLAYER BASE, 3/8", PG 58-34E		3611.1	TONS											TOTAL:	48137.5	430.0	
								ASPHALT OVERLAY, SURFACE, 1/2", PG 58-28S		6319.0	TONS											ALTERNATE TOTAL:	2136.3	35.0	
								HMA BASE COURSE		77.6	TONS														
								HMA INTERMEDIATE COURSE		38.8	TONS														
								ADD ALTERNATES																	
								ASPHALT OVERLAY, INTERLAYER BASE, 3/8", PG 58-34E		237.9	TONS														
								ASPHALT OVERLAY, SURFACE, 1/2", PG 58-28S		361.8	TONS														

CORING SUMMARY

Street	Station	Offset	Core Thickness (in)	HMA Thickness (in)	PCC Thickness (in)	Remarks
North 2nd St	103+39.66	7.98	8.00	1.00	7.00	
North 2nd St	104+34.58	3.64	7.00	1.00	6.00	
North 2nd St	111+26.96	5.95	8.50	1.00	7.50	
West Ingledue St	300+94.45	4.40	3.50	3.50	0.00	
West Ingledue St	309+96.52	7.27	8.00	8.00	0.00	
West Ingledue St	320+10.41	10.81	4.25	4.25	0.00	
West Ferner St	366+67.50	3.18	5.75	5.75	0.00	
South 1st Ave	413+47.48	2.42	2.75	2.75	0.00	
South 1st Ave	417+71.42	-0.19	6.00	6.00	0.00	
South 1st Ave	424+94.08	16.94	8.00	1.75	6.25	
West State St	255+45.89	-6.99	5.00	5.00	0.00	
West State St	242+28.25	-8.31	12.00	4.00	8.00	
West State St	228+92.91	-6.80	9.50	3.00	6.50	
West Linn St	141+50.18	11.55	9.00	2.25	6.75	
West Linn St	146+48.67	11.86	10.00	4.00	6.00	
South 1st St	155+36.98	12.94	11.25	3.75	7.50	
South 1st St	157+71.64	-10.02	10.75	2.75	8.00	
South 1st St	151+83.56	0.33	9.00	3.00	6.00	
East Boone St	166+81.76	10.49	10.00	3.00	7.00	
South 14th Ave	182+64.58	-11.46	3.50	3.50	0.00	
South 16th Ave	191+40.79	5.08	5.00	5.00	0.00	
South 17th Ave	205+45.21	1.09	4.00	4.00	0.00	

CURB REPAIR

Street	Begin Station	End Station	Side	Length	Curb Type	Remarks
				LF		
West Webster St	121+18.81	121+30.92	RT	13.3	BEAM	
West Webster St	123+38.56	123+50.73	LT	13.4	BEAM	
West Grant St	133+56.50	133+73.21	RT	18.4	BEAM	
West Grant St	134+81.56	135+97.91	RT	128.0	BEAM	
West Grant St	137+06.57	137+66.51	LT	65.9	BEAM	
West Linn St	141+24.05	141+37.55	LT	14.9	STANDARD	
South 1st St	154+79.56	155+06.38	RT	29.5	STANDARD	
South 1st St	154+79.90	158+46.63	LT	403.4	SLOPED	
East Boone St	160+00.00	161+02.45	RT	112.7	STANDARD	
East Boone St	165+82.89	166+33.11	LT	55.2	STANDARD	
East Boone St	166+68.97	167+84.88	LT	127.5	STANDARD	
South 14th Ave	182+36.07	182+49.87	RT	15.2	STANDARD	
South 16th Ave	192+14.21	192+65.31	RT	56.2	STANDARD. ADD ALTERNATE	
Norris Pl	260+00.00	260+39.65	LT	56.0	STANDARD. ADD ALTERNATE	
West State St	220+74.51	222+78.37	LT	224.2	STANDARD	
West State St	223+34.08	223+48.36	LT	15.7	STANDARD	
West State St	225+01.87	225+54.39	LT	57.8	STANDARD	
West State St	231+09.64	231+31.23	LT	23.7	STANDARD	
West State St	238+54.23	238+99.47	LT	49.8	STANDARD	
West State St	256+04.54	256+18.19	RT	15.0	STANDARD	
West State St	256+09.48	256+31.66	LT	24.4	STANDARD	
South 1st Ave	429+11.98	429+25.62	LT	15.0	STANDARD	
South 1st Ave	429+75.75	429+98.54	LT	25.1	STANDARD	
South 1st Ave	430+64.72	430+83.11	LT	20.2	STANDARD	
				CURB AND GUTTER, 2.5 FT TOTAL	1229.3	
				BEAM CURB TOTAL	239.0	
				CURB AND GUTTER REMOVAL TOTAL	1468.3	
				ADD ALTERNATES		
				CURB AND GUTTER, 2.5 FT ALTERNATE TOTAL	112.2	
				CURB AND GUTTER REMOVAL ALTERNATE TOTAL	112.2	

MANHOLE ADJUSTMENTS

Street	Station	Offset	Type	Remarks
North 2nd St	102+21.63	0.00	Minor	
North 2nd St	103+23.18	0.00	Minor	
North 2nd St	106+49.96	0.00	Minor	
North 2nd St	110+95.01	0.00	Minor	
W Webster St	123+08.25	0.00	Minor	
W Webster St	127+18.65	0.00	Minor	
W Grant St	132+28.25	0.00	Minor	
W Grant St	136+70.95	0.00	Minor	
W Grant St	137+11.83	7.00	Minor	
E Boone St	164+46.49	0.00	Minor	
E Boone St	167+74.94	0.00	Minor	
S 14th St	181+85.43	0.00	Minor	
S 14th St	185+41.48	0.00	Minor	
S 14th St	188+30.93	0.00	Minor	
Norris Pl	261+18.97	0.00	Minor	Add Alternate
S 17th St	200+88.38	6.00	Minor	
S 17th St	201+93.04	0.00	Minor	
S 17th St	202+73.66	0.00	Minor	
S 17th St	205+62.33	0.00	Minor	
W Ingledue St	303+61.06	0.00	Minor	
W Ingledue St	306+16.41	0.00	Minor	
W Ingledue St	318+69.60	28.00	Minor	
W Ingledue St	318+95.80	-15.00	Minor	
W Ingledue St	322+40.26	-15.00	Minor	
S 3rd St	332+31.16	0.00	Minor	
W Ferner St	362+01.41	0.00	Minor	
W Ferner St	363+43.12	0.00	Minor	
W Ferner St	366+84.57	0.00	Minor	
W Ferner St	368+28.58	0.00	Minor	
W Ferner St	371+86.12	0.00	Minor	
S 1st Ave	412+95.58	0.00	Minor	
S 1st Ave	422+40.23	0.00	Minor	
S 1st Ave	425+78.68	0.00	Minor	
S 1st Ave	428+88.95	0.00	Minor	
			MANHOLE ADJUSTMENT, MINOR TOTAL:	29.00
			ADD ALTERNATES	
			MANHOLE ADJUSTMENT, MINOR TOTAL:	5.00



LEGEND	
	HMA OVERLAY/FILL
	FULL/PARTIAL DEPTH HMA MILLING
	HMA EDGE NOTCH MILLING
	EXISTING MANHOLE
	EXISTING WATER VALVE
	EXISTING STORM SEWER
	EXISTING SANITARY SEWER
	EXISTING PCC STRUCTURE

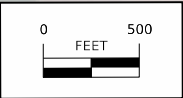

KEY MAP

DRAWN BY: RJY JOB DATE: May 4, 2026 CAD DATE: 5/1/2026 2:14:22 PM
 APPROVED: CJ JOB NUMBER: 2602496 rtyrrel

NO.	DATE	BY	REVISION DESCRIPTION



2026 Street Rehabilitation
 City of Marshalltown

Plan & Profile Sheets

SHEET NO.
D.1

\\hrgreen.com\HRG\Data\2026\2602496\CAD\Design\CADD_Sheet_LFiles\Sheet_LFiles\GHT_D02_2602496.dgn

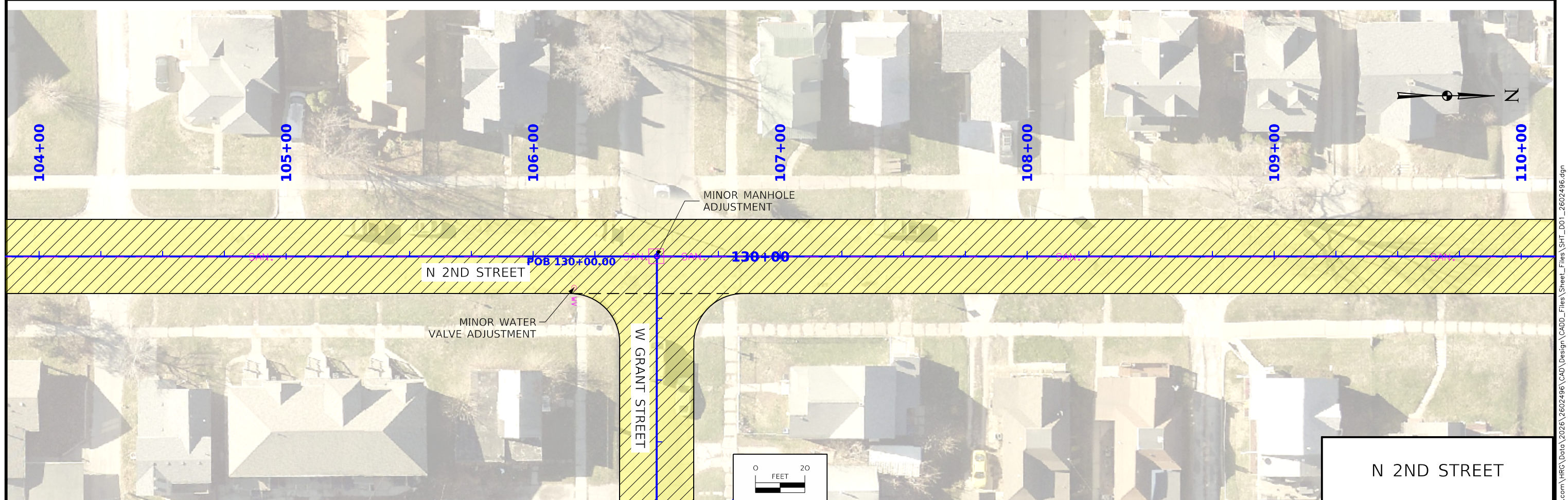
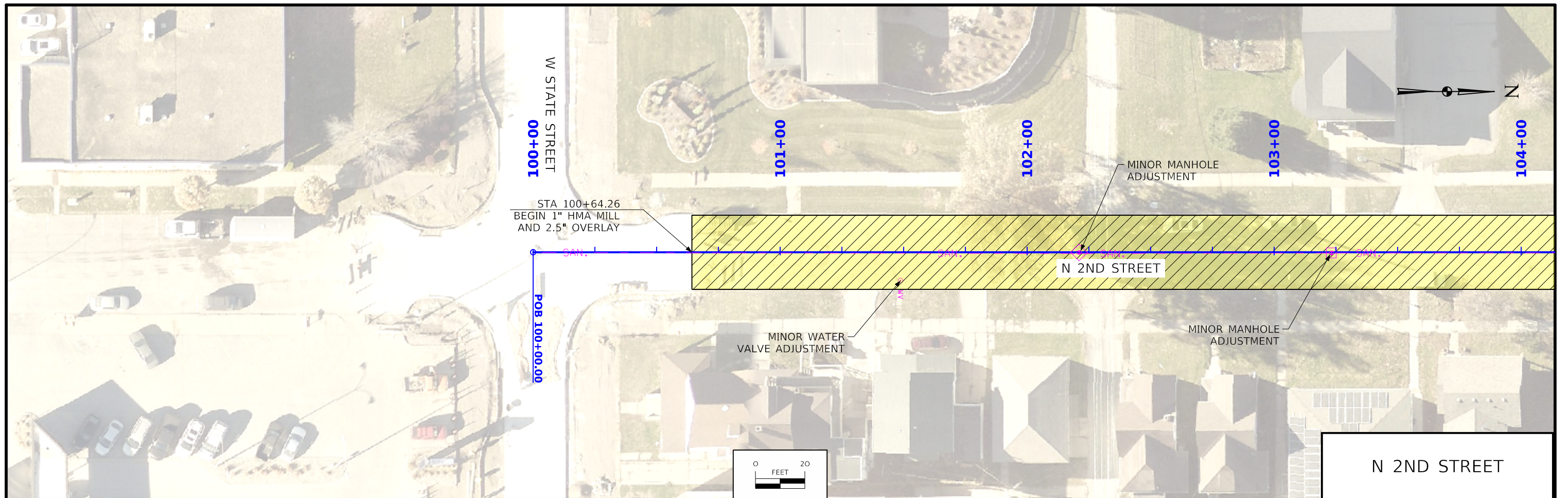

DRAWN BY: RJY JOB DATE: May 4, 2026 CAD DATE: 5/1/2026 2:14:30 PM
 APPROVED: CJ JOB NUMBER: 2602496 rtyrrel

NO.	DATE	BY	REVISION DESCRIPTION



2026 Street Rehabilitation
 City of Marshalltown

Plan & Profile Sheets

SHEET NO.
D.2

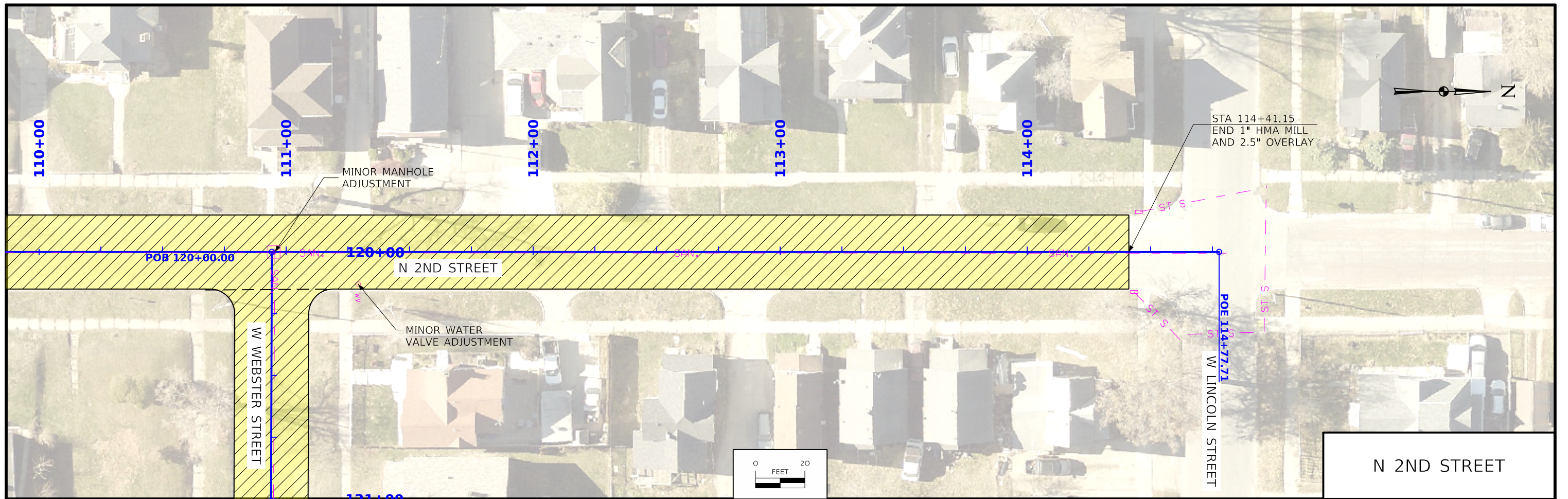

DRAWN BY: RJY JOB DATE: May 4, 2026 CAD DATE: 5/1/2026 2:14:31 PM
 APPROVED: CJ JOB NUMBER: 2602496 rtyrrel

NO.	DATE	BY	REVISION DESCRIPTION



2026 Street Rehabilitation
 City of Marshalltown

Plan & Profile Sheets

SHEET NO.
D.3

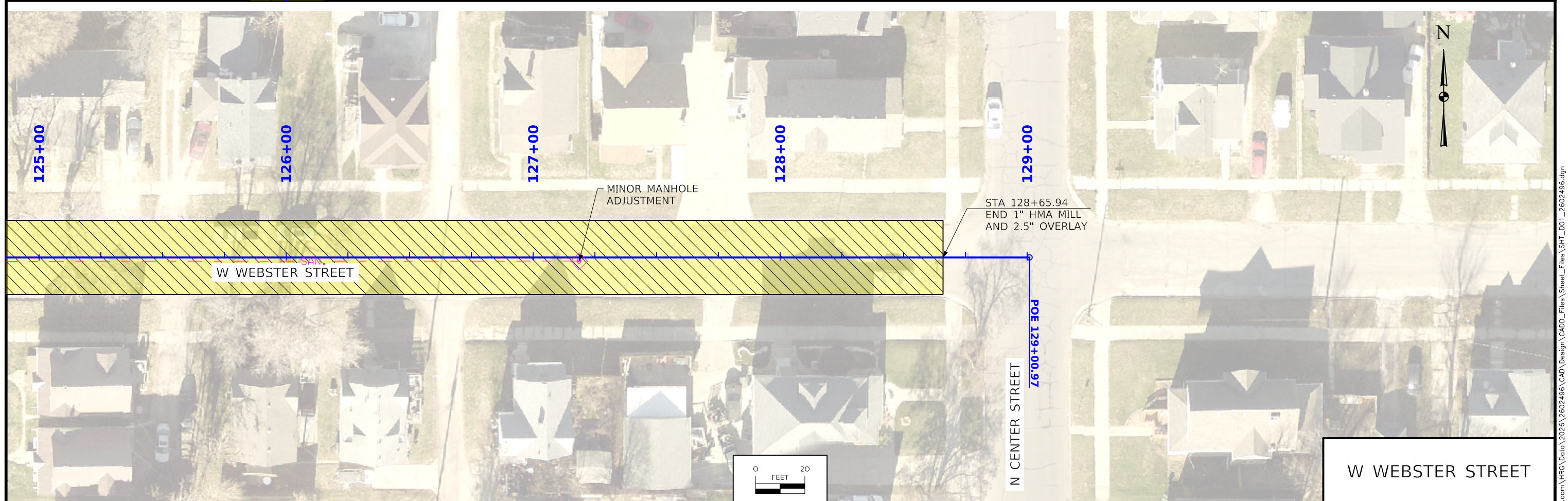
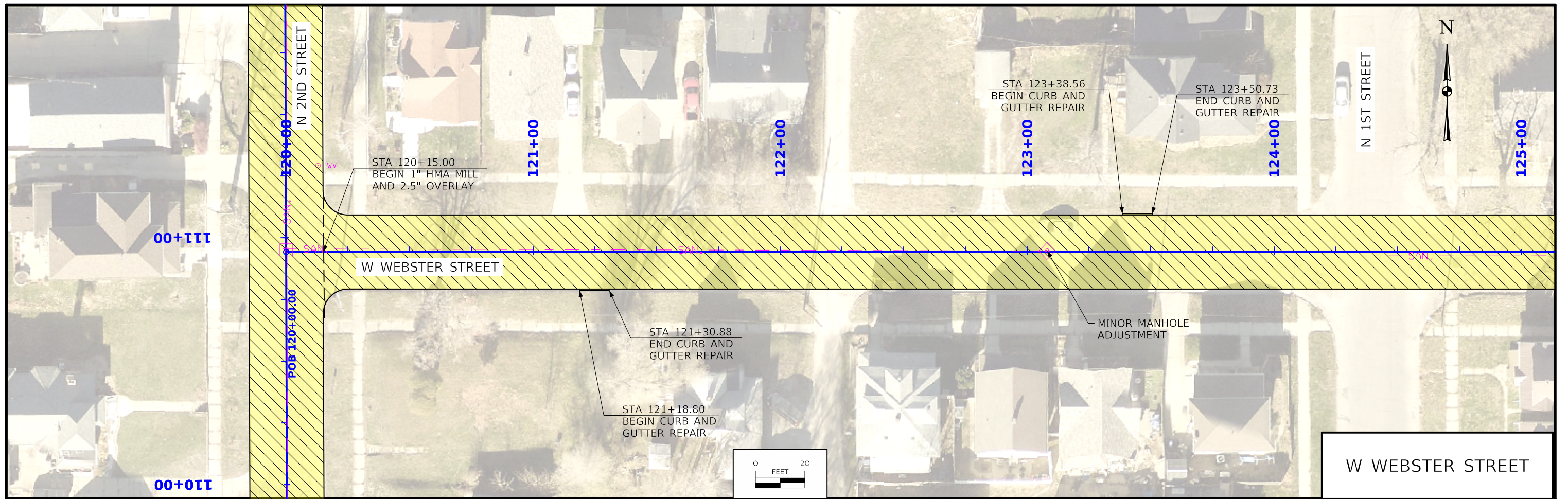

DRAWN BY: RJJ JOB DATE: May 4, 2026 CAD DATE: 5/1/2026 2:14:33 PM
 APPROVED: CJ JOB NUMBER: 2602496 rtyrrel

NO.	DATE	BY	REVISION DESCRIPTION



2026 Street Rehabilitation
 City of Marshalltown

Plan & Profile Sheets

SHEET NO.
D.4

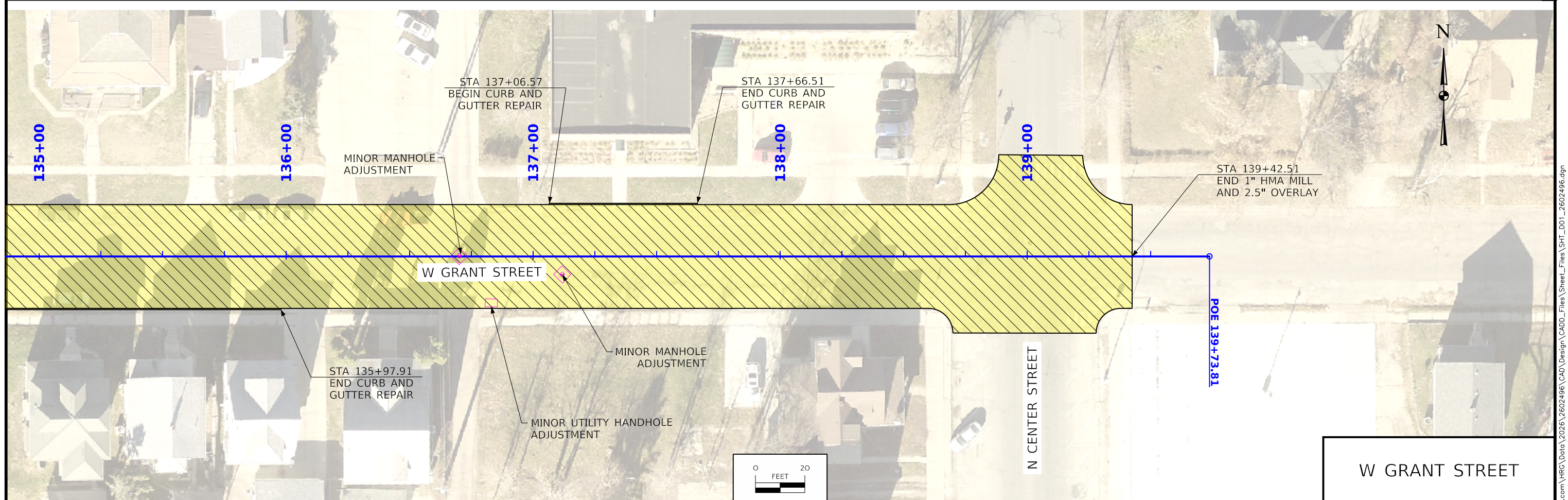
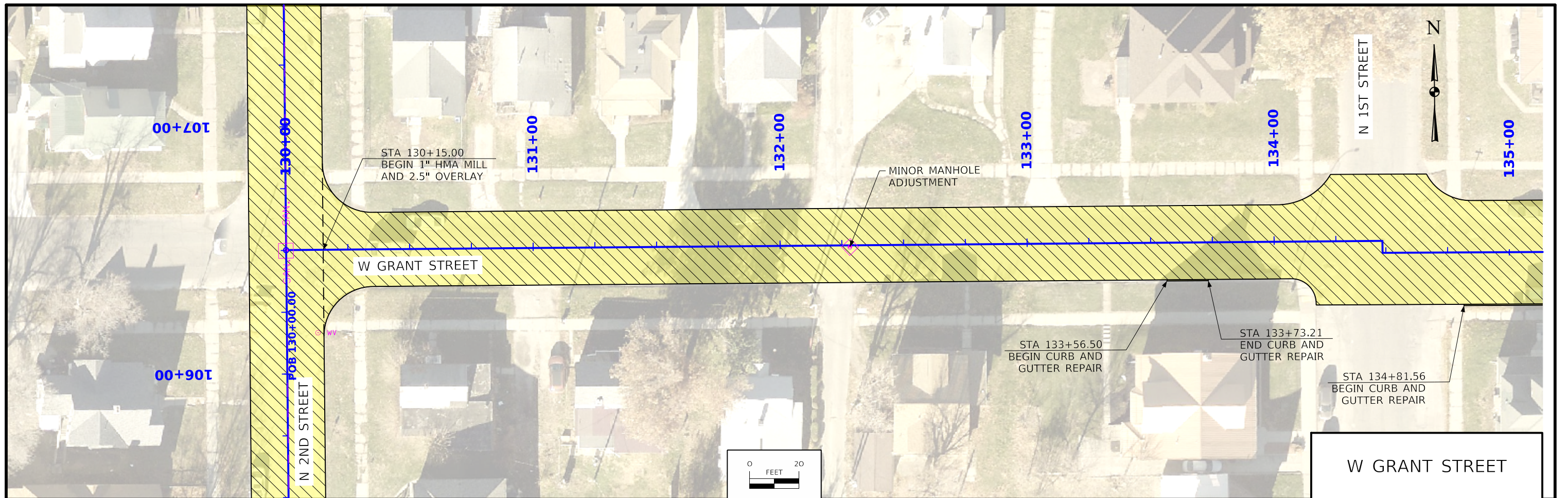

DRAWN BY: RJY JOB DATE: May 4, 2026 CAD DATE: 5/1/2026 2:14:34 PM
 APPROVED: CJ JOB NUMBER: 2602496 rtyrrel

NO.	DATE	BY	REVISION DESCRIPTION



2026 Street Rehabilitation
 City of Marshalltown

Plan & Profile Sheets

SHEET NO.
D.5

\\hrgreen.com\HRG\Data\2026\2602496\CAD\Design\CADD\Sheet_Files\Sheet_LFiles\GHT_D01_2602496.dgn

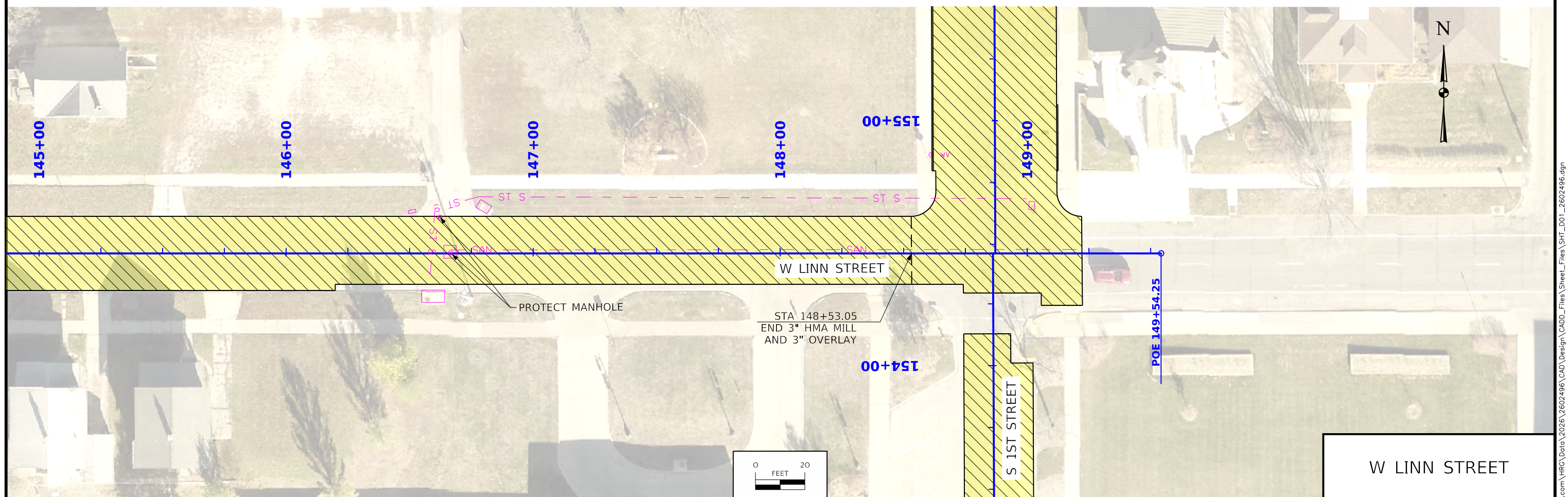
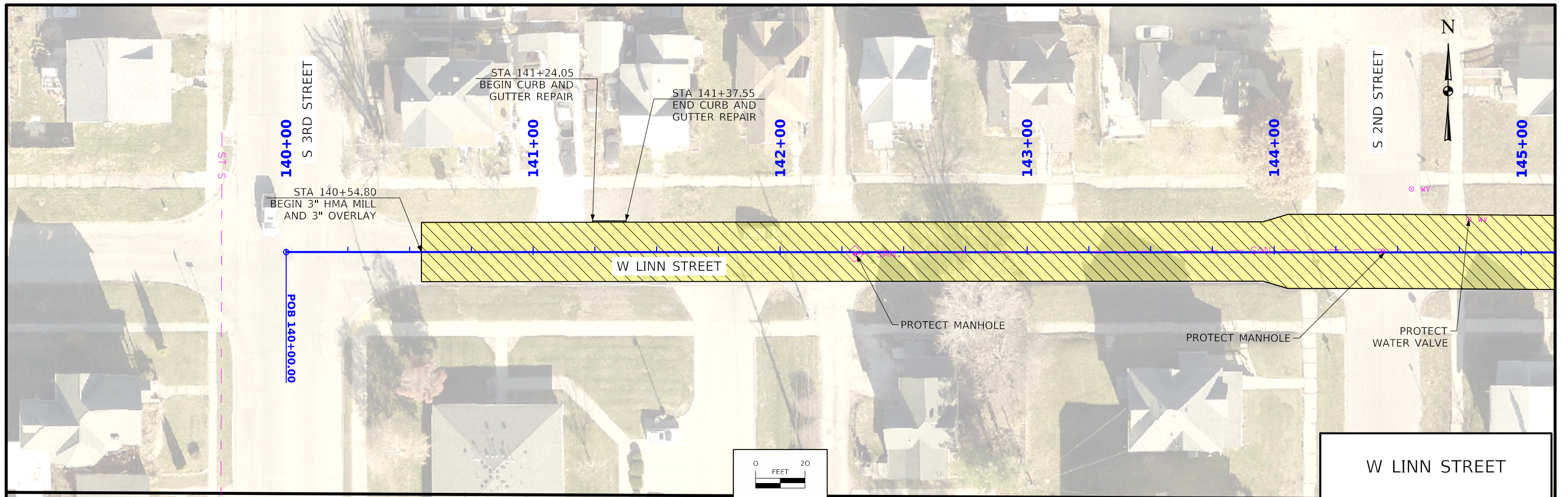

DRAWN BY: RJY JOB DATE: May 4, 2026 CAD DATE: 5/1/2026 2:14:35 PM
 APPROVED: CJ JOB NUMBER: 2602496 rtyrrel

NO.	DATE	BY	REVISION DESCRIPTION



2026 Street Rehabilitation
 City of Marshalltown

Plan & Profile Sheets

SHEET NO.
D.6

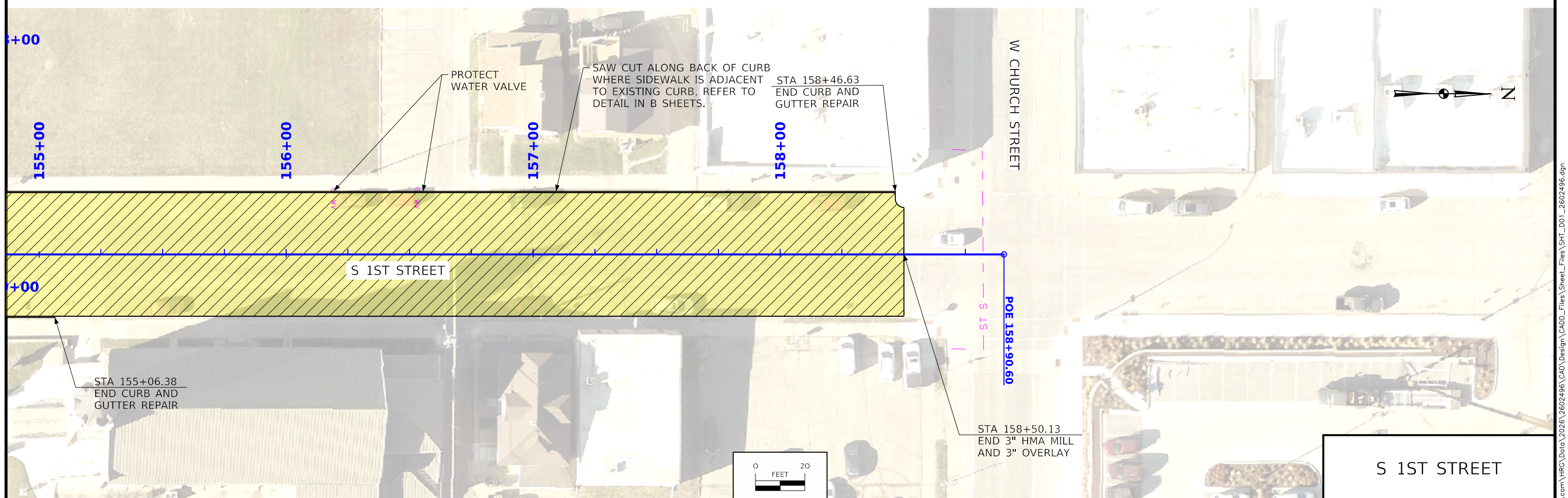
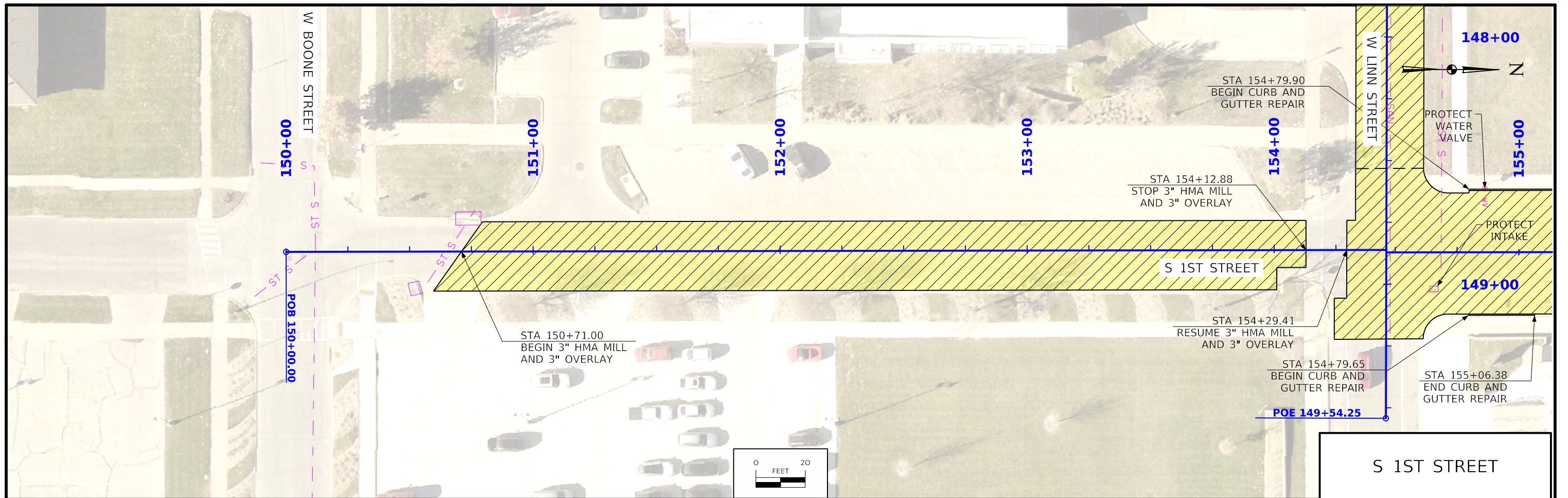

DRAWN BY: RJY JOB DATE: May 4, 2026 CAD DATE: 5/1/2026 2:14:37 PM
 APPROVED: CJ JOB NUMBER: 2602496 rtyrrel

NO.	DATE	BY	REVISION DESCRIPTION



2026 Street Rehabilitation
 City of Marshalltown

Plan & Profile Sheets

SHEET NO.
D.7

\\hrgreen.com\HRG\Data\2026\2602496\CAD\Design\CADD_Files\Sheet_CADD_Files\Sheet_SHT_D01_2602496.dgn

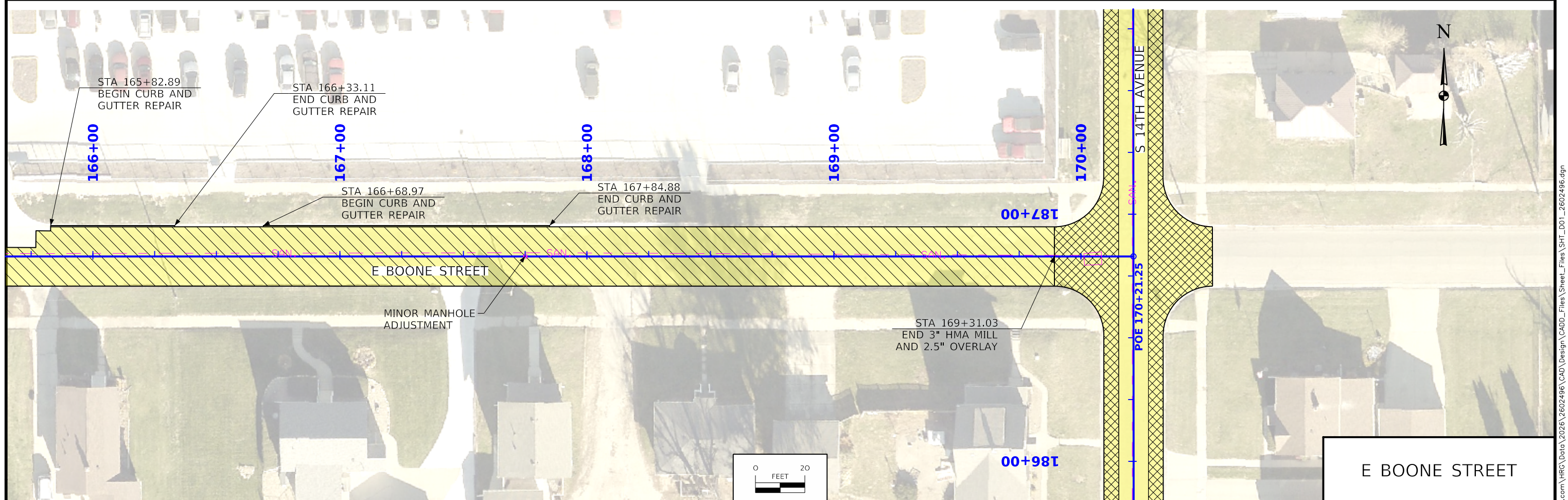
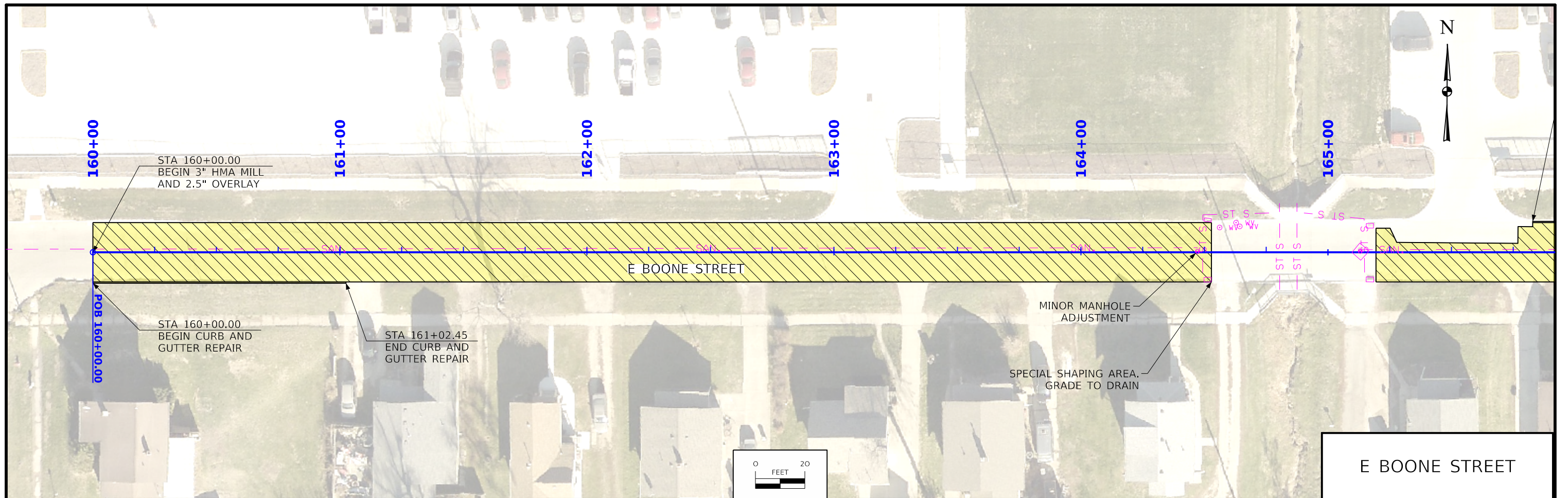

DRAWN BY: RJY JOB DATE: May 4, 2026 CAD DATE: 5/1/2026 2:14:39 PM
 APPROVED: CJ JOB NUMBER: 2602496 rtyrrel

NO.	DATE	BY	REVISION DESCRIPTION



2026 Street Rehabilitation
 City of Marshalltown

Plan & Profile Sheets

SHEET NO.
D.8

\\hrgreen.com\HRG\Data\2026\2602496\CAD\Design\CADD\Sheet_Lines\Sheet_Lines_SHT_D01_2602496.dgn

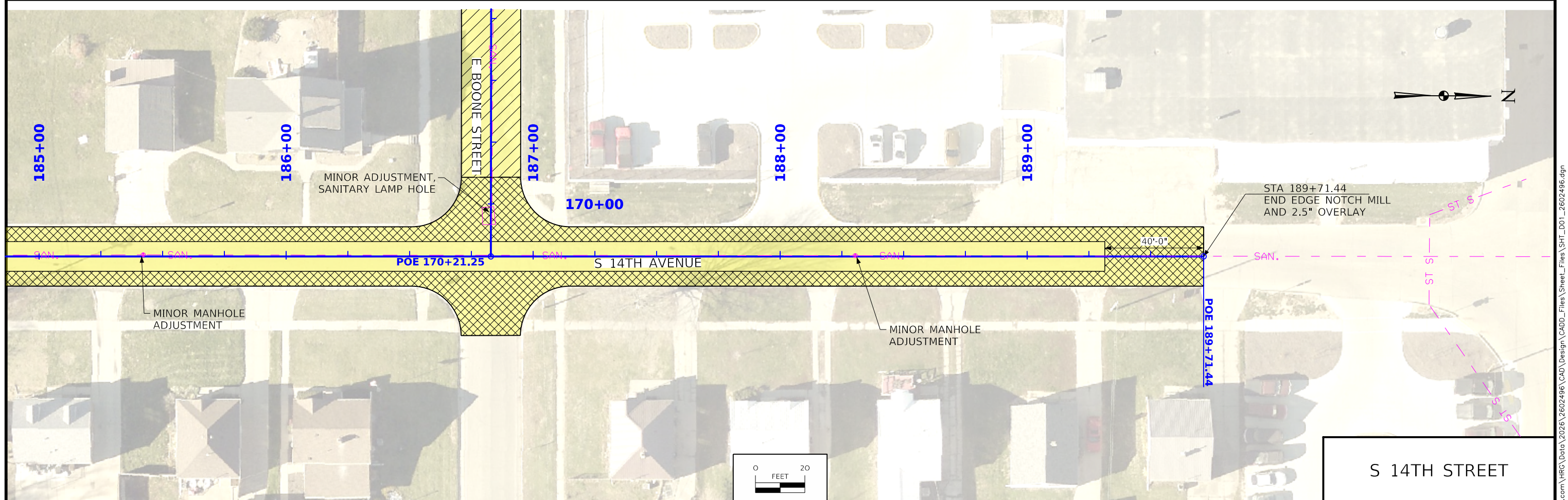
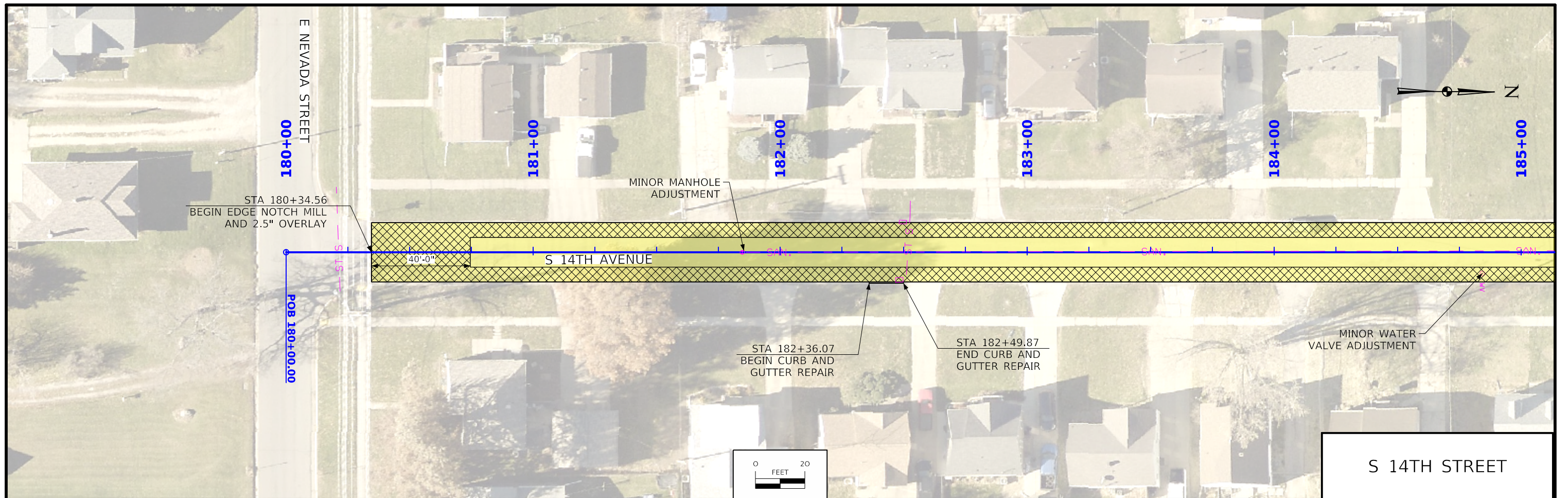

DRAWN BY: RJY JOB DATE: May 4, 2026 CAD DATE: 5/1/2026 2:14:40 PM
 APPROVED: CJ JOB NUMBER: 2602496 rtyrrel

NO.	DATE	BY	REVISION DESCRIPTION



2026 Street Rehabilitation
 City of Marshalltown

Plan & Profile Sheets

SHEET NO.
D.9

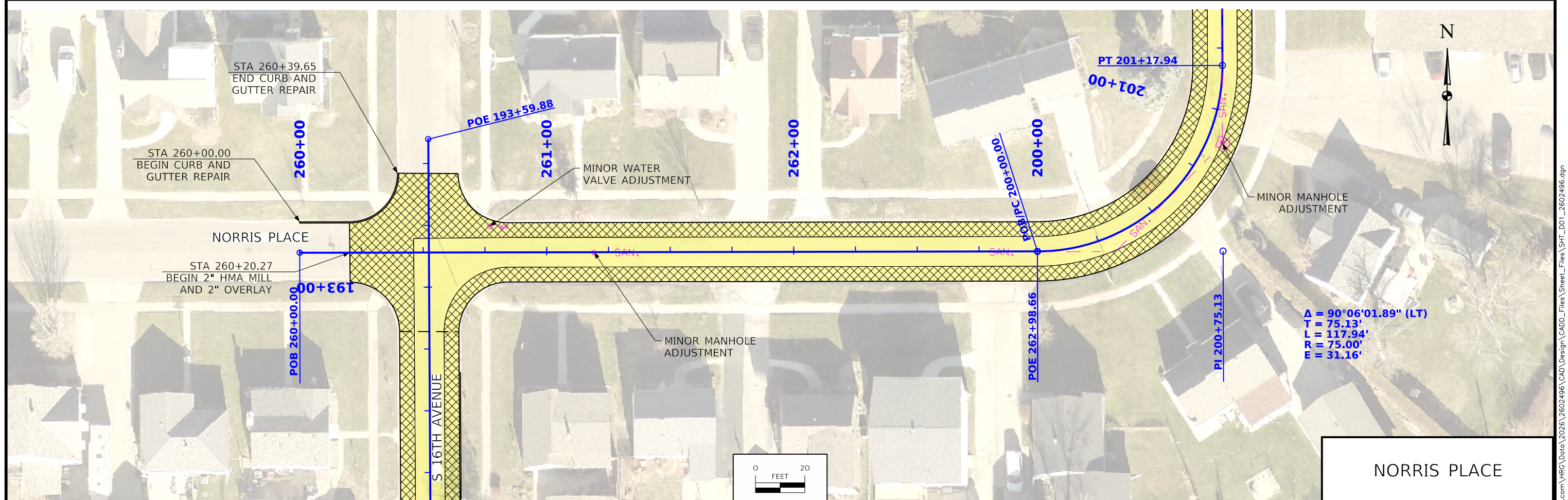
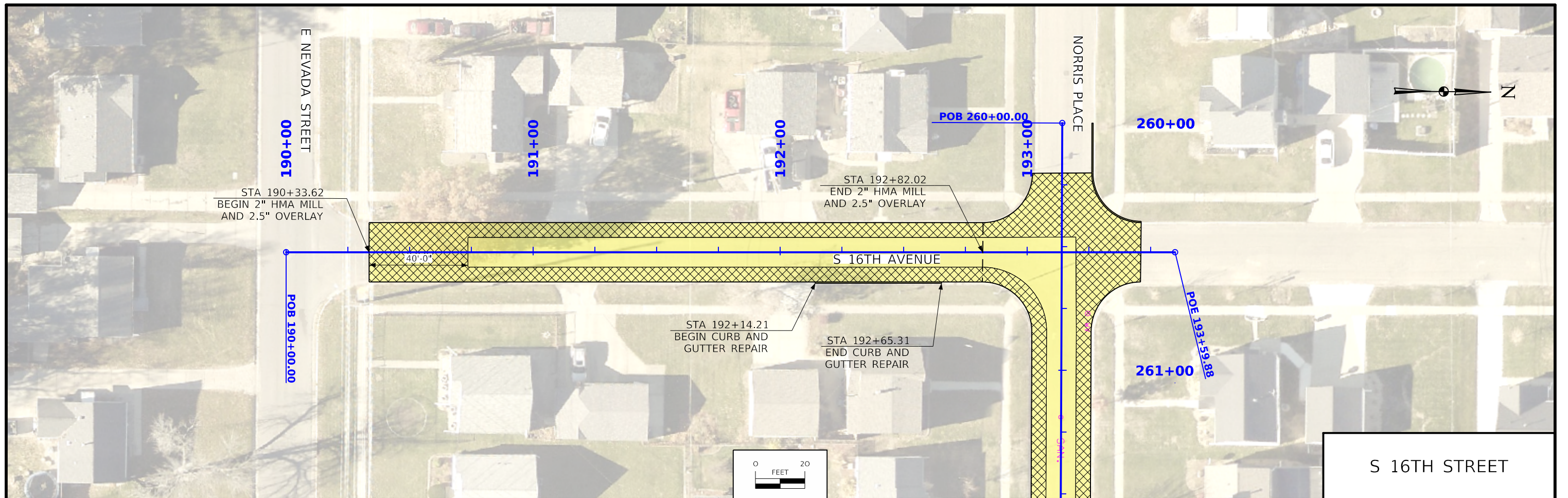

DRAWN BY: RJY JOB DATE: May 4, 2026 CAD DATE: 5/1/2026 2:14:42 PM
 APPROVED: CJ JOB NUMBER: 2602496 rtyrrel

NO.	DATE	BY	REVISION DESCRIPTION



2026 Street Rehabilitation
 City of Marshalltown

Plan & Profile Sheets

SHEET NO.
D.10

\\hrgreen.com\HRG\Data\2026\2602496\CAD\Design\CADD\Sheet_LFiles\Sheet_LFiles\GHT_D01_2602496.dgn

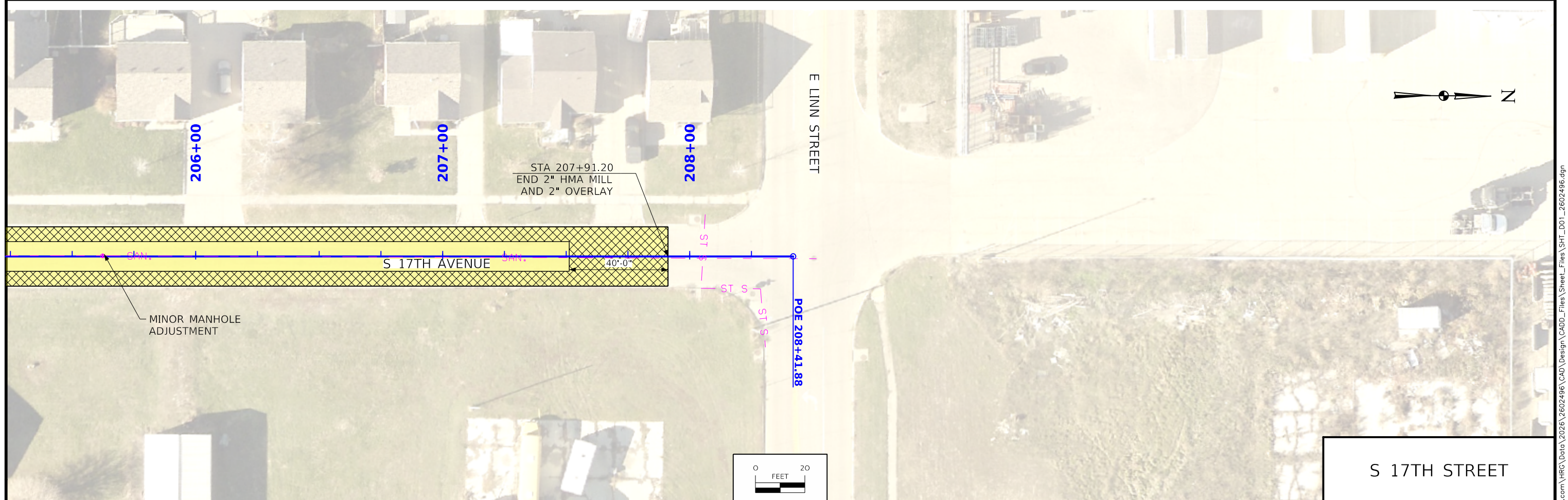
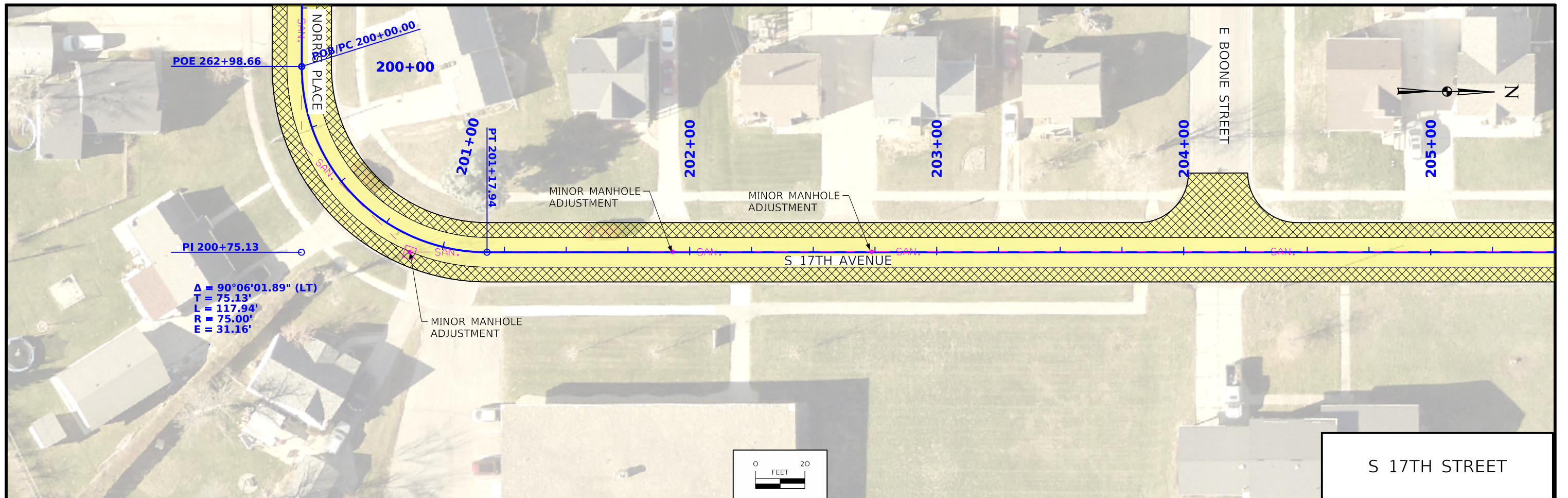

DRAWN BY: RJY JOB DATE: May 4, 2026 CAD DATE: 5/1/2026 2:14:43 PM
 APPROVED: CJ JOB NUMBER: 2602496 rtyrrel

NO.	DATE	BY	REVISION DESCRIPTION



2026 Street Rehabilitation
 City of Marshalltown

Plan & Profile Sheets

SHEET NO.
D.11

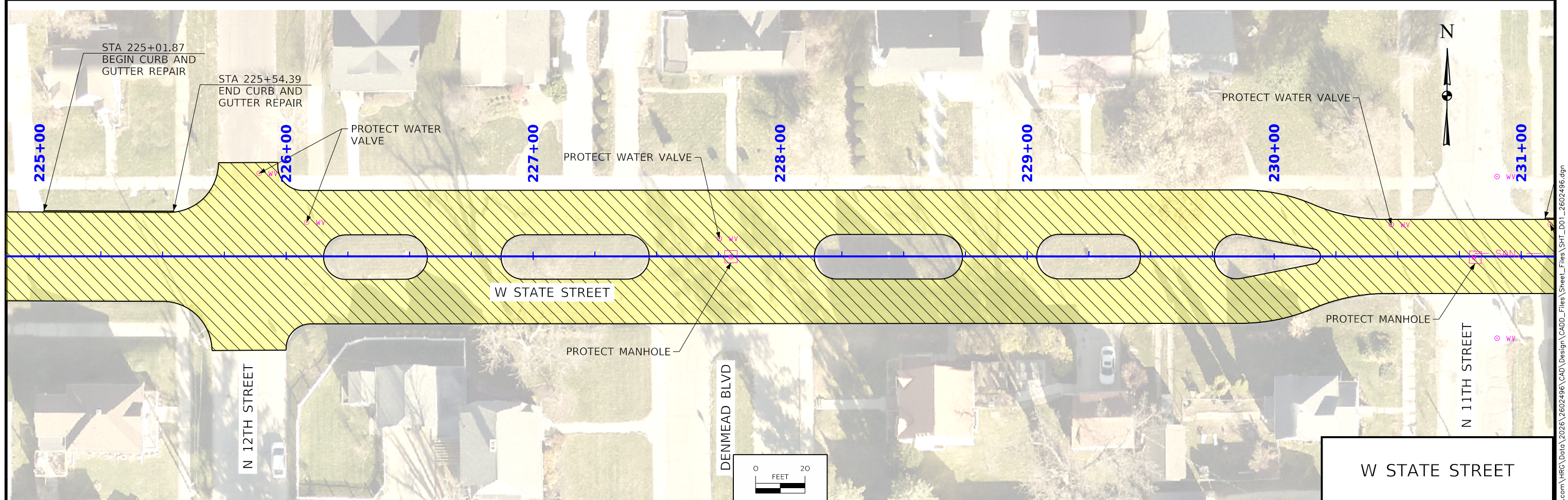
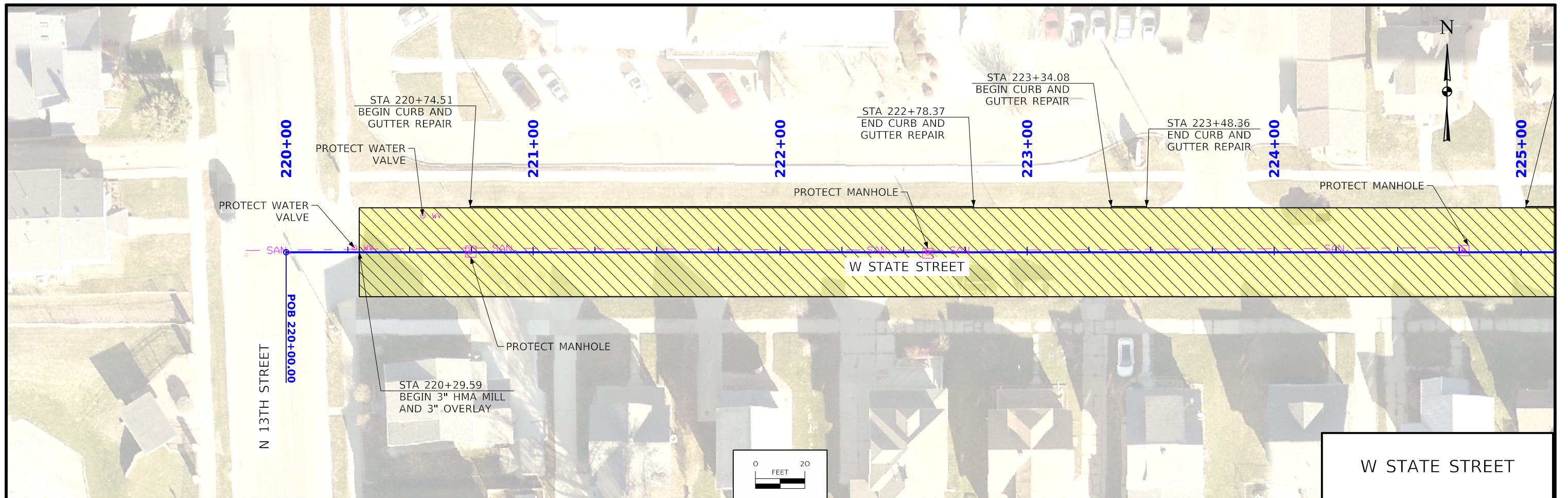

DRAWN BY: RJY JOB DATE: May 4, 2026 CAD DATE: 5/1/2026 2:14:45 PM
 APPROVED: CJ JOB NUMBER: 2602496 rtyrrel

NO.	DATE	BY	REVISION DESCRIPTION



2026 Street Rehabilitation
 City of Marshalltown

Plan & Profile Sheets

SHEET NO.
D.12

\\hrgreen.com\HRG\Data\2026\2602496\CAD\Design\CADD_Sheet_LFiles\Sheet_LFiles\GHT_D01_2602496.dgn



DRAWN BY: RJY	JOB DATE: May 4, 2026	CAD DATE: 5/1/2026	2:14:47 PM	NO.	DATE	BY	REVISION DESCRIPTION
APPROVED: CJ	JOB NUMBER: 2602496	rtyrrel					



2026 Street Rehabilitation
City of Marshalltown

Plan & Profile Sheets

SHEET NO.
D.13

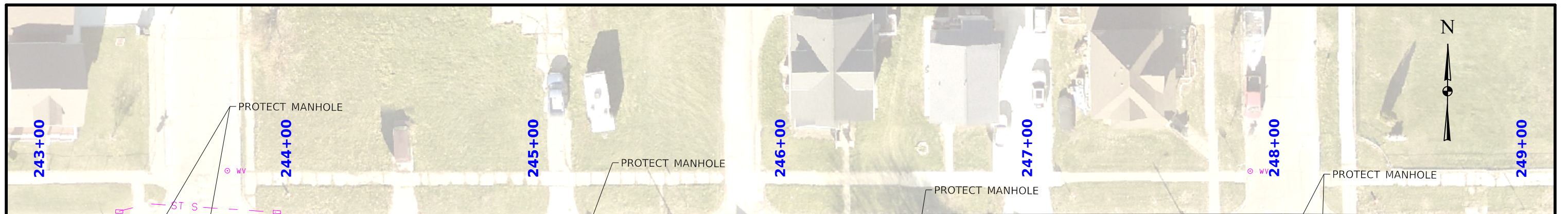

DRAWN BY: RJY JOB DATE: May 4, 2026 CAD DATE: 5/1/2026 2:14:48 PM
 APPROVED: CJ JOB NUMBER: 2602496 rtyrrel

NO.	DATE	BY	REVISION DESCRIPTION



2026 Street Rehabilitation
 City of Marshalltown

Plan & Profile Sheets

SHEET NO.
D.14

\\hrgreen.com\HRG\Data\2026\2602496\CAD\Design\CADD_Sheet_LFiles\Sheet_LFiles\SH_T_D01_2602496.dgn

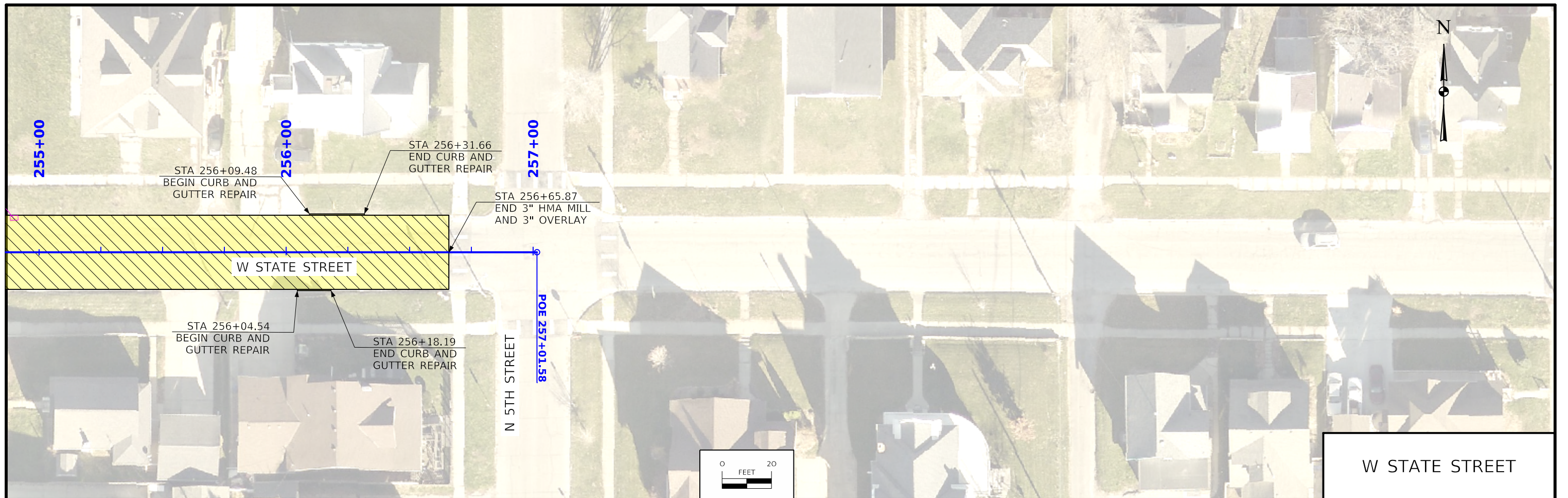

W STATE STREET

DRAWN BY: RJY JOB DATE: May 4, 2026 CAD DATE: 5/1/2026 2:14:49 PM
 APPROVED: CJ JOB NUMBER: 2602496 rtyrrel

NO.	DATE	BY	REVISION DESCRIPTION



2026 Street Rehabilitation
 City of Marshalltown

Plan & Profile Sheets

SHEET NO.
D.15

\\hrgreen.com\HRG\Data\2026\2602496\CAD\Design\CADD_Files\Sheet_L_Files\Sheet_L_Files\GHT_D01_2602496.dgn

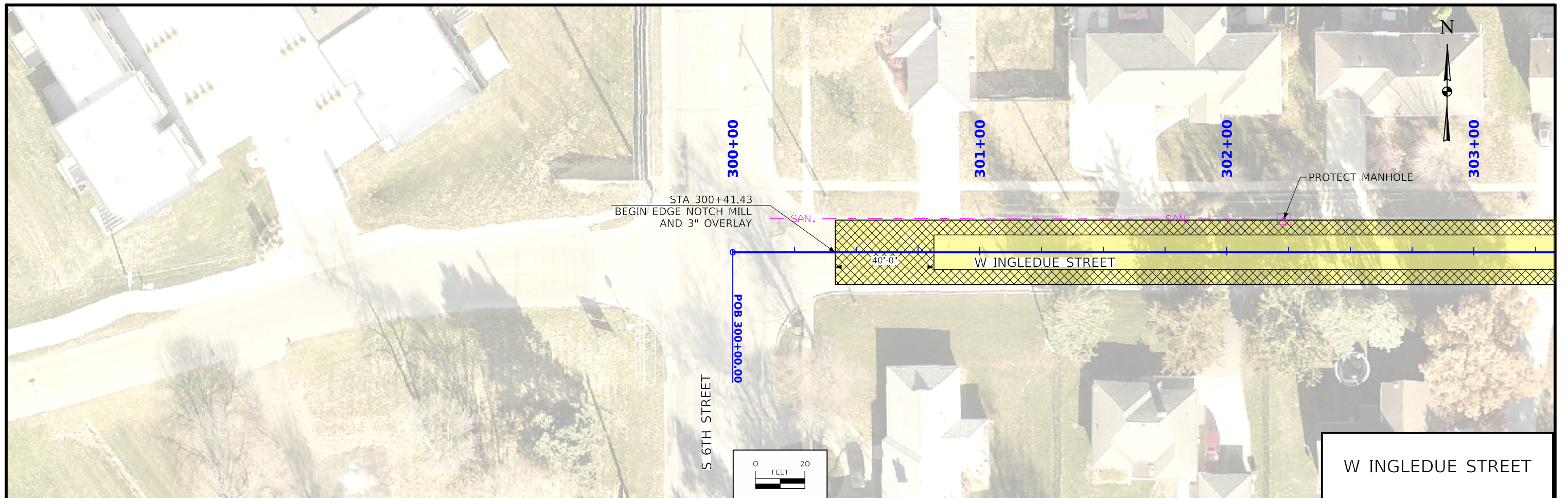

DRAWN BY: RJY JOB DATE: May 4, 2026 CAD DATE: 5/1/2026 2:14:50 PM
 APPROVED: CJ JOB NUMBER: 2602496 rtyrrel

NO.	DATE	BY	REVISION DESCRIPTION



2026 Street Rehabilitation
 City of Marshalltown

Plan & Profile Sheets

SHEET NO.
D.16

\\hrgreen.com\HRG\Data\2026\2602496\CAD\Design\CADD_Sheet_LFiles\Sheet_LFiles\GHT_D01_2602496.dgn

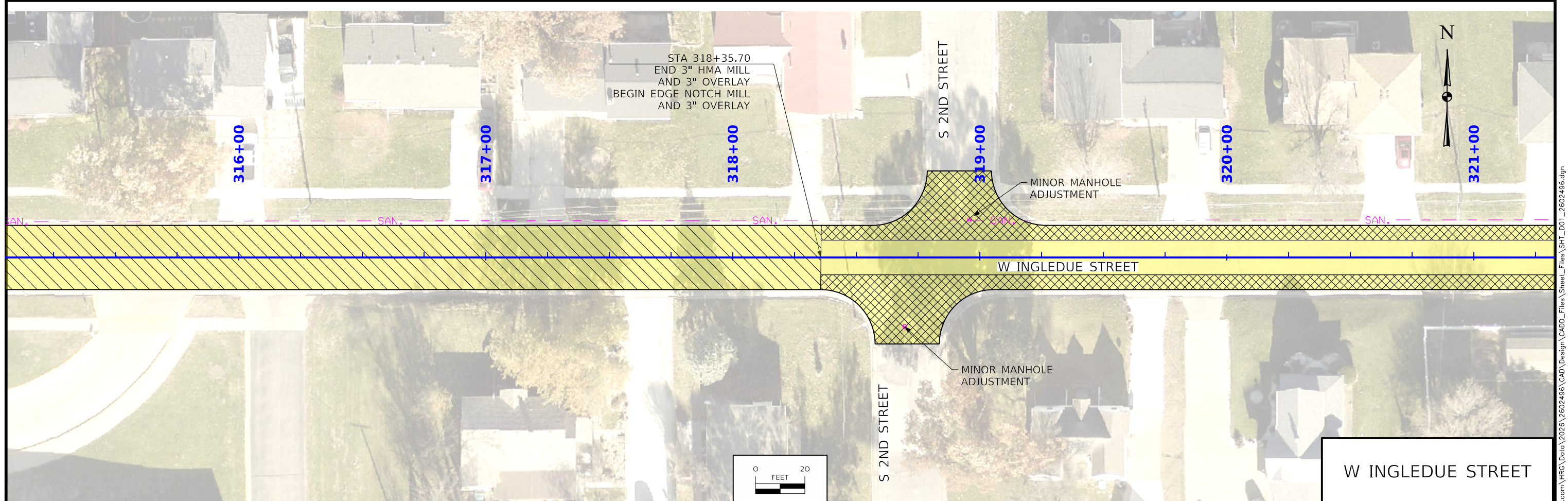
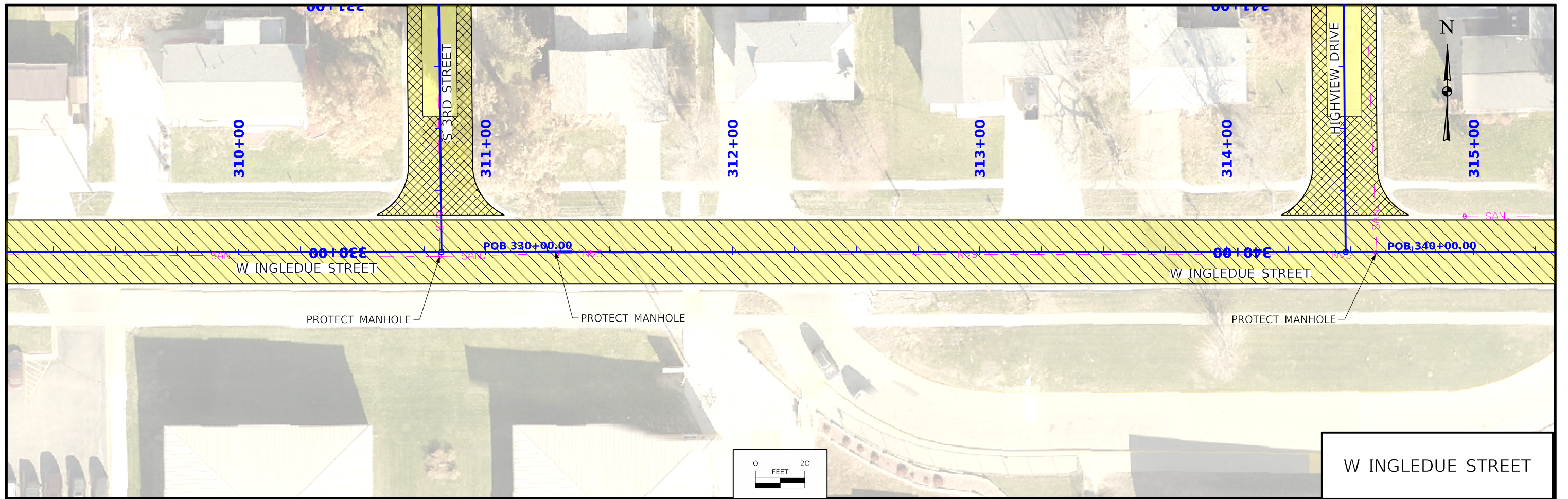

DRAWN BY: RJY JOB DATE: May 4, 2026 CAD DATE: 5/1/2026 2:14:53 PM
 APPROVED: CJ JOB NUMBER: 2602496 rtyrrel

NO.	DATE	BY	REVISION DESCRIPTION



2026 Street Rehabilitation
 City of Marshalltown

Plan & Profile Sheets

SHEET NO.
D.17

\\hrgreen.com\HRG\Data\2026\2602496\CAD\Design\CADD_Files\Sheet_LFiles\Sheet_LFiles\GHT_D01_2602496.dgn

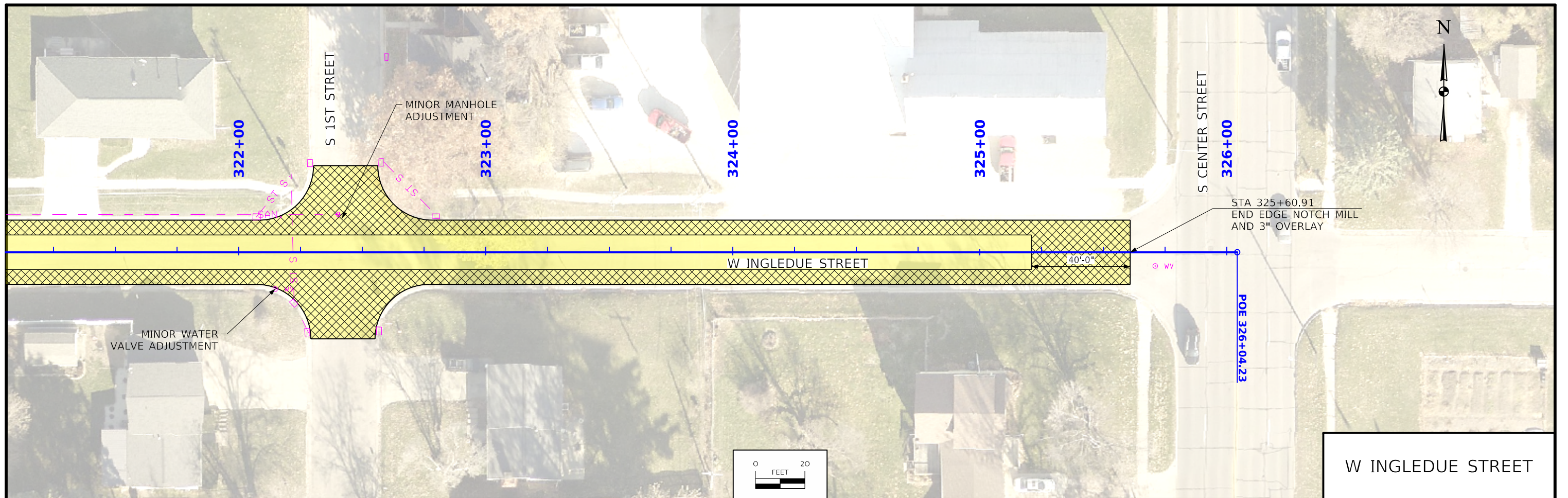

DRAWN BY: RJY JOB DATE: May 4, 2026 CAD DATE: 5/1/2026 2:14:54 PM
 APPROVED: CJ JOB NUMBER: 2602496 rtyrrel

NO.	DATE	BY	REVISION DESCRIPTION



2026 Street Rehabilitation
City of Marshalltown

Plan & Profile Sheets

SHEET NO.
D.18

\\hrgreen.com\HRG\Data\2026\2602496\CAD\Design\CADD_Files\Sheet_Sheet_L_Files\GHT_D01_2602496.dgn

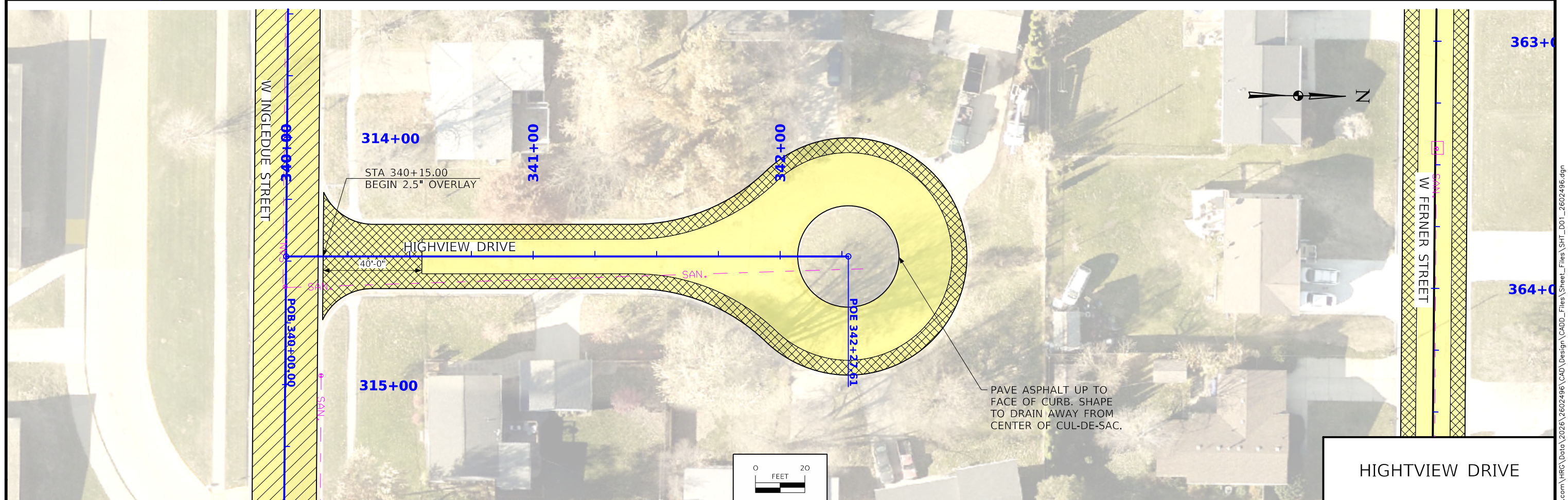
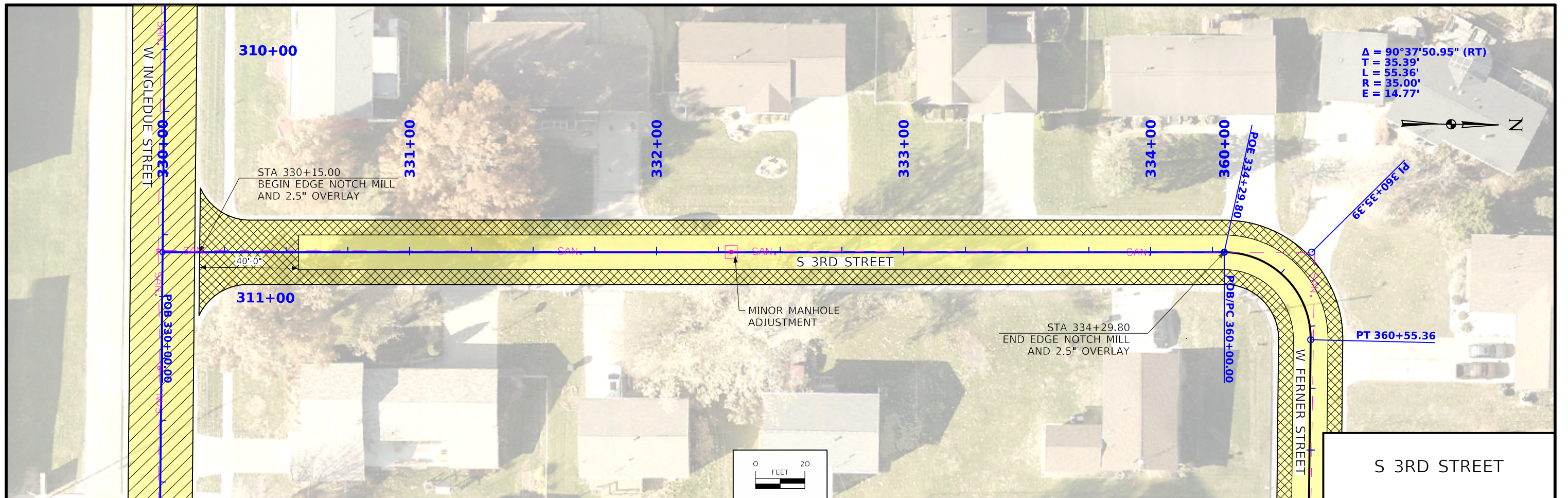

\\hrgreen.com\HRG\Data\2026\2602496\CAD\Design\CADD_Sheet_L_Files\Sheet_L_Files\GHT_D01_2602496.dgn

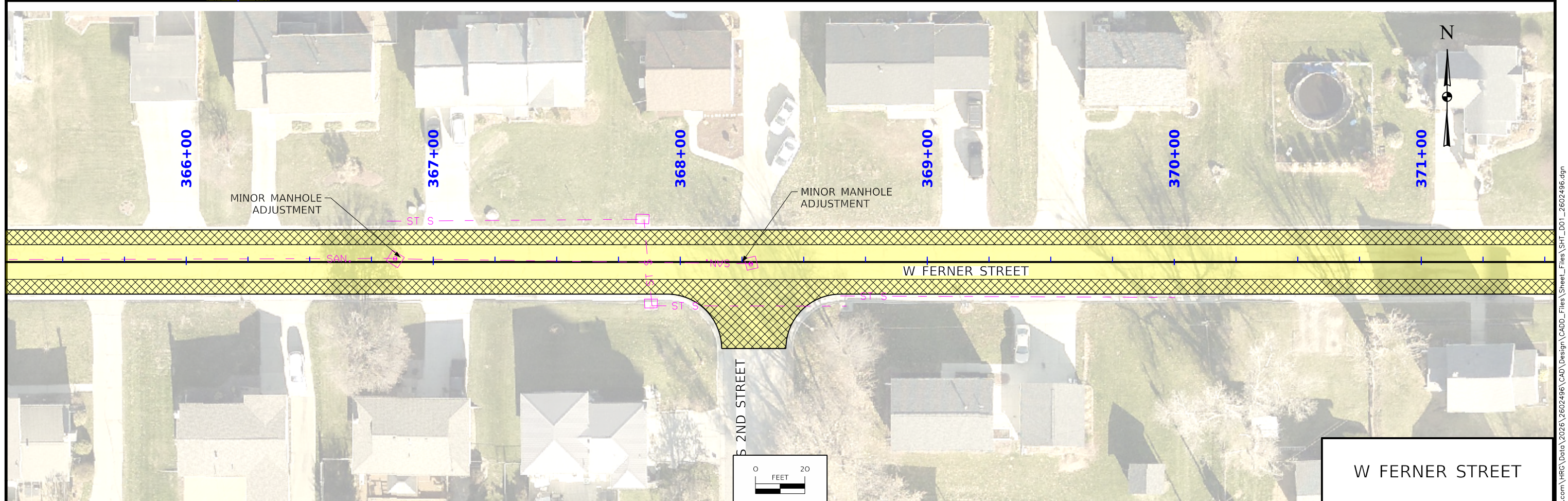
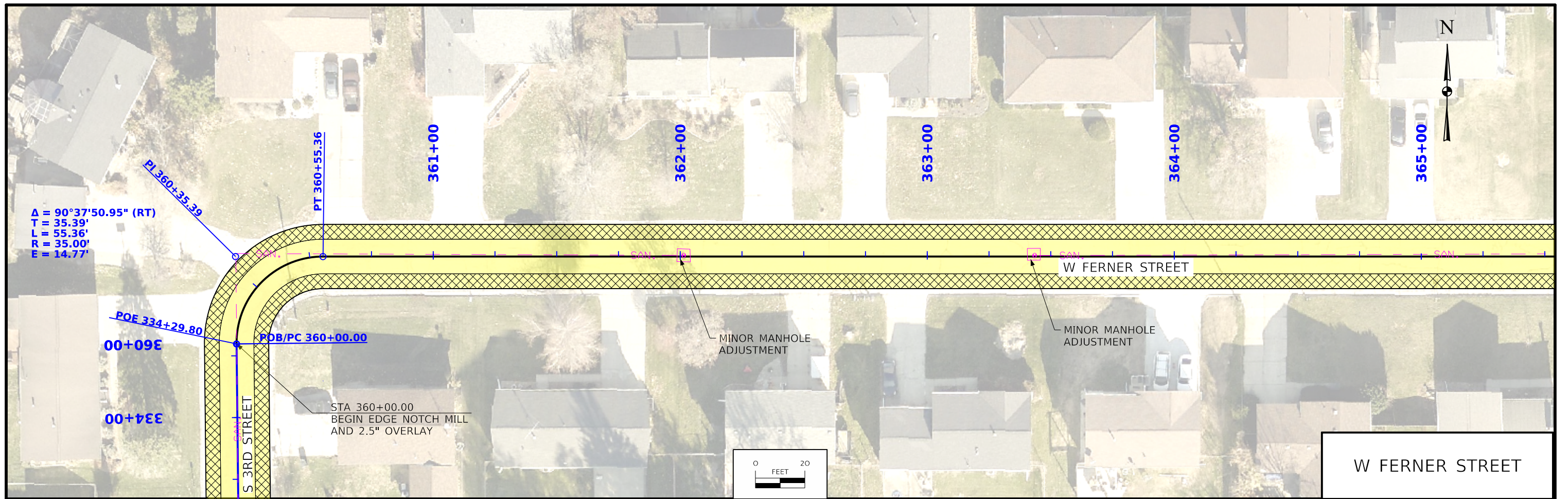

DRAWN BY: RJY JOB DATE: May 4, 2026 CAD DATE: 5/1/2026 2:14:57 PM
 APPROVED: CJ JOB NUMBER: 2602496 rtyrrel

NO.	DATE	BY	REVISION DESCRIPTION



2026 Street Rehabilitation
 City of Marshalltown

Plan & Profile Sheets

SHEET NO.
D.20

\\hrgreen.com\HRG\Data\2026\2602496\CAD\Design\CADD_Sheet_Lines_Sheet_Lines_SHT_D01_2602496.dgn

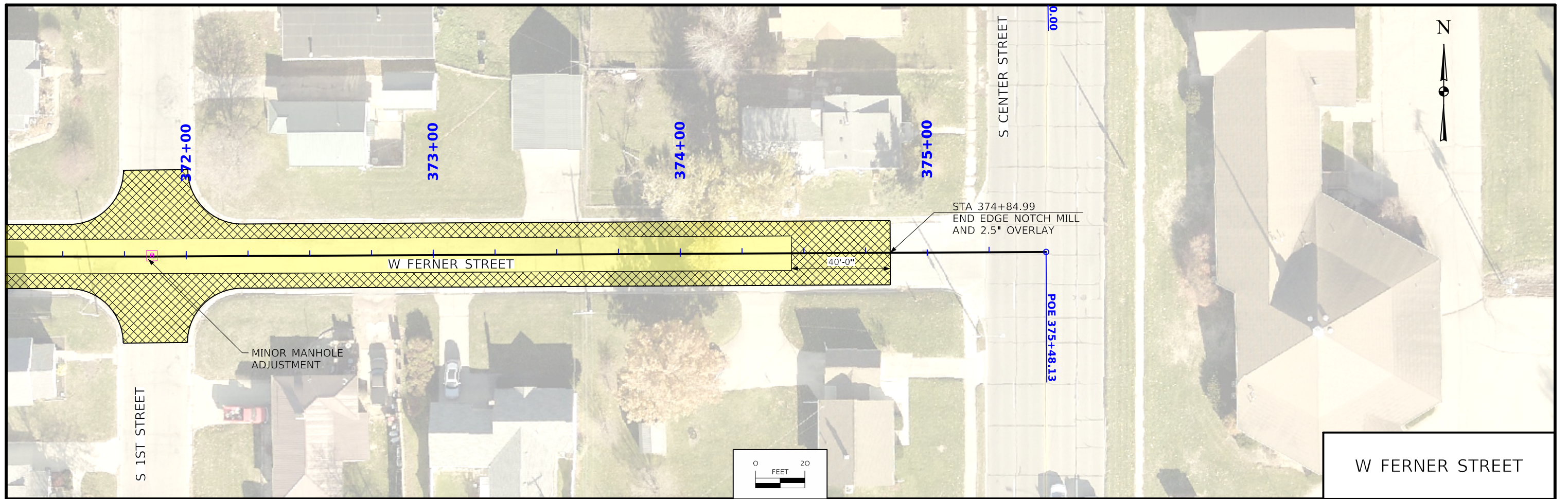

DRAWN BY: RJJ JOB DATE: May 4, 2026 CAD DATE: 5/1/2026 2:14:58 PM
 APPROVED: CJ JOB NUMBER: 2602496 rtyrrel

NO.	DATE	BY	REVISION DESCRIPTION



2026 Street Rehabilitation
 City of Marshalltown

Plan & Profile Sheets

SHEET NO.
D.21

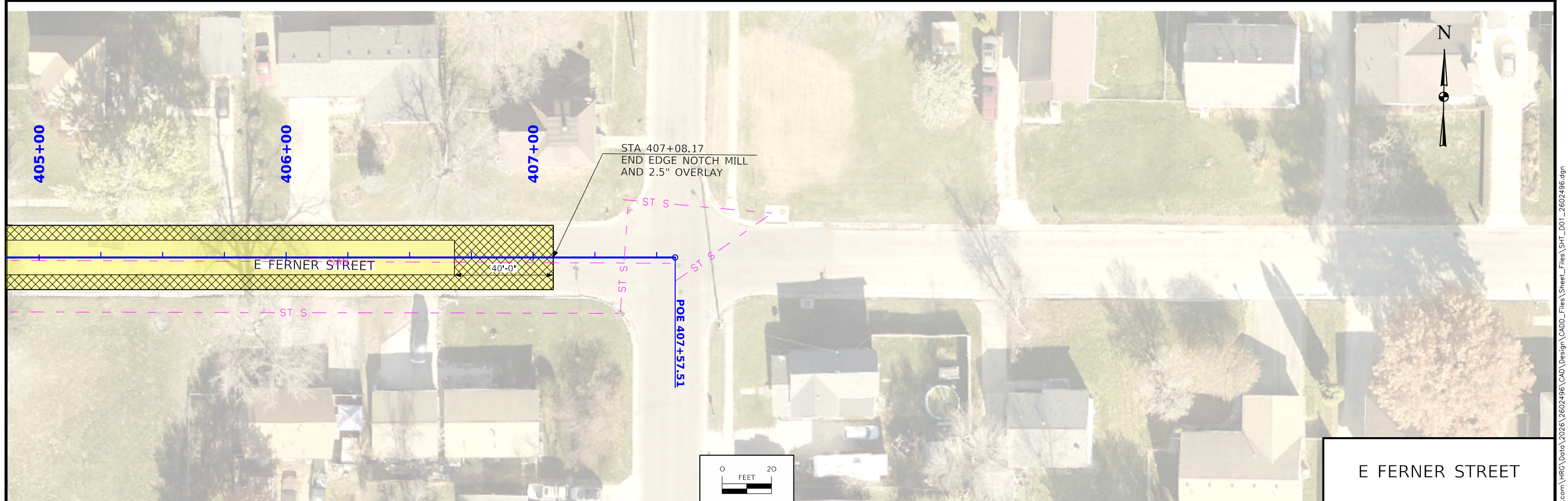
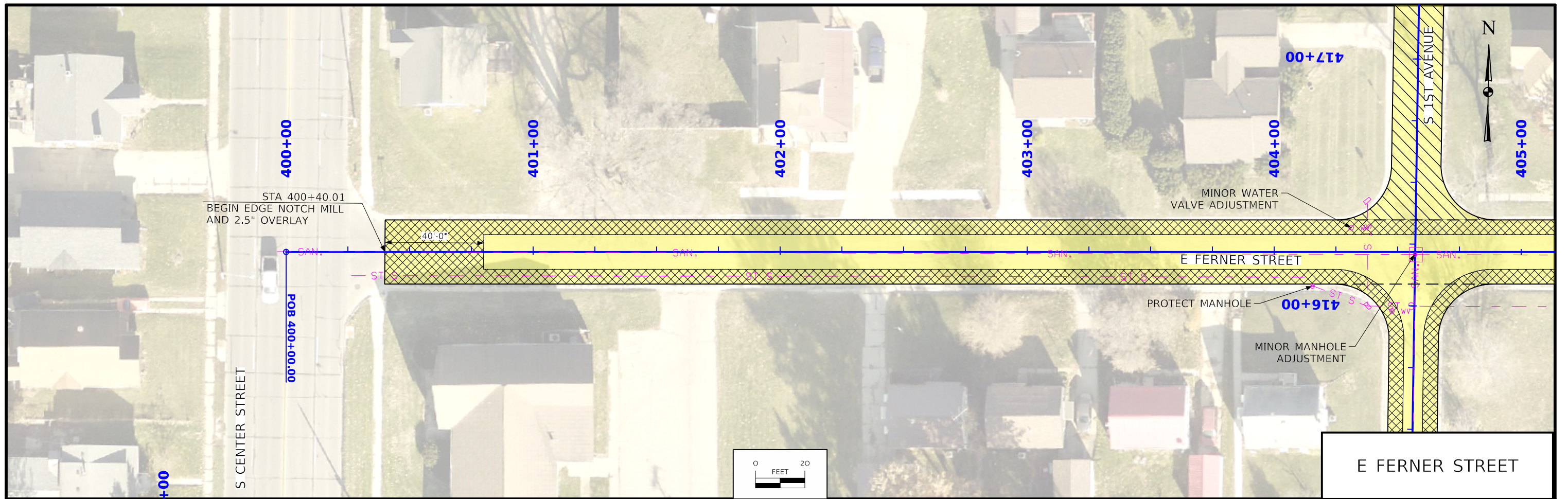

DRAWN BY: RJY APPROVED: CJ	JOB DATE: May 4, 2026 JOB NUMBER: 2602496	CAD DATE: 5/1/2026 2:14:59 PM rtyrrel	<table border="1"> <thead> <tr> <th>NO.</th> <th>DATE</th> <th>BY</th> <th>REVISION DESCRIPTION</th> </tr> </thead> <tbody> <tr> <td> </td> <td> </td> <td> </td> <td> </td> </tr> </tbody> </table>	NO.	DATE	BY	REVISION DESCRIPTION						2026 Street Rehabilitation City of Marshalltown	Plan & Profile Sheets	SHEET NO. D.22
NO.	DATE	BY	REVISION DESCRIPTION												

\\hrgreen.com\HRG\Data\2026\2602496\CAD\Design\CADD_Files\Sheet_Sheet_L_Files\Sheet_SHT_D01_2602496.dgn

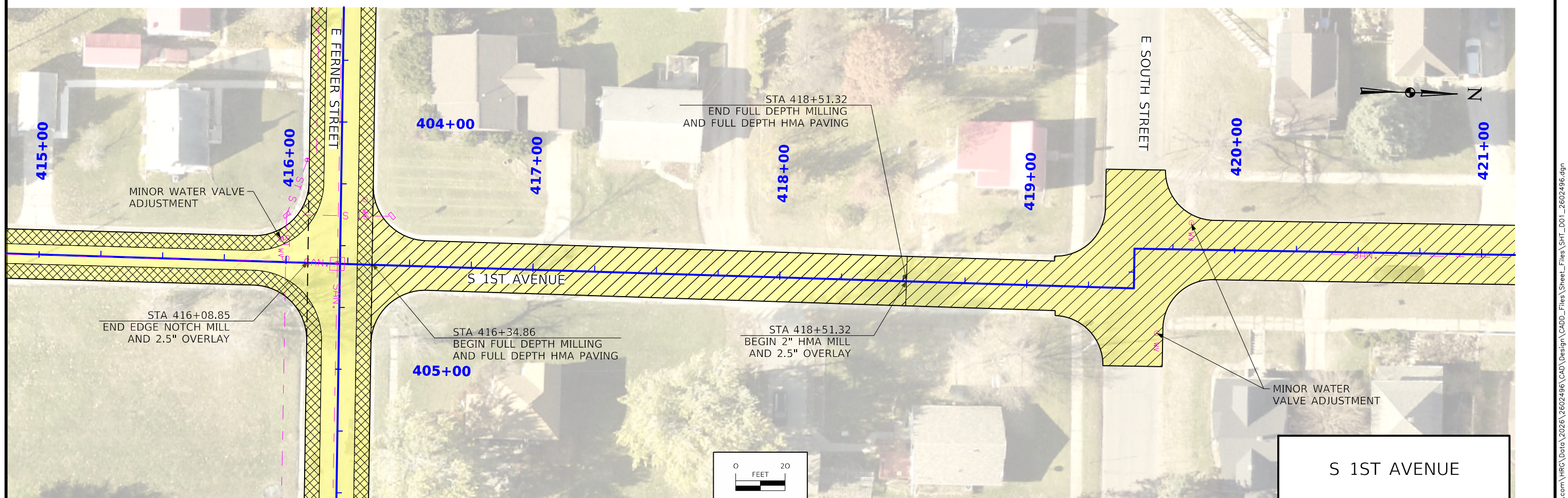
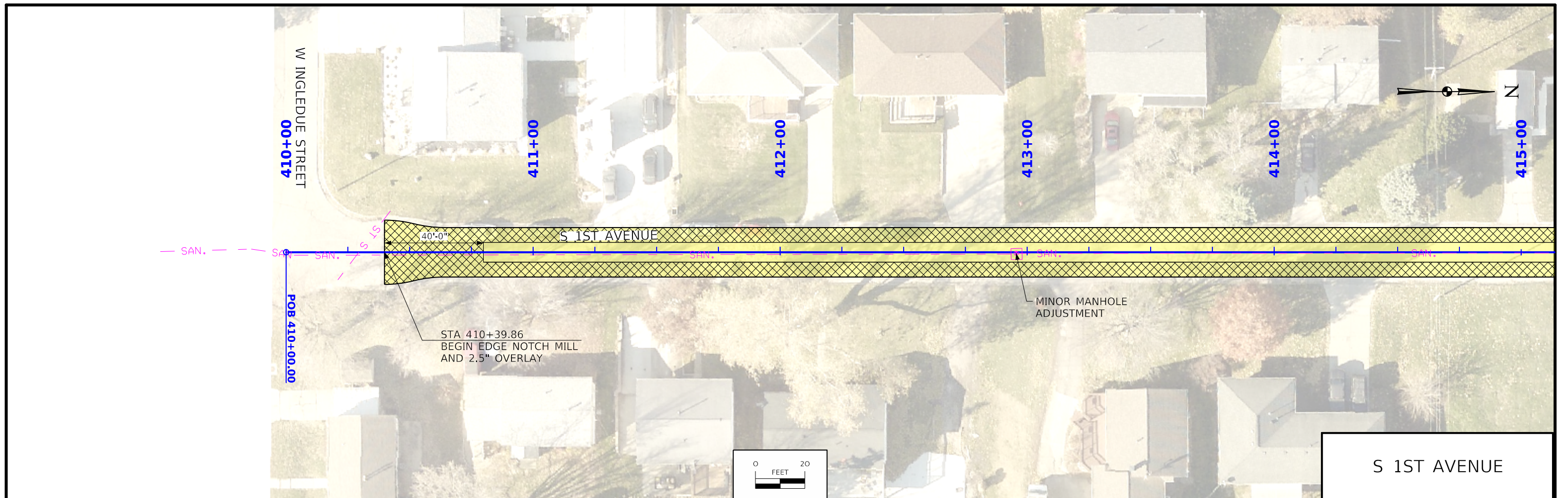

DRAWN BY: RJY JOB DATE: May 4, 2026 CAD DATE: 5/1/2026 2:15:02 PM
 APPROVED: CJ JOB NUMBER: 2602496 rtyrrel

NO.	DATE	BY	REVISION DESCRIPTION



2026 Street Rehabilitation
 City of Marshalltown

Plan & Profile Sheets

SHEET NO.
D.23

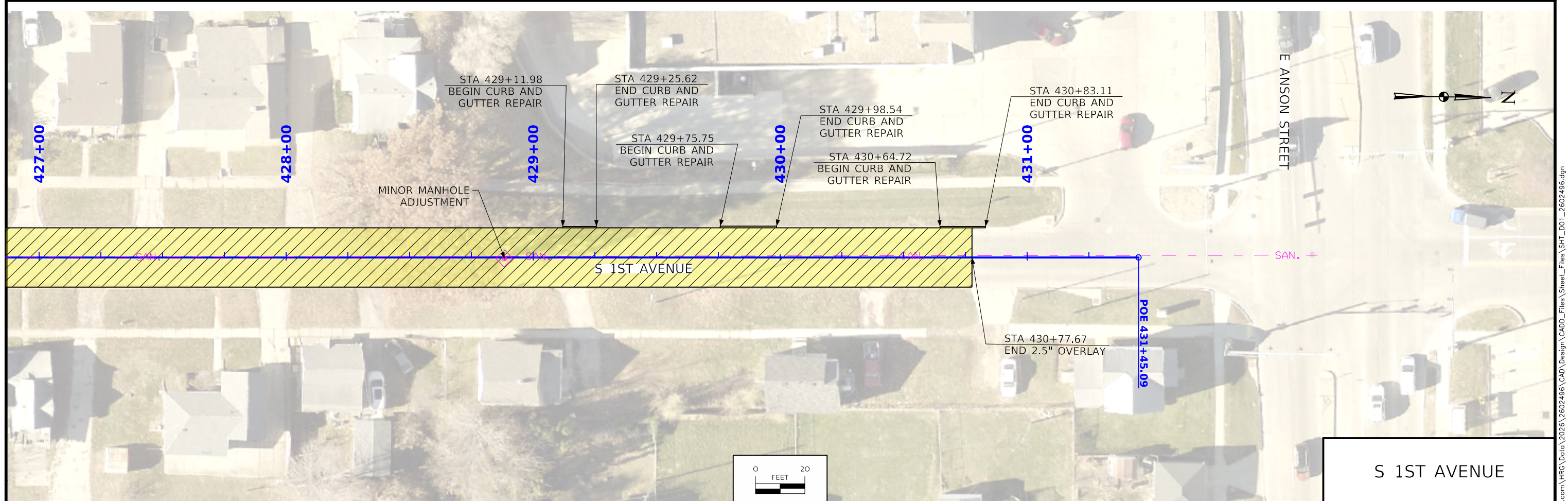
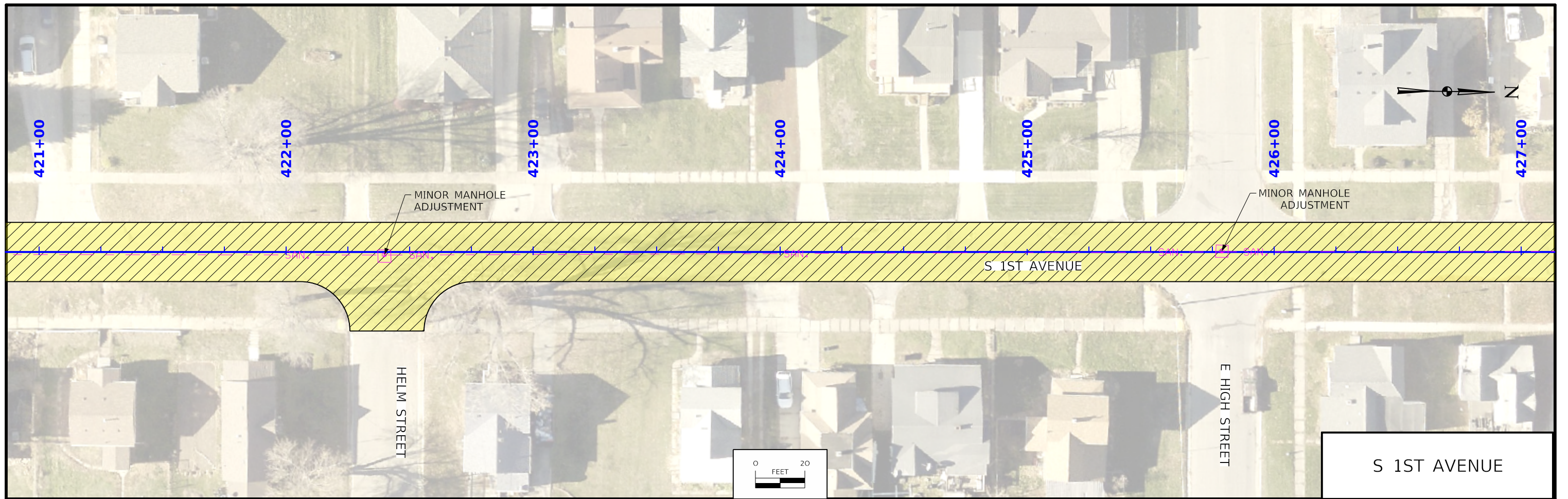

DRAWN BY: RJY JOB DATE: May 4, 2026 CAD DATE: 5/1/2026 2:15:03 PM
 APPROVED: CJ JOB NUMBER: 2602496 rtyrrel

NO.	DATE	BY	REVISION DESCRIPTION



2026 Street Rehabilitation
 City of Marshalltown

Plan & Profile Sheets

SHEET NO.
D.24

\\hrgreen.com\hrg\Data\2026\2602496\CAD\Design\CADD_Sheet_Lines_Sheet_Lines_SHT_D01_2602496.dgn

OPINION OF PROBABLE PROJECT COST
2026 Marshalltown Street Rehabilitation Project
2602496
City of Marshalltown
5/4/2026
Prepared by HR Green



#	CODE	ITEM	UNIT	UNIT PRICE	QUANTITIES	COST
					TOTAL	TOTAL
BASE BID						
1	2010-D-3	TOPSOIL, OFF-SITE	CY	\$ 80.00	94	\$ 7,520.00
2	2010-I	SUBGRADE TREATMENT, GEOGRID, TYPE 4	SY	\$ 8.00	433	\$ 3,464.00
3	5020-F	VALVE BOX ADJUSTMENT, MINOR	EA	\$ 100.00	9	\$ 900.00
4	6010-E-1	MANHOLE ADJUSTMENT, MINOR	EA	\$ 500.00	29	\$ 14,500.00
5	7010-E	CURB AND GUTTER, 2.5 FT	LF	\$ 75.00	1229	\$ 92,175.00
6	7010-F	BEAM CURB	LF	\$ 75.00	239	\$ 17,925.00
7	7020-A	PAVEMENT, ASPHALT, STANDARD TRAFFIC, BASE, 3/4", PG 58-28S	TON	\$ 125.00	78	\$ 9,750.00
8	7020-A	PAVEMENT, ASPHALT, STANDARD TRAFFIC, INTERMEDIATE, 1/2", PG 58-28S	TON	\$ 125.00	39	\$ 4,875.00
9	7020-I	ASPHALT PAVEMENT SAMPLES AND TESTING	LS	\$ 1,500.00	1	\$ 1,500.00
10	7021-A	ASPHALT OVERLAY, INTERLAYER BASE, 3/8", PG 58-34E	TON	\$ 160.00	3611	\$ 577,760.00
11	7021-A	ASPHALT OVERLAY, SURFACE, 1/2", PG 58-28S, STANDARD TRAFFIC	TON	\$ 125.00	6319	\$ 789,875.00
12	7040-B	SUBBASE OVER-EXCAVATION	TON	\$ 45.00	124	\$ 5,580.00
13	7040-G	MILLING	SY	\$ 5.00	48138	\$ 240,690.00
14	7040-I	CURB AND GUTTER REMOVAL	LF	\$ 15.00	1468	\$ 22,020.00
15	7999-A	CLEANING AND PREPARATION OF BASE	MILE	\$ 5,000.00	3.29	\$ 16,450.00
16	7999-B	PARTIAL DEPTH PATCHES, HMA	TON	\$ 400.00	430	\$ 172,000.00
17	8030-A	TEMPORARY TRAFFIC CONTROL	LS	\$ 99,000.00	1	\$ 99,000.00
18	9010-A	CONVENTIONAL SEEDING, FERTILIZING, AND MULCHING, TYPE 1	AC	\$ 10,000.00	0.2	\$ 2,000.00
19	11020-A	MOBILIZATION	LS	\$ 208,000.00	1	\$ 208,000.00
ADD ALTERNATES						
20	5020-F	VALVE BOX ADJUSTMENT, MINOR	EA	\$ 100.00	1	\$ 100.00
21	6010-E-1	MANHOLE ADJUSTMENT, MINOR	EA	\$ 500.00	5	\$ 2,500.00
22	7010-E	CURB AND GUTTER, 2.5 FT	LF	\$ 75.00	112	\$ 8,400.00
23	7021-A	ASPHALT OVERLAY, INTERLAYER BASE, 3/8", PG 58-34E	TON	\$ 160.00	238	\$ 38,080.00
24	7021-A	ASPHALT OVERLAY, SURFACE, 1/2", PG 58-28S, STANDARD TRAFFIC	TON	\$ 125.00	362	\$ 45,250.00
25	7040-G	MILLING	SY	\$ 5.00	2136	\$ 10,680.00
26	7040-I	CURB AND GUTTER REMOVAL	LF	\$ 15.00	112	\$ 1,680.00
27	7999-A	CLEANING AND PREPARATION OF BASE	MILE	\$ 5,000.00	0.27	\$ 1,350.00
28	7999-B	PARTIAL DEPTH PATCHES, HMA	TON	\$ 400.00	35	\$ 14,000.00
BASE BID CONSTRUCTION COST SUBTOTAL						\$ 2,285,984.00
ADD ALTERNATES CONSTRUCTION COST SUBTOTAL						\$ 122,040.00
TOTAL CONSTRUCTION PROJECT COST						\$ 2,408,024.00



**MARSHALLTOWN
MORE THAN EVER**

**Mike Ladehoff, Mayor
Carol Webb, City Administrator
24 North Center Street
Marshalltown, IA 50158
PH 641.754.5701 • FX 641.754.5717**

To: Mayor and City Council
From: Kelsie Stafford, Director
Meeting Date: May 11, 2026
Re: Resolution Approving Contract Change Order #6 for the Water Plaza at Mega-10 Park Project #PRK22004, a Decrease of \$12,826.00

Strategic Plan Objective:

- Goal 2: Enhance Marshalltown's public image.
- Goal 3: Continually improve and sustain the City's infrastructure, organization, and services.
- Goal 4: Partner with citizens, for-profit, non-profit and others to improve quality of life.

Recommended:

Staff recommends approval of Change Order #6, a decrease of \$12,826.00, for the Water Plaza at Mega-10 Park Project #PRK22004 as submitted.

Budget Impact:

Due to an adverse effect of the curing blanket on the wet deck concrete appearance, Edge Commercial will reimburse the City of Marshalltown for the cost of additional non-skid rubberized coating to cover the entirety of the wet deck. An additional 500 sq. ft. of coating is required at an agreed reimbursement price of \$22 per sq. ft. The current project expenses and funding sources are below:

Project Expenses:

Design Engineering	\$296,400.00	Bolton & Menk
Construction Engineering	\$190,185.00	Bolton & Menk
Allowance – Rubberized Coating	\$55,000.00	TBD
Allowance – Landscaping	\$7,500.00	City of Marshalltown - Parks
Allowance - Signage	\$50,000.00	Coordination w/ ACA
Allowance – Sculpture	\$395,000.00	Coordination w/ ACA
Estimated Permits, Util, Etc	\$5,710.00	City + Others

Land Survey for YMCA Agreement	\$4,095.00	Clapsaddle-Garber Associates
Electrical Service & Transformer	\$30,723.50	Alliant Energy
Electrical Service Installation	\$2,545.09	Alliant Energy
Construction Bid (+ CO-0)	\$1,887,325.00	Edge Commercial
Construction Change Order 1	(\$2,703.00)	Edge Commercial
Construction Change Order 2	\$945.00	Edge Commercial
Construction Change Order 3	\$9,144.00	Edge Commercial
Construction Change Order 4	\$2,926.93	Edge Commercial
Construction Change Order 5	(\$340.00)	Edge Commercial
Construction Engineering Amendment 4	\$40,000.00	Bolton & Menk
Construction Change Order 6	(\$12,826.00)	Edge Commercial
TOTAL	\$2,943,159.02	

Project Funding:

City of Marshalltown Bond Fund 364	\$500,000.00	
City of Marshalltown ARPA Fund 389	\$68,063.65	
Destination Iowa Grant	\$578,015.00	
Wellmark Grant	\$100,000.00	
Donations	\$125,000.00	City Fund 364
Donations	\$1,071,059.50	City Fund 140
Donations	\$445,000.00	ACA Held
City of Marshalltown Bond Fund 364	\$190,000.00	Contingency from Riverview Park
Electrical Reimbursement	\$30,000.00	Bolton & Menk / KED Bluestone
TOTAL	\$3,107,138.15	

Description/Background:

The curing blanket process used during the wet deck concrete pour created an adverse "tiger-striping" cosmetic effect on the concrete surface. The original non-skid rubberized coating plan included some areas of the wet deck that were not covered by the non-slip coating. Because this tiger-striping has caused a cosmetic appearance that was not intended, Bolton & Menk, Edge Commercial and City staff agreed that covering the entirety of the wet deck in the non-slip coating would prove to be an acceptable solution to resolve the issue.

City staff worked to create an updated non-skid rubberized coating plan that would cover all areas of the wet deck, resulting in an additional 500 sq. ft. of coverage. This exhibit was included in the bid packet for this supplemental project set to begin in mid-May. Edge Commercial is reimbursing the City of Marshalltown for the additional cost incurred, in the amount of \$12,826.00. City staff recommend City Council approval of Change Order 6 as submitted.

Attachments:

1. 2026-05-11_2026-091_Resolution Approving CO6 Water Plaza at Mega-10 Park
2. PRK22004 - Water Plaza - Change Order 06_BMI_Edge_Signed

RESOLUTION APPROVING CONTRACT CHANGE ORDER #6 FOR WATER PLAZA AT MEGA-10 PARK PROJECT, PROJECT #22004, A DECREASE OF \$12,826.00.

WHEREAS, the City of Marshalltown, Iowa, has heretofore entered into a contract with Edge Commercial for the Water Plaza at Mega-10 Park Project #PRK22004; and

WHEREAS, a change that results in a decrease is requested for items to complete the project.

NOW, THEREFORE, BE IT RESOLVED BY THE COUNCIL OF THE CITY OF MARSHALLTOWN, IOWA:

Section 1. That the contract Change Order #6 for the Water Plaza at Mega-10 Park Project #22004, in the decreased amount of \$12,826.00 is hereby accepted and approved.

Passed this 11th day of May 2026, and signed this _____ day of May 2026.

CITY OF MARSHALLTOWN, IOWA

Mike Ladehoff, Mayor

ATTEST:

Alicia Hunter, CMC, City Clerk



Bolton & Menk
 Change Order Details
 Marshalltown - Water Plaza

Description	Marshalltown Interactive Water Feature
Prime Contractor	Edge Commercial 3155 SE Miehe Dr, Ste 2 Grimes, IA 50111
Change Order	6
Status	Pending
Date Created	04/25/2026
Type	Local Funding
Summary	Change Order 6: Tiger Striping Adjustment
Change Order Description	Due to the tiger striping on the concrete, Edge & the City came to an agreement that Edge will reimburse the City for additional tuffcoat to cover the original 3,290 SF affected by tiger striping plus any additional tuffcoat needed to cover concrete concrete repairs at a rate of \$22/SF.
Awarded Project Amount	\$1,887,325.00
Authorized Project Amount	\$1,897,297.93
Change Order Amount	-\$12,826.00
Revised Project Amount	\$1,884,471.93

New Items

Line Number	Item ID	Unit	Quantity	Unit Price	Extension
Section: 1 - Description					

Line Number	Item ID	Unit	Quantity	Unit Price	Extension
010	0000-999-N	SF	583.000	-\$22.000	-\$12,826.00

SQUARE FEET ITEM: Tuffcoat (Non-Rubberized Skid Coating, Adjusted Price)

Reason: Reimbursement to cover tiger-striped concrete with Tuff-Coat

item Total: -\$12,826.00

Signatures

Approved -  Date: 5/4/20
Contractor

Recommended -  Date: 05/04/2026
Project Engineer

Approved - _____ Date: _____
City



**MARSHALLTOWN
MORE THAN EVER**

**Mike Ladehoff, Mayor
Carol Webb, City Administrator
24 North Center Street
Marshalltown, IA 50158
PH 641.754.5701 • FX 641.754.5717**

To: Mayor and City Council
From: Kelsie Stafford, Director
Meeting Date: May 11, 2026
Re: Resolution Setting a Public Hearing on the Status of Funding Activities for the Community Development Block Grant - Disaster Recovery Tree Planting Project, #PRK24002

Strategic Plan Objective:

Goal 2: Enhance Marshalltown's public image.

Goal 3: Continually improve and sustain the City's infrastructure, organization, and services.

Goal 4: Partner with citizens, for-profit, non-profit, and others to improve quality of life.

Recommended:

Staff recommends proceeding with a public hearing set for May 26, 2026 on the status of funding activities for the Community Development Block Grant - Disaster Recovery Tree Planting Project, #PRK24002.

Budget Impact:

The City of Marshalltown was awarded \$200,000.00 through the Iowa Economic Development Authority and the Community Development Block Grant - Disaster Recovery Program to plant trees in designated areas of the First Ward. A public hearing on the status of funding activities is a requirement of acceptance of these grant monies.

Description/Background:

Staff have successfully executed the CDBG-DR Tree Planting Project #PRK24002 to plant 341 trees in approved areas throughout the First Ward. The original project scope included the planting of 200 trees, however, the lowest responsible bid allowed for remaining grant funds to be spent in the purchase of an additional 141 trees to be planted. Minor punch list items remain as well as final invoicing prior to project acceptance being presented for City Council's consideration in the near future.

Upon Council approval, a public hearing on the status of funding activities for the project will be set for 5:30 p.m. on Tuesday, May 26, 2026 in the City Council Chambers at 10 W. State Street in Marshalltown.

Attachments:

1. 2026-05-11_2026-092_Resolution Setting Public Hearing PRK24002 CDBG SOFA
2. Marshalltown - NOTICE OF PUBLIC HEARING publication CDBG Tree Planting Project PRK24002

**RESOLUTION SETTING PUBLIC HEARING ON STATUS OF FUNDING
ACTIVITIES FOR COMMUNITY DEVELOPMENT BLOCK GRANT – DISASTER
RECOVERY TREE PLANTING PROJECT, #PRK24002.**

WHEREAS, the City of Marshalltown, Iowa, was awarded funding for tree planting through the Community Development Block Grant – Disaster Recovery Program; and

WHEREAS, a public hearing on the status of funds and activities is a requirement of acceptance of granted monies through the Community Development Block Grant – Disaster Recovery Program; and

WHEREAS, the City of Marshalltown, Iowa, City Council desires to set a public hearing for the public.

NOW, THEREFORE, BE IT RESOLVED BY THE COUNCIL OF THE CITY OF MARSHALLTOWN, IOWA:

Section 1. That a public hearing on the status of funding activities for the Community Development Block Grant – Disaster Recovery Tree Planting Project, #PRK24002 shall be set on May 26, 2026 at 5:30 p.m.

Passed this 11th day of May 2026, and signed this _____ day of May 2026.

CITY OF MARSHALLTOWN, IOWA

Mike Ladehoff, Mayor

ATTEST:

Alicia Hunter, CMC, City Clerk

NOTICE OF PUBLIC HEARING

Notice is hereby given that the City of Marshalltown will hold a public hearing on the status of the Community Development Block Grant – Disaster Recovery (CDBG-DR) for tree planting. The hearing will take place at 5:30 p.m. on May 26, 2026 at the City of Marshalltown Council Chambers, 10 West State Street, Marshalltown, IA 50158. At the hearing, the following information will be covered: a general description of accomplishments to date, a summary of funding of the proposed activity and source of funds, a summary of the total of funds spent thus far by source, a general description of remaining work to be done, the location of the proposed activity and a general description of changes made to the project budget, performance targets, activity schedules, project scope, location, objectives or beneficiaries. If you have any questions concerning the project or if you require special accommodations to attend the hearing such as handicapped accessibility or translation services, please contact Alicia Hunter, City of Marshalltown City Clerk, at 641-754-5701. Persons interested in the status of funding or the progress of the project are welcome to attend this meeting.

Alicia Hunter
Marshalltown City Clerk

SPECIAL CLASS "C" RETAIL ALCOHOL LICENSE APPLICATION

Business Information

Name of Legal Entity: TRIPLE K SIPS LLC

FEIN: XX-XXX3170

Business Type: Limited Liability Company

This business is registered with the Secretary of State.

Business Number of Secretary of State: 0857819

Premises Information

Premises DBA: LUCKY WIFE WINE SLUSHIES

Premises Address: 1308 E OLIVE ST MARSHALLTOWN IA 50158-8849

Premises Type: Special Event

Number of Floors: 1

Control of Premises: Lease

Is your premises equipped with at least one adequate, conveniently located indoor or outdoor toilet facility for use by patrons?

Yes

Does your premises conform to all local and state health, fire and building laws and regulations?

Yes

Is your establishment equipped with tables and seats to accommodate a minimum of 25?

Yes

License Information

Effective Date: 09-Jul-2026

Length of License Requested: 5DAY

Privilege(s) Requested

Outdoor Service - Allows the selling/serving of alcoholic beverages by the license/permit in a designated, adjacent outdoor area.

Provided description of the Outdoor Service Area:

Parking lot area

Endorsements

Local Authority: City of Marshalltown

Dramshop Company: FOUNDERS INSURANCE COMPANY

Ownership Information

Type	Name	ID Type	ID	DOB	Phone	Address	Percentage
Individual	KEMPER, AMELIA	SSN	***-**-9745	24-Oct-19 93	64175059 90	1869 295TH ST TOLEDO IA 52342-9502	33.33
Individual	PANSEGRAU , NIKKI	SSN	***-**-6106	31-May-1 984	64169110 60	303 N EAST ST TOLEDO IA 52342-1707	33.33
Individual	KUSSEROW, SHANNON	SSN	***-**-5711	17-May-1 985	64148578 13	405 E MADISON ST TOLEDO IA 52342-1715	33.33

Criminal History Details

Has anyone listed on the Ownership page been charged or convicted of a felony offense in Iowa or any other state of the United States?

No

Has anyone listed on the Ownership page been convicted of any violation of any state, county, city, federal or foreign law? For traffic violations, only include those that are drug or alcohol related.

No

Criminal Violations

Contact Information

Contact Name: SHANNON KUSSEROW

Phone Number: 6414857813

Email Address: luckywifewineslushies8@gmail.com

Address: 1869 295TH ST TOLEDO IA 52342-9502

Attestation Information

Attestation Name: SHANNON KUSSEROW

Attestation Date: 09-Apr-2026



**MARSHALLTOWN
MORE THAN EVER**

**Mike Ladehoff, Mayor
Carol Webb, City Administrator
24 North Center Street
Marshalltown, IA 50158
PH 641.754.5701 • FX 641.754.5717**

To: Mayor and City Council
From: Kelsie Stafford, Director
Meeting Date: May 11, 2026
Re: Resolution Approving a Professional Services Agreement not to exceed \$72,000 with Snyder & Associates for West End Park Phase II Project, #PRK26001

Strategic Plan Objective:

- Goal 2: Enhance Marshalltown's public image
- Goal 3: Continually improve and sustain the City's infrastructure, organization, and services.
- Goal 4: Partner with citizens, for-profit, non-profit and others to improve quality of life.

Recommended:

Staff recommends approval and execution of the agreement with Snyder & Associates for design and engineering professional services.

Budget Impact:

The Professional Services Agreement is a lump sum of \$70,000 for the scope of services to include project administration, topographic survey, preliminary and final engineering design, hydraulic modeling and environmental services, as well as an hourly not to exceed task totaling \$2,000. The table below outlines the current project costs and funding sources:

Project Expenses:

Concept/Design Engineering	\$72,000.00	Snyder & Associates
Construction Allowance	\$470,000.00	Bid Process
Construction Contingency	\$58,000.00	
TOTAL:	\$600,000.00	

Funding Sources:

2022 GO Bond \$600,000.00
(Fund 364)
TOTAL: \$600,000.00

Description/Background:

As part of the Franklin Field Renovation Project completed by Marshalltown Community School District (MCSD), the opportunity to install a trail-width sidewalk arose. MCSD proceeded to execute the installation of a Glow Trail that connects Franklin School and Franklin Field to 13th Street. A portion of this trail is routed on City property through West End Park and requires that the City of Marshalltown commit to continuing the trail through West End Park and installing a new bridge. This collaboration with MCSD would meet three of our Council strategic goals, expand walkable access to parking in the 13th Street District, address commitments in our Arts and Culture Master Plan, and assist with providing additional safe routes to school. This trail expansion is one piece of an overall preliminary plan to connect the 13th Street District to Miller Middle School and Iowa River's Edge Trail.

The Franklin School-West End Park Glow Trail will be the first trail in Iowa to use all four glow aggregate colors, and will be the third glow trail in the state. A new bridge/creek crossing will address maintenance challenges in the park and aid in upgrading the safety of the creek crossing.

West End Park Phase II Project originally planned for parking lot expansion and restroom installation. Staff is committed to gathering input from key stakeholders to determine priorities for the remainder of West End Phase II, if applicable, and will plan to allocate future bond proceeds to continue development in West End Park. City Council endorsed this shift in priorities when first presented in July 2025 and as part of the FY27 Capital Improvement Plan approval process.

Following City Council approval, Snyder & Associates will begin design and engineering work on the project, subject to Army Corp of Engineers approval. Staff anticipates that construction bids will be let in late summer or early fall of 2026 with construction completion in spring of 2027.

Attachments:

1. 2026-05-11_2026-094_Resolution Approving Snyder & Associates for PRK26001 West End Park Phase II
2. PSA_2025-04-24_GlowTrail&Bridge

RESOLUTION APPROVING A PROFESSIONAL SERVICES AGREEMENT NOT TO EXCEED \$72,000 WITH SNYDER & ASSOCIATES FOR WEST END PARK PHASE II PROJECT, #PRK26001

WHEREAS, the City of Marshalltown desires to execute West End Park Phase II Project No. PRK26001; and

WHEREAS, the City of Marshalltown, Iowa, has negotiated an agreement for professional services with Snyder & Associates for Professional Engineering Services to include engineering design and construction plan development for a pedestrian trail and crossing of Braddy Creek; and

WHEREAS, the City Council of Marshalltown finds that this agreement for professional services is in the best interest of the City.

NOW, THEREFORE, BE IT RESOLVED BY THE CITY COUNCIL OF THE CITY OF MARSHALLTOWN, IOWA, that the Professional Services Agreement with Snyder & Associates for the scope, for a not to exceed compensation of \$72,000, is hereby approved and the Mayor is directed to execute the Agreement.

Passed this 11th day of May, 2026, and signed this _____ day of May, 2026.

CITY OF MARSHALLTOWN, IOWA

Mike Ladehoff, Mayor

ATTEST:

Alicia Hunter, CMC, City Clerk

NOW ON THIS _____ day of _____, 2026, **Snyder & Associates, Inc.**,
2727 SW Snyder Blvd., P.O. Box 1159, Ankeny, IA 50023, (hereinafter, Professional), and
City of Marshalltown

(hereinafter, Client) do hereby agree as follows:

1. **PROJECT:** Professional agrees to provide Professional Services (Services) for Client's project known and identified as: WEST END PARK GLOW TRAIL AND BRIDGE
2. **SCOPE AND FEES:** The Scope of and the fees to be paid for said Services are set forth on Exhibit A attached hereto and by this reference made a part of this Agreement. Any Services not shown on Exhibit A shall be considered Additional Services. Additional Services may only be added by written change order, amendment or supplement to this agreement signed by both parties.
3. **TIMELINESS:** Professional will perform its services with reasonable diligence and expediency consistent with sound professional practices and within the time period(s), if any, set forth in Exhibit A.
4. **STANDARD OF CARE:** In providing Services under this Agreement, the Professional shall perform in a manner consistent with that degree of care and skill ordinarily exercised by members of the same professional discipline currently practicing under similar circumstances at the same time and in the same or similar locality. Professional makes no warranty, express or implied, as to its professional services rendered under this Agreement. Client shall promptly report to Professional any defects or suspected defects in the Professional's Services of which Client becomes aware. Withholdings, deductions or offsets shall not be made from the Professional's compensation for any reason unless the professional has been found to be legally liable for such amounts by a court of competent jurisdiction.
5. **INVOICE, PAYMENT, INTEREST, SUSPENSION:** Professional shall prepare invoices in accordance with its standard invoicing practices and submit the invoice(s) to Client on a monthly basis. Client agrees to timely pay each invoice within 30 days of the invoice date. Payments not paid within said 30 days shall accrue interest on unpaid balances at the rate of 1.5% per month (or the maximum rate of interest permitted by law, if less) from said 30th day. In addition, Professional may, after giving 7 days written notice to Client, suspend services under this Agreement until Professional has been paid in full for Services, interest, expenses and other related charges rendered, accrued, advanced and/or incurred by Professional to the date of suspension. Client waives any and all claims against Professional arising out of or resulting from said suspension. Payments will be credited first to interest, then to expenses, then to principal.
6. **RELIANCE:** The Client shall furnish, at its expense, all information, requirements, reports, data, surveys and instructions required by this Agreement and Professional may use such furnished information and material in performing its services and is entitled to rely upon the accuracy and completeness thereof. The Professional shall not be held responsible for any errors or omissions that may arise as a result of erroneous or incomplete information provided by the Client and/or the Client's consultants and contractors.
7. **ASSIGNMENT:** Client shall not transfer, sublet or assign any rights or duties under or interest in this Agreement, without the prior written consent of Professional.
8. **OWNERSHIP OF INSTRUMENTS OF SERVICE:** All reports, drawings, specifications, electronic and hard copy files, field data, notes and other documents and instruments prepared by Professional for the Project are acknowledged to be instruments of service and shall remain the property of the Professional. The Professional shall retain all common law, statutory and other reserved rights, including, without limitation, the copyrights thereto. If Professional agrees to allow transfer of its electronic media file(s), Client understands and agrees that as a condition precedent, it will sign the Professional's "Electronic Media Transfer Agreement" form prior to the transfer of an electronic media file.

ADDITIONAL TERMS AND CONDITIONS

- 9. **MUTUAL INDEMNIFICATION:** The Professional and the Client mutually agree, to the fullest extent permitted by law, to indemnify and hold each other harmless from any and all damages, liabilities or costs, including reasonable attorneys’ fees and defense costs, arising from their own negligent acts, errors or omissions, or willful misconduct in the performance of their services, duties and responsibilities under this Agreement, to the extent that each party is responsible for such damages, liabilities and costs on a comparative basis of fault.
- 10. **MUTUAL WAIVERS:** Notwithstanding any other provision of this Agreement, and to the fullest extent permitted by law, neither the Client nor the Professional, their respective officers, directors, partners, employees, contractors or subconsultants shall be liable to the other or shall make any claim for any incidental, indirect or consequential damages arising out of or connected in any way to the Project or to this Agreement.
- 11. **LIMITATION:** In allocating the risks of this Project and notwithstanding any other provision of this Agreement, the Client agrees to limit, to the maximum extent permitted by law, the Professional’s liability for the Client’s damages to the aggregate sum of the Professional’s fee for this Project. This limitation shall apply regardless of the cause of action or legal theory pled or asserted.
- 12. **DISPUTE RESOLUTION:** Any disputes that arise during the Project or following the completion of the Project will be resolved by representatives from each party who have authority to settle. Those issues not resolved shall be submitted to formal nonbinding mediation prior to submission to a court of competent jurisdiction. Each party shall endeavor to include a similar dispute resolution in all agreements with other consultants, contractors and subcontractors of any tier who are retained for the project so that formal mediation is required as the primary form of dispute resolution.
- 13. **SEVERABILITY:** If any term or provision of this Agreement is held to be invalid or unenforceable under any applicable statute or rule of law, such holding shall be applied only to the provision so held, and the remainder of this Agreement shall remain in full force and effect.
- 14. **SURVIVAL:** Notwithstanding completion or termination of this Agreement for any reason, all rights duties and obligations of the parties to this Agreement shall survive such completion or termination and remain in full force and effect until fulfilled.
- 15. **GOVERNING LAW AND JURISDICTION:** The Client and the Professional agree that this Agreement and any legal actions concerning its validity, interpretation and performance shall be governed by the laws of the State of Iowa, without regard to any conflict of laws provisions, which may apply the laws of other jurisdictions. It is further agreed that any legal action between the Client and the Professional arising out of this Agreement or the performance of the services shall be brought in a court of competent jurisdiction in the State of Iowa.
- 16. **ATTORNEYS FEES, COSTS:** In the event legal action is necessary to enforce the payment terms of this Agreement, Professional shall be entitled to collect from Client and Client agrees to pay to Professional any judgment or settlement sum(s) due, plus reasonable attorneys’ fees, court costs and other expenses incurred by Professional for such collection action and, in addition, the reasonable value of the Professional’s time and expenses spent for such collection action, computed according to the Professional’s prevailing fee schedule and expense policy.
- 17. **INCORPORATION BY REFERENCE:** It is understood and agreed that the provisions of the following attached Exhibits are incorporated herein and by this reference made a part of this Agreement:

Exhibit A Scope of Work

Exhibit B Fee Schedule

Exhibit C Subconsultant Scope

Exhibit

(Client)

SNYDER & ASSOCIATES, INC. (Professional)

By: _____
(Authorized agent)

By: _____
(Authorized agent)

(Printed or typed signature)

Mark A. Land, P.E., CFM
(Printed or typed signature)

Route executed copy to: TNJ

EXHIBIT A**WEST END PARK GLOW TRAIL AND BRIDGE**

CLIENT: MS. KELSIE STAFFORD
CITY OF MARSHALLTOWN
24 NORTH CENTER STREET
MARSHALLTOWN, IOWA 50158

PROFESSIONAL: SNYDER & ASSOCIATES, INC.
2727 SW SNYDER BLVD
ANKENY, IOWA 50023

DATE: April 24, 2026

PROJECT DESCRIPTION

This project is to provide engineering design and construction plan development for a new pedestrian trail through West End Park in the City of Marshalltown. The project will include design of an 8-foot wide PCC pedestrian trail and crossing of the Braddy Creek. The pedestrian trail shall include design accommodations for glow aggregate. The project to review design alternatives including either bridge or culvert(s) for the Braddy Creek crossing.

Services include topography survey, engineering design, geotechnical investigation, environmental survey, hydraulic design, project specifications and bit letting.

Construction phase services including construction administration, construction observation, and construction staking, are not included in this scope, but may be added by supplemental scope of services.

SCOPE OF SERVICES**I. PROJECT ADMINISTRATION**

- A. **DESIGN SCHEDULE** – The PROFESSIONAL and CLIENT shall mutually agree to a project schedule in conformance with the CLIENT’S funding schedule. The project is anticipated to be let in 2026. PROFESSIONAL will attempt to achieve the desired schedule; it is recognized that reviews by various agencies, if necessary, are outside PROFESSIONAL’S control, and that cooperation by these agencies is essential to meet the project schedule.

- B. PROGRESS AND BILLING REPORT – The PROFESSIONAL shall provide the CLIENT with a monthly progress report. If design work is not progressing in a manner to comply with the anticipated completion date, the project team including the PROFESSIONAL and the CLIENT will develop an action plan to reduce or eliminate any delays in completing the design in accordance with the agreed upon schedule. If substantial delays occur which are beyond the PROFESSIONAL’S control, the schedule will be adjusted to provide adequate design time for plan completion.

II. TOPOGRAPHIC SURVEY

- A. Topographic Survey and Site Features – The PROFESSIONAL shall provide topographic survey within the project limits. This service includes:
1. Horizontal Datum will be provided using the Ia Regional Coordinate System – Zone 9.
 2. Vertical Datum will be provided using the North American Vertical Datum of 1988 (NAVD88).
 3. Set a minimum of one permanent benchmark on site with description and elevation to the nearest 0.01 foot. Larger sites will require benchmarks at intervals not to exceed 1000 feet horizontal or 25 feet vertical. Three control points will be set.
 4. Spot elevations displayed to the nearest 0.01 feet to be included for shots and are to be shown on a separate cadd drawing level to view when applicable. An approximate 50 grid will be used to create topography map along with other grade breaks such as tops, toes, drainage ways, tops and bottoms of retaining walls, etc.
 5. Contours shall be shown at 1-foot intervals.
 6. Perform a field survey locating visible improvements such as structures, parking, signs, sidewalks and other visible features above grade will be shown. Below grade non-visible structures or improvements will be shown from information as provided by site owner and would be approximate. Below grade non-visible structures may require further investigation if potentially in conflict with proposed site improvements. Existing building structure shown are not intended for architectural design or civil site plan design. Specific information required for that purpose should be provided by a specific scope of services. However, this service can be provided upon request with additional fees.

7. Rim elevations for existing utility structures will be provided, if accessible. The surveyor will use their experience and judgment in obtaining the inverts, pipe diameter, pipe material and condition of structure obtained by using reasonable survey equipment and visual inspection of the structure. Due to the nature of underground utilities, the surveyor cannot guarantee the accuracy when physical measurements cannot be obtained.

Should it be determined that more investigation of the utility is necessary, the Client shall contact PROFESSIONAL to authorize additional investigation of a specific utility. This may include but not limited to geophysical locating, opening manholes rims that have been paved over/locked down/unable to open, private utilities, entering a structure that is considered a confined space, etc. This service is not included with the base fee amount and will be considered extra services.

8. Location of trees 6 inches and greater not lying with wooded area will be noted as deciduous or coniferous.
9. The drip line or perimeter outline of wooded/brush areas will be shown.

B. EXISTING UTILITY MAPPING

PROFESSIONAL shall provide known existing utility information based on record information, surface evidence, as-built drawings and utility company field locates. This service includes, contacting Iowa One Call, following Chapter 480 of the Iowa Code, to locate existing public utilities on the site; perform a field survey locating visible utilities and the location of below grade utility locates by Iowa One Call. Private utility locates are not included with this service and if known will be shown as map location. Specific information required for that purpose should be provided by a specific scope of services. However, this service can be provided upon request with additional fees. This service of utilities shown in conjunction with ASCE Standard CI/ASCE 38-22 constitute a Quality Level “C” Subsurface Utility Engineering survey as outlined below.

Quality Level A involves the use of nondestructive digging equipment at critical points to determine the precise horizontal and vertical position of underground utilities, as well as the type, size, condition, material, and other characteristics. This activity is called “locating.” It is the highest level presently available. When surveyed and mapped, precise plan and profile information is available for use in making final design decisions. By knowing exactly where a utility is positioned in three dimensions, the designer can often make small adjustments in elevations or horizontal locations and avoid the need to relocate utilities. Additional information such as utility material, condition, size, soil contamination, and paving thickness also assists the designer and utility owner in their decisions.

Quality Level B involves the use of surface geophysical techniques to determine the existence and horizontal position of underground utilities. This activity is called “designating”. Two-dimensional mapping information is obtained. This information is usually sufficient to accomplish preliminary engineering goals. Decisions can be made on where to place storm drainage systems, footings, foundations, and other design features in order to avoid conflicts with existing utilities. Slight adjustments in the design can produce substantial cost savings by eliminating utility relocations.

Quality Level C involves surveying visible above-ground utility facilities, such as manholes, valve boxes, posts, etc., and correlating this information with existing utility records. When using this information, it is not unusual to find that many underground utilities have been either omitted or erroneously plotted. Its usefulness, therefore, should be confined to rural projects where utilities are not prevalent, or are not too expensive to repair or relocate.

Quality Level D information comes solely from existing utility records. It may provide an overall “feel” for the congestion of utilities, but it is often highly limited in terms of comprehensiveness and accuracy. Its usefulness should be confined to project planning and route selection activities.

III. PRELIMINARY AND FINAL CIVIL ENGINEERING DESIGN

- A. PRELIMINARY DESIGN - All plans shall be prepared in MicroStation and formatted to fit on 11” x 17” size paper at a scale of 1” = 100’. The PROFESSIONAL shall provide files in Civil 3d if requested by the CLIENT. The preliminary plans shall at a minimum include the streambank restoration plan and bridge type, size, and location plan incorporated from the structural design task.
- B. FINAL CIVIL DESIGN – The PROFESSIONAL shall prepare construction documents for the PROJECT. Construction specifications will be per Iowa SUDAS as amended by City of Marshalltown Supplemental Specifications. The plans shall include the following details necessary for a Local Bid Letting and project construction:
 - 1. Title Sheet
 - 2. General project notes, estimated construction quantities, and estimate reference information
 - 3. Storm water pollution prevention plan (SWPPP) general notes and supplementary information, as required
 - 4. Typical sections including construction materials, subgrade work, and general details

5. Plan and profile sheets with horizontal alignment and vertical profile, construction limits as needed for trail approach pavement
6. Existing property lines using available county parcel data.
7. Structural design and plans
8. Survey sheets including benchmarks and survey control
9. Traffic control plan, staging notes, and path closures.
10. No permanent or temporary construction easement acquisition areas are anticipated with this project.
11. No Special Provisions are anticipated with this project

C. STRUCTURAL DESIGN – PROFESSIONAL shall review drainage features for the trail crossing of Braddy Creek. Options to be discussed with CLIENT for preferences. Reviewed structures to include prefabricated bridge & abutments, reinforced box culvert, multiple RCPs, and aluminum culvert. The review will include cost estimates and impact comparisons. The selected option shall be included in the construction documents.

D. CONSTRUCTION SPECIFICATIONS – PROFESSIONAL shall prepare specifications utilizing Iowa SUDAS and contract documents. PROFESSIONAL shall incorporate any CLIENT specific specifications as requested.

E. OPINION OF PROBABLE CONSTRUCTION COSTS – The PROFESSIONAL shall prepare a statement of the total probable cost for the PROJECT, including structural components, based upon the design developed using identified bid items and estimated quantities. Costs are intended for budgetary purposes only.

1. Statements of probable construction costs prepared by the PROFESSIONAL represent the best judgment as a design professional familiar with the construction industry. Opinions of probable construction costs for this project will be based on history of similar projects and current Iowa DOT unit costs.
2. It is understood that quantities are estimated only; exact quantities cannot be determined until the time of construction. Exact costs cannot be determined due to the nature of estimates of quantities, specialized nature of some repair items, work being affected by the rivers or streams, the possibility of hidden or latent structure conditions, site accessibility, and future market conditions.

3. It is recognized that the PROFESSIONAL has no control over the cost of labor, materials or equipment, over the Contractor's methods of determining bid prices, or over competitive bidding. Accordingly, the PROFESSIONAL does not guarantee that any actual cost will not vary from any cost estimate prepared by the PROFESSIONAL.

F. NPDES PERMIT – If needed, PROFESSIONAL will file a Notice of Intent for National Pollutant Discharge Elimination System (NPDES) Coverage Under General Permit #2 Storm Water Discharge Associated with Construction Activities for publication in a local newspaper. Upon receipt of the affidavit of publication, PROFESSIONAL will submit an application for a three-year permit to the Iowa Department of Natural Resources.

IV. ENVIRONMENTAL SERVICES

- A. The PROFESSIONAL will provide a Wetland & Stream Delineation for the proposed trail project. The Wetland Delineation will determine the upper boundaries of wetland areas at the project site. The Stream Delineation will evaluate the Ordinary Highwater Mark (OHWM) within the project area. The PROFESSIONAL will utilize information from the initial wetland review. One site visit will be performed to gather data pertaining to wetland vegetation, wetland hydrology, and hydric soils as well as OHWM characteristics. The upper boundary of each wetland will be surveyed. Fieldwork will be conducted in accordance with procedures outlined in the 1987 U.S. Army Corps of Engineers Wetland Delineation Manual and Midwest Supplement. The PROFESSIONAL will provide copies of the wetland delineation report.
- B. The PROFESSIONAL will submit an application to the Regulatory Request System if temporary or permanent impacts to Waters of the United States (WOTUS) are required for the proposed trail. The PROFESSIONAL will act as the Authorized Agent throughout the permitting process. During this process, the PROFESSIONAL will respond to inquiries from the U.S. Army Corps of Engineers. This task assumes a Nationwide Permit (NWP) will be obtained from the USACE with little to no mitigation requirements.

V. HYDRAULIC MODEL

- A. The PROFESSIONAL shall perform hydraulic design for the proposed crossing of Braddy Creek which is a tributary of the Iowa River. The project is located within a Zone AE Special Flood Hazard Area in an incorporated area with a drainage area less than 2 square miles. Therefore, an Iowa DNR Flood Plain Development Permit will not be required. The following procedure shall be utilized:

1. The trail crossing is located within the regulatory floodway of Braddy Creek and the proposed modifications will be sized to meet a “No Rise” condition to the base flood elevation.
2. Freeboard and backwater will be calculated and compared to the DNR Flood Plain Development recommendations.
3. The effective base hydraulic model of Braddy Creek will be obtained from the FEMA project library and will be used as the basis for analysis.
4. The Annual Exceedance Probability Discharges (AEPD) published in the Marshall County, Iowa Flood Insurance Study (IFS) will be utilized for analysis. The 0.5% (200 Year) will be interpolated from the published discharges at the project location. No additional hydrologic calculations will be performed.
5. The effective FEMA hydraulic model will be duplicated at the project site for the purpose of this analysis.
6. The duplicate effective model will be reviewed against current conditions. Any necessary corrections to the model will be incorporated as necessary to a corrective effective model.
7. The duplicate\corrective model will be copied and modified to remove the existing bridge and restore the cross sections at the bridge to a natural, pre-developed condition. The pre-developed model will be used as the baseline for determining if the proposed project meets freeboard and backwater requirements.
8. A post project model will be prepared that includes the proposed trail crossing modifications. The post project model will be compared to the duplicate\corrective effective model to determine if the “No Rise” criteria are met.
9. A scour analysis will be performed using the post project model if a bridge is the chosen replacement structure. The design scour discharge (0.5% annual chance flood) will be interpolated from the previously developed design discharges. Scour calculations will be consistent with the Iowa DOT Bridge Design Manual.
10. A report of the hydraulic analysis will be prepared. Local flood plain permit applications may be prepared as additional services, if required.
11. Preparation of materials and submittals to FEMA for either a Conditional or Final Letter of Map Revision (LOMR) are not included as part of this scope and are considered additional services.

VI. BID PERIOD ASSISTANCE FOR LOCAL LETTING

- A. Upon receipt of CLIENT authorization, the PROFESSIONAL shall perform the following services for a local letting:

1. The project will be let by the CLIENT and the PROFESSIONAL shall supply the necessary documents for this process. It is the PROFESSIONAL'S understanding that the CLIENT will handle the advertising requirements and the soliciting of bids will be through the CLIENTS City website.
2. The PROFESSIONAL shall assist the CLIENT in clarification of the plan design and issue addenda as required per an hourly not-to-exceed basis.

VII. DELIVERABLES

The scope of services for shall be considered to be complete upon delivery of the following items:

- Geotechnical Report by SUBCONSULTANT
- Environmental Study Reports
- Hydraulic Study report
- Final plans & Project Manual / Specifications
- Opinions of Probable Construction Cost
- NPDES Permit
- Local Floodplain Permit

VIII. COMPENSATION

The professional service fee will be on the basis of a Lump Sum and Hourly Not-To-Exceed as outlined in the PROFESSIONAL'S Standard Fee Schedule. The current fee schedule is shown in the attached Exhibit B.

Project Task	Lump Sum
Task I – Project Administration	\$5,200
Task II – Topographic Survey	\$4,000
Task III – Preliminary and Final Engineering Design	\$42,800
Task IV – Hydraulic Modeling	\$12,000
Task V – Environmental Services	\$6,000
Total Lump Sum	\$70,000
Task VI – Bid Period Assistance for Local Letting	\$2,000
Total Hourly Not-To-Exceed	\$2,000
Total	\$72,000

Total fees for services shall not exceed the above total without approval of the CLIENT. If the PROFESSIONAL anticipates that actual costs will exceed estimated costs, or additional services are necessary, the PROFESSIONAL shall immediately notify the CLIENT, in writing, of such proposed increase and the reasons therefore. The CLIENT shall thereupon review such proposed increase and either accept or reject it.

IX. ADDITIONAL SERVICES

- A. Geotechnical Investigation - If a prefabricated bridge is selected for the Braddy Creek crossing, upon authorization from the CLIENT, the PROFESSIONAL shall obtain a subconsultant for geotechnical investigation services. The anticipated Lump Sum fee amount for Geotechnical Investigation is \$5,200.00.
- B. The CLIENT may request Additional Services from the PROFESSIONAL that are not included in the Scope of Services as outlined. Authorization for additional services shall be evident by the CLIENT in writing in the form of a supplemental agreement. Any item requested by the CLIENT that expands the scope of the project and work to be completed may be considered additional services.
- C. Additional Services may include, but are not limited to:
 - 1. Client-requested meetings in addition to those specified herein
 - 2. Client-requested major revisions
 - 3. Extensive structural modifications or reinforcing for unforeseen conditions
 - 4. NEPA documentation
 - 5. DNR Floodplain permitting
 - 6. Landscape architecture and aesthetic design elements
 - 7. Boundary survey
 - 8. Temporary or permanent easement plats
 - 9. Submittal fees to any and all regulatory or permitting agencies or jurisdictions.
 - 10. Testing fees
 - 11. Construction staking
 - 12. Construction administration
 - 13. Construction observation



SNYDER
& ASSOCIATES

EXHIBIT B 2025 STANDARD FEE SCHEDULE

Professional | Engineer, Landscape Architect, Land Surveyor, GIS, Environmental Scientist, Project Manager, Planner, Archaeologist, Right-of-Way Agent, Graphic Designer

BILLING CLASSIFICATION/LEVEL	BILLING RATE
Principal II	\$269.00/hour
Principal I	\$246.00/hour
Senior	\$225.00/hour
VIII	\$206.00/hour
VII	\$194.00/hour
VI	\$185.00/hour
V	\$173.00/hour
IV	\$159.00/hour
III	\$147.00/hour
II	\$133.00/hour
I	\$120.00/hour

Technical | CAD, Survey, Construction Observation

BILLING CLASSIFICATION/LEVEL	BILLING RATE
Lead	\$156.00/hour
Senior	\$150.00/hour
VIII	\$139.00/hour
VII	\$129.00/hour
VI	\$116.00/hour
V	\$105.00/hour
IV	\$95.00/hour
III	\$85.00/hour
II	\$78.00/hour
I	\$69.00/hour

Administrative

BILLING CLASSIFICATION/LEVEL	BILLING RATE
II	\$80.00/hour
I	\$66.00/hour

Reimbursables

BILLING CLASSIFICATION/LEVEL	BILLING RATE
Mileage	<i>Current IRS Standard Rate</i>
Outside Services	<i>As Invoiced</i>

ALLENDER BUTZKE ENGINEERS INC.



GEOTECHNICAL • ENVIRONMENTAL • CONSTRUCTION Q. C.

STANDARD AGREEMENT FOR PROFESSIONAL SERVICES

PROJECT NAME: Trail Bridge over Braddy Creek **PN:** 251344
PROJECT ADDRESS: Tankersly Park
Marshalltown, IA
CLIENT: Snyder & Associates, Inc. Attn: Tyler Jensen, PE
ADDRESS: 2727 SW Snyder Blvd.
Ankeny, IA 50023

SCOPE: - Mobilization with truck drilling equipment, utility locations (Iowa One Call), drill and sample 1 abutment test borings 30+/- feet deep, 1 hand auger boring 10+/- feet deep in streambed, laboratory testing, engineering analysis (including soil bearing pressure and settlement estimates of precast abutment foundation) and written report.

COMPENSATION TERMS: The total cost for the above scope of services will be \$5,200.00. Consultation subsequent to completion of report invoiced at current engineering rates of Principal Engineer-\$232/hr., Project Engineer -\$182/hr. and Staff Engineer -\$156/hr.

REMARKS: Field exploration could be scheduled to be conducted within one to two weeks of receiving authorization, weather permitting. A verbal report of our findings and recommendations will be available one week after drilling, followed one to two weeks later with the written report. ABE will contact Iowa One Call for public utility locates. We have assumed the boring could be accessed from nearby streets with a truck drill. If access or ground conditions require an ATV drill rig an additional cost of \$500 would be incurred.

Services covered by the Agreement will be performed in accordance with the current Snyder & Associates and Allender Butzke Engineers Inc. RECIPROCAL MASTER AGREEMENT FOR SUBCONTRACTED PROFESSIONAL SERVICES and any attachments or schedules. This Agreement supersedes all prior agreements and understandings and may only be changed by written amendment executed by both parties.

PROPOSED BY ABE INC.

ACCEPTED FOR CLIENT

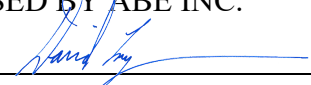
By: 
David Logemann, P.E.

By: _____
Printed Name

Title: Senior Principal Engineer

Title: _____

Date: September 11, 2025

Date: _____

PLEASE SIGN AND RETURN ACCEPTANCE AGREEMENT TO OUR OFFICE, THANK YOU!
1 Email Above



**MARSHALLTOWN
MORE THAN EVER**

**Mike Ladehoff, Mayor
Carol Webb, City Administrator
24 North Center Street
Marshalltown, IA 50158
PH 641.754.5701 • FX 641.754.5717**

To: Mayor and City Council
From: Deb Millizer, Housing & Community Development Director
Meeting Date: May 11, 2026
Re: Public Hearing for a Marshalltown Community Development and Housing Needs Assessment, Review of the Application for Community Development Block Grant (CDBG) Derecho Disaster Funds and Authorize ECICOG to Submit the CBDG-DR Application

Strategic Plan Objective:

Housing and Neighborhood Revitalization

This project supports the City's strategic goal of expanding housing opportunities, encouraging reinvestment in existing neighborhoods, and promoting infill development. The proposed CDBG DR application would help create new affordable for sale housing for low to moderate income households while supporting long term recovery from the 2020 derecho.

Recommended:

Staff recommends Council hold the public hearing, receive any public comments, close the public hearing, and approve the resolution authorizing ECICOG to submit the CDBG-DR application and authorizing the Mayor to sign all required application documents.

Budget Impact:

If awarded, CDBG-DR funds would support eligible project costs for the construction of new affordable-for-sale housing. Any future development agreement, land transfer, local match, or City financial commitment will return to Council for separate consideration.

The City's current action is limited to holding the required public hearing, authorizing submission of the application, and authorizing the Mayor to sign application-related documents.

Description/Background:

The City of Marshalltown is working with East Central Iowa Council of Governments, ECICOG, to

submit an application to the Iowa Economic Development Authority for Community Development Block Grant Disaster Recovery, CDBG DR, New Production For Sale Housing funds.

As part of this agenda item, Council will hold the required public hearing for the proposed CDBG-DR application and the Marshalltown Community Development and Housing Needs Assessment. The public hearing gives residents an opportunity to provide input on the proposed project, identified housing needs, funding source, proposed application submission, amount of federal funds requested, benefits to low and moderate income households, project location, displacement considerations, and the overall nature of the project.

The proposed project would support construction of new affordable-for-sale housing units on infill sites in Marshalltown. All homes funded through the program would serve low and moderate-income households. The project supports long-term recovery from the August 10, 2020 derecho, which affected housing conditions, housing availability, and community recovery needs in Marshall County.

The City's Community Development and Housing Needs Assessment identifies several local housing priorities, including affordable workforce housing, owner-occupied housing options, home buyer assistance, rental housing quality and availability, public infrastructure improvements, neighborhood revitalization, code-related improvements, and continued infill development.

The proposed CDBG-DR application aligns with the City's housing goals by supporting new owner-occupied housing opportunities, reinvestment in existing neighborhoods, and access to homeownership for income-qualified households.

After the public hearing is opened, public comments are received, and the hearing is closed, Council will consider a resolution authorizing ECICOG to submit the CDBG-DR application and associated documents to IEDA. The resolution also authorizes the Mayor to sign application-related documents on behalf of the City.

Attachments:

1. 2026-05-11_2026-095_Resolution authorizing ECICOG to submit the CDBG DR application
2. CDBG Public Hearing Notice - Marshalltown
3. Community Development and Housing Needs Assessment
4. CDBG DR Application Certifications and Assurances
5. Attorney General Contractor Fraud Checklist

RESOLUTION AUTHORIZING AND DIRECTING EAST CENTRAL IOWA COUNCIL OF GOVERNMENTS (ECICOG) TO SUBMIT APPLICATION AND ASSOCIATED DOCUMENTS FOR FUNDING FOR THE COMMUNITY DEVELOPMENT BLOCK GRANT DISASTER RECOVERY HOUSING PROGRAM (CDBG DR) - TO THE IOWA ECONOMIC DEVELOPMENT AUTHORITY

WHEREAS, on August 10, 2020 communities in Marshall County, Iowa experienced a derecho storm that significantly impacted the condition and availability of rental and owner housing throughout the county; and

WHEREAS, the City Council of Marshalltown has heretofore deemed it necessary and desirable to apply for a grant through the CDBG DR Program to the Iowa Economic Development Authority (IEDA) for New Production For-Sale Housing (PROJECT); and

WHEREAS, the City Council of Marshalltown is supportive of the PROJECT, which will create new for-sale housing units on in-fill sites in Marshalltown, with all homes designated for low-to-moderate income households; and

WHEREAS, the City of Marshalltown held a public hearing on May 11, 2026 to discuss a. How the need for the proposed activity was identified, b. Source of funding, c. Date the application will be submitted, d. Amount of federal funds to be requested, e. Portion of federal funds benefiting low-to-moderate income households, f. Location of proposed activity, g. Plans to minimize displacement of persons or businesses from funding activity, h. Plans to assist those displaced, and i. The nature of the project as part of the application process; and

WHEREAS, the public hearing provided an opportunity for public input for the development of the Community Development and Housing Needs Assessment, which is hereby adopted; and

WHEREAS, accordingly, a grant application is being prepared and documents have been presented to the City Council of Marshalltown for the approval necessary to submit the grant application.

NOW, THEREFORE, BE IT RESOLVED BY THE COUNCIL OF THE CITY OF MARSHALLTOWN, IOWA: that the Mayor is hereby authorized and directed to sign and execute on behalf of the City of Marshalltown, all additional documents required for the application, and ECICOG is hereby authorized to submit the CDBG-DR application and the associated documents for the above named project to the Iowa Economic Development Authority on or before the date established by IEDA.

Passed this 11th day of May 2026, and signed this _____ day of May 2026.

CITY OF MARSHALLTOWN, IOWA

Mike Ladehoff, Mayor

ATTEST:

Alicia Hunter, CMC, City Clerk

City of Marshalltown
PUBLIC HEARING NOTICE

The City Council of the City of Marshalltown will hold a public hearing to discuss applications for Community Development Block Grant Disaster Recovery (CDBG-DR) housing funds from the Iowa Economic Development Authority. These funds will be used to construct new single-family housing for eligible low-to-moderate income households.

Discussion at the public hearing will include: a. How the need for the proposed activities was identified, b. Source of funding, c. Date the application will be submitted, d. Amount of federal funds to be requested, e. Portion of federal funds benefiting low-to-moderate income households, f. Location of proposed activities, g. Plans to minimize displacement of persons or businesses from funding activities, h. Plans to assist those displaced, and i. The nature of the proposed project.

The public hearing will also gather public input for a Community Development and Housing Needs Assessment, including: a. A description of the housing market in the community, b. Disaster recovery and housing improvement activities completed within the last 5 years that promote or compliment the objectives of this proposal, c. Description of the impact the project will have on disaster recovery, including explanation of how the proposed project coincides with current/planned community development and disaster recovery projects, and d. Any input from the public that may inform the Community Development and Housing Needs Assessment.

The Public Hearing will be held Monday, May 11, 2026, at 5:30 p.m. at Marshalltown City Hall, located at 10 W. State Street, Marshalltown, Iowa. The City of Marshalltown will conduct all CDBG-DR related public hearings in a public building that is accessible to the disabled. Non-English-speaking persons requiring translators or written translation after the public hearing should contact the City at (641) 754-5701 to request accommodation.

For more information, contact Deb Millizer, Housing & Community Development Director, at (641) 754-5756 x3100.

For technical assistance to groups representative of Low to Moderate Income Households in preparing and presenting proposals for the use of federal funds, you may contact Paula

Mitchell of ECICOG at 319-289-0071 or
paula.mitchell@ecicog.org.

Community Development and Housing Needs Assessment
City of Marshalltown

The needs of low-and-moderate income persons in Marshalltown were determined using a combination of public data and city records, including the *Reimagine Marshalltown Housing Market Analysis and Action Strategy (2026)*, *Comprehensive Plan 2030*, *Downtown Master Plan (2019)*, recent Marshalltown City Council discussions, as well as 2018-2022 data from the Housing and Urban Development (HUD) Comprehensive Housing Affordability Strategy (CHAS), U.S. Census American Community Survey 5-year Estimates. Additionally, input from community stakeholders including city and county officials, staff, and local housing and economic development organizations were incorporated to validate data findings and identify unmet community needs.

Community Development and Housing Needs of Low- to Moderate-Income Persons

High Priority: Increase housing supply across price points, including affordable and workforce housing. *Comprehensive Plan 2030*: “Land-Use Housing Goal 1: Provide a variety of housing types, densities and choices to meet the lifecycle needs of residents.” Marshalltown is projected to need approximately 600 additional units by 2035, or 60 units annually, to meet population and workforce demand. Community insights gathered during the *Reimagine Marshalltown* visioning process indicated a lack of housing for mid-income families in the \$225,000 to \$350,000 price range, a mismatch between size and type of current housing and the current population needs, a lack of starter homes for young professionals, and renovated low-cost homes. Limited supply at these price points restricts mobility within the housing market and constrains workforce attraction and retention. City officials have identified the need to construct at all price points and support this goal through zoning, permitting, and technical assistance.

High Priority: Preservation and rehabilitation of existing affordable owner-occupied housing. This is supported by the City’s stated goal of maintaining safe and affordable housing stock and the continuing need for critical repairs. Approximately 78% of Marshalltown’s housing stock was constructed prior to 1980 and 3,288 of those units were built prior to 1939. Applying standard lifecycle assumptions, it is estimated that 40-70% of these units are likely in need of rehabilitation. In Marshalltown, approximately 36% of homeowners have income below 80% of area median income (AMI) and an estimated 1,110 of those homeowners are cost burdened, paying greater than 30% of household income on housing. Lower home values, median \$127,700, may limit homeowners’ ability to finance major repairs, reinforcing the need for rehabilitation programs. Older neighborhoods, particularly near downtown, experience higher concentrations of housing condition issues and deferred maintenance. Continued reinvestment is critical to stabilize neighborhoods and prevent further deterioration.

High Priority: Senior and accessible housing options. An aging population is increasing demand for low-maintenance, accessible housing, with an estimated need for 136 additional senior-oriented units by 2035.

High Priority: First-time homebuyer/down payment assistance for LMI households. A substantial share of renter households have incomes that position them as potential first-time

homebuyers, with 64% earning more than \$50,000 which is well above the statewide median renter income of \$43,900. Specifically, an estimated 794 renter households earn between \$50,000 and \$74,999, 424 earn between \$75,000 and \$99,999, and 508 earn over \$100,000 annually. With a median rent of \$891 many of these households may be financially positioned to transition to homeownership with targeted down payment and closing cost assistance as limited savings and rising home costs remain barriers.

High Priority: Rental housing quality and availability. The rental market is described as tight, with limited vacancies and concerns regarding the quality of lower-cost units according to the recently completed community housing survey. Families and workforce households face limited options for multi-bedroom rentals.

High Priority: Water Distribution System and Sanitary Sewer Improvements. Marshalltown Water Works (MWW) has identified the replacement of aging water mains and system components as a core, ongoing infrastructure need tied to reliability, leakage reduction, and public safety. Current projects include the replacement of the water main and storm sewer systems adjacent to West High School and on Main Street. A grant application for airport sanitary sewer system improvements was recently submitted.

High Priority: Sidewalk Infrastructure Improvements. City planning documents emphasize the need for expanded sidewalks and walkability, demonstrating a sustained commitment to improving pedestrian connectivity, recreational access, and quality of life.

Other Community Development and Housing Needs

High Priority: Neighborhood revitalization, building condition enforcement, and code-related improvements. City planning records have repeatedly linked neighborhood quality, nuisance enforcement, and housing conditions to Marshalltown's identified community development goals. The Community Development department implemented a property maintenance program in 2025.

Medium Priority: Capital improvements identified in the 2018-2028 Marshalltown Parks and Rec Strategic Master Plan as well as expansion of recreation activities for youth, senior, and special needs populations.

Medium Priority: Enhanced business opportunities to increase local workforce participation through improved transportation, education, and private investment. Marshalltown supports approximately 15,835 jobs; however, only about 54% of workers both live and work in the city, indicating a mismatch between employment opportunities and available housing.

Planned or Potential Activities to Address Housing and Community Needs

Planned or potential activities were developed in consultation with the City of Marshalltown City Council and city staff and are aligned with established strategic priorities identified in the *Reimagine Marshalltown Housing Market Analysis and Action Strategy (2026)*, *Comprehensive Plan 2030*, City Council meeting minutes, work sessions, capital improvement discussions, and resilience planning documents.

High Priority: Apply for funding under the Community Development Block Grant Disaster Relief Program to support the construction of new for-sale housing (up to 12 units) on infill lots, prioritizing those currently owned by the city, for low- to-moderate income households.

High Priority: Support infill development and housing variety. Marshalltown's Comprehensive Plan explicitly prioritizes reinvestment in existing neighborhoods rather than outward expansion. Pursue opportunities identified in the Housing Study and Comp Plan updates slated to be completed Summer 2026.

High Priority: Continue infrastructure and disaster recovery-related housing improvements. Following the 2018 tornado, Marshalltown has made substantial investments in rebuilding housing and infrastructure detailed in the *Downtown Master Plan* which was developed following the 2018 tornado and centers on reinvestment within the built environment. Continued need exists for repairs, resiliency upgrades, and reinvestment in impacted neighborhoods. Phase 2 of the CDBG-DR Tree Planting Project is underway which will replace an additional 150 trees which were lost in the 2020 Derecho.

High Priority: Prioritize Street, park/recreation, and public service improvements to make the best use of public dollars and provide amenities and opportunities to attract and retain residents.

- Continue Phase 2 of the Center/East Main Street Reconstruction project, including streets, sidewalks, lighting, landscaping, underground utility work, and the joint Marshalltown-Marshall County event plaza space.
- Continue hot-mix asphalt crack and joint sealing on 40 miles of roads throughout Marshalltown as part of continuing street preservation efforts.
- Continue rehabilitation work on the South Center Street Viaduct, a key transportation structure carrying traffic over rail lines and connecting neighborhoods to downtown and major corridors. The \$4.18 million project was funded through a combination of federal grants, state-administered transportation funding, and local bond and road use tax revenues.
- Complete construction of the Apgar Family Water Plaza, a public interactive community gathering space expected to be completed in Spring 2026 funded in part with a \$2 million Destination Iowa state grant, \$1.9 million in city fundings and nearly \$2 million in private donations.
- Continue planned Highway 14 Corridor Improvements.
- Complete construction of a 6-million-gallon reverse osmosis treatment plant and a 12-million-gallon lime softening treatment plant north of town which will increase the city's water capacity.

High Priority: Continue to update and review the community wide plans and continue outreach efforts in the *Marshalltown City News* to establish or expand services enhancing

public safety and ensuring services are accessible and affordable for low- to-moderate income households.

- Date and location assessment was prepared: City of Marshalltown City Council Meeting on [REDACTED]
- Number of local residents participating: [REDACTED]

DEVELOPER ASSURANCES: 2020 CDBG-DR New Housing Program

Name of Property Owner/Developer: **RALSTON Eco HOMES, LLC**

Address of Project Property: **Scattered Sites, Marshalltown, IA**

As rightful owner(s), developer(s), and/or responsible entity(s), we: (check boxes to confirm)

- Agree to the submission of the 2020 Derecho CDBG-DR Grant application for the benefit of the above-named property/project.
- Agree to all terms and conditions defined in the CDBG-DR Program Guidelines and Grant Application.
- Understand and agree to the federal compliance requirements of this grant including but not limited to: **environmental review** (no work on project site shall occur until after the environmental review record is complete and IEDA issues release of funds), **labor standards** and prevailing wages are required for all projects producing 8 or more housing units and/or public infrastructure, **Section 3** - all labor hours and income certification of all laborers must be recorded for any project receiving more than \$200,000 in CDBG-DR funds.
- Understand and agree to the term of affordability requirements of this program. All single family homes must be sold to buyers who qualify at or below 80% AMI, all rental projects must maintain at least 51% income qualified units for the term of affordability (15 years for single-family for-sale and 15 years for single-family rental units (1-4 units), 20 years for multi-family rental (5+ units)).
- Understand and agree to the baseline NGBS-silver building standards for disaster recovery housing as outlined in the NGBS Plan and Checklist.
- Understand that grant funds are made as a reimbursement and understand that you must complete the proposed scope of work for the project before receiving final reimbursement of grant funds.
- Agree to notify local grant recipient AND Iowa Economic Development Authority regarding changes in scope of work that may occur during construction that vary from the proposed plans submitted in the grant application. Substantial change in a project design may affect the amount of an award.
- Agree to abide by state and federal civil rights requirements which bars discrimination against any employee, applicant for employment, or any person participating in any sponsored program on the basis of race, creed, color, religion, sex, national origin, age, disability (mental and/or physical), political affiliation, sexual orientation, gender identity, or citizenship.
- Understand that IEDA reserves the right to take photographs of the project and use information relevant to the project in case studies, program marketing, etc.

By signing this Applicant Assurances document, we certify the information presented above, and in the application and attachments, to be true and correct to the best of the entity's knowledge.

Owner/Developer:
Ralston Eco Homes, LLC

Grant Recipient:
City of Marshalltown

Type/Print Name and Title

Type/Print Name and Title

Signature:

Signature

Jeff Ralston, President

Mike Ladehoff, Mayor

Date

Date

04-29-26

DUPLICATION OF BENEFITS CERTIFICATION
CDBG-DR NEW HOUSING DEVELOPMENT PROGRAM

The funding program to which you are applying (CDBG-DR) requires verification of additional financial assistance to comply with The Robert T. Stafford Disaster Relief and Emergency Assistance Act, (Stafford Act Section 312 42 U.S.C. 5121–5207) which prohibits federal agencies from providing financial assistance to any person, business concern, or other entity from receiving federal funds that are duplicative from any other program or any other source where the assistance amount exceeds the need for specific disaster recovery purpose.

Property Address: Scattered Sites, Marshalltown, IA

I/We, Jeff Ralston, President of Ralston Eco Homes, LLC, and Mike Ladehoff Mayor, City of Marshalltown, affirm the following:

Print Name

I/We make this Affidavit in connection with Community Development Block Grant Disaster Recovery (CDBG-DR) assistance through the Iowa Economic Development Authority (IEDA) and its local government partners.

I/We have received, or expect to receive, the funding listed on the funding Sources/Uses budget within the Application:

Assistance	Awarded/ Approved	Expected or Application Pending
Property Insurance		
FEMA		
National Flood Insurance Program		
SBA		
HUD HOME, ESG, and/or CDBG		
HUD (Other)		
Housing Trust Fund		
USDA-Rural Development		
LIHTC		
Federal Reserve Affordable Housing Program (AHP)		

Other (please name):		
Other (please name):		

Or

I/We received or expect to receive no additional recovery funds	(please check) ✓
---	---------------------

I/We agree to include all sources and uses of funds in the CDBG-DR Application and notify IEDA in writing of any changes to the information contained in this certification from the date of this Certification through the completion of the Project(s).

Title 18, Section 1001 of the U.S. Code states that a person is guilty of a felony for knowingly and willingly making false or fraudulent statements to any department of the United States Government.

I/We certify under penalty of perjury that all information provided as part of this application is true and correct to the best of my/our knowledge. I give my consent to the sponsoring organization considering this application to use the information provided herein for the purpose of CDBG-DR program consideration.

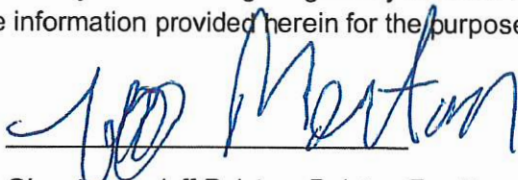

04-29-20

Signature – Jeff Ralston, Ralston Eco Homes, LLC Date

Signature – Mike Ladehoff City of Marshalltown Date

SUBROGATION AGREEMENT

This Subrogation and Assignment Agreement ("Agreement") is made and entered into on this 11th day of May, 2026, by and between the City of Marshalltown ("Applicant") and the Iowa Economic Development Authority ("Grantor").

In consideration of Applicant's financial situation or the commitment by Grantor to evaluate Applicant's application for the receipt of funds (collectively, the "Grant") under Iowa Economic Development Authority's CDBG Disaster Recovery New Housing Program (the "Program") administered by Grantor, Applicant hereby assigns to Grantor all of Applicant's future rights to reimbursement and all payments received from any grant, subsidized loan, or assistance under any housing assistance programs that are determined in the sole discretion of Iowa Economic Development Authority to be a duplication of benefits ("DOB") as provided in this Agreement.

The proceeds or payments referred to in the preceding paragraph, whether they are from a federal grant or any other source, and whether or not such amounts are a DOB, shall be referred to herein as "Proceeds," and any Proceeds that are a DOB shall be referred to herein as "DOB Proceeds." Upon receiving any Proceeds not listed on the Duplication of Benefits Certification, the Applicant agrees to immediately notify the Grantor of such additional amounts. The Grantor will determine in its sole discretion if such additional amounts constitute a DOB. If some or all of the Proceeds are determined to be a DOB, the portion that is a DOB shall be paid to the Grantor.

Applicant's assistance and cooperation shall include but shall not be limited to allowing suit to be brought in Applicant's name(s) and providing any additional documentation with respect to such consent, giving depositions, providing documents, producing record and other evidence, testifying at trial, and any other form of assistance and cooperation reasonably requested by the Grantor. Applicant further agrees to assist and cooperate in the attainment and collection of any DOB Proceeds that the Applicant would be entitled to under any applicable housing assistance program.

If requested by the Grantor, Applicant agrees to execute such further and additional documents and instruments as may be requested to further and better assign to the Grantor, to the extent of the Grant paid to Applicant under the Program, the Policies, any amounts received under the the Program that are DOB Proceeds and/or any rights thereunder, and to take, or cause to be taken, all actions and to do, or cause to be done, all things requested by the Grantor to consummate and make effective the purposes of this Agreement.

Applicant explicitly allows the Grantor to request of any organization with which the Applicant has applied for or is receiving *Proceeds*, any non-public or confidential information determined to be reasonably necessary by the Grantor to monitor/enforce its interest in the rights assigned to it under this Agreement and give Applicant's consent to such company to release said information to the Grantor.

Applicant represents that all statements and representations made by the Applicant regarding Proceeds received by the Applicant shall be true and correct as of the date of Closing.

NOTICE: Applicant executing this Agreement are hereby notified that intentionally or knowingly making a materially false or misleading written statement to obtain property or credits a violation of Title 18 United

States Code Section 1001 and, depending upon the amount of the Grant, is punishable by a fine, imprisonment for not more than five (5) years, or both, which may be ruled a felony, for any violation of such Section.

The Applicant executing this Agreement hereby represents that he\she has received, read, and understands this notice of penalties for making a materially false or misleading written statement to obtain the Grant.

In any proceeding to enforce this Agreement, the Grantor shall be entitled to recover all costs of enforcement, including actual attorney's fees.

APPLICANT

Signature: _____
Name: Mike Ladehoff, Mayor
Date: _____

CO-APPLICANT

Signature: 
Name: Jeff Ralston, Ralston Eco Homes
Date: 07-29-26

GRANTOR:

Iowa Economic Development Authority

Signature: _____
Name: _____
Title: _____
Date: _____

PROJECT ASSURANCES:

Name of Property Owner/Developer: Ralston Eco Homes, LLC
 Address of Project Property: Scattered Sites - Marshalltown, IA

As an applicant for an applicable Iowa Economic Development Authority assisted project, I have familiarized our project development team and contractors with the following local, state, and federal project guidelines/standards. (check boxes to confirm)

- ✓ (PROJECTS THAT INCLUDE A RESIDENTIAL COMPONENT ONLY): I agree to work with a third-party Home Energy Rating System (HERS) Rater to implement a HERS rating of residential elements of the project.
- ✓ I am aware of the NGBS-silver standard and our project is expected to follow the sustainable building practices outlined in the guidelines. As a part of this awareness process, I have reviewed and provided the NGBS-silver Best Practice Lists to the appropriate project contractors and/or sub-contractors:
 - Provided Heating, Ventilation, Air Conditioning System (HVAC) Contractor Best Practices List
 - Provided Plumbing Contractor Best Practices List
 - Provided Electrician Contractor Best Practices List
 - Provided General/Construction Contractor Best Practices List
 - (NEW CONSTRUCTION ONLY) Provided Site Designer/Civil Engineer Best Practices List
- I am aware of the Secretary of the Interior's [Standards for the Treatment of Historic Properties](#) and will put forth a good faith effort to follow best practices for the preservation and rehabilitation throughout the project.
- ✓ I agree to conform with the [Iowa Energy Code](#).
- ✓ I agree to conform with the [Americans with Disability Act](#).
- ✓ I agree to conform with all local building codes and regulations.
- ✓ I agree to conform with all local design guidelines and design review processes (if applicable).

By signing this Project Assurances document, we certify the above information to be true and confirm that the project team will incorporate the described practices into the project and grant application.

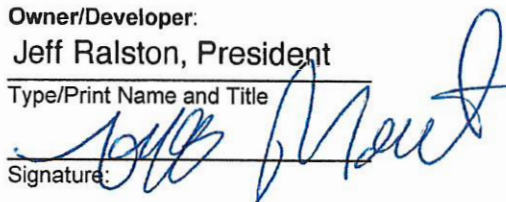
Owner/Developer:
Jeff Ralston, President
 Type/Print Name and Title
 Signature: 
 Date: 04-29-26

Local Government:
Mike Ladehoff, Mayor
 Type/Print Name and Title
 Signature: _____
 Date: _____

Applicant/Recipient Disclosure/Update Report

U.S. Department of Housing and Urban Development

OMB Number: 2501-0044
Expiration Date: 2/28/2027

Public Reporting Burden Statement: This collection of information is estimated to average 2 hours per response, including the time for reviewing instructions, searching existing data sources, gathering, and maintaining the data needed, and completing and reviewing the collection of the requested information. Comments regarding the accuracy of this burden estimate and any suggestions for reducing this burden can be sent to: U.S. Department of Housing and Urban Development, Office of the Chief Data Officer, R, 451 7th St SW, Room 8210, Washington, DC 20410-5000. Do not send completed HUD-2880 forms to this address. This agency may not conduct or sponsor, and a person is not required to respond to, a collection of information unless the collection displays a valid OMB control number. This agency is authorized to collect this information under Section 102 of the Department of Housing and Urban Development Reform Act of 1989. The information you provide will enable HUD to carry out its responsibilities under this Act and ensure greater accountability and integrity in the provision of certain types of assistance administered by HUD. This information is required to obtain the benefit sought in the grant program. Failure to provide any required information may delay the processing of your application and may result in sanctions and penalties including of the administrative and civil money penalties specified under 24 CFR §4.38. This information will not be held confidential and may be made available to the public in accordance with the Freedom of Information Act (5 U.S.C. §552). The information contained on the form is not retrieved by a personal identifier, therefore it does not meet the threshold for a Privacy Act Statement.

Applicant/Recipient Information * UEI Number: PL3MIMD6SM7 * Report Type: INITIAL

1. Applicant/Recipient Name, Address, and Phone (include area code)

* Applicant Name: City of Marshalltown

* Street 1: 24 North Center Street

Street 2:

City: Marshalltown State Abbreviation: IA * Zip Code: 50158

County: Marshall

* Country: USA- United States

* Phone: 641-754-5701

2. Employer ID Number (do not include individual social security numbers): 42-6004934

3. HUD Program Name: Community Development Block Grant Disaster Recovery

4. Amount of HUD Assistance Requested/Received: \$ 1,981,407

5. State the name and location (street address, City and State) of the project or activity scattered sites

Project Name: Marshalltown CDBG-DR New Housing Production - For Sale Project (scattered sites in Marshalltown, IA)

* Street 1: scattered sites

Street 2:

City: Marshalltown State Abbreviation: IA * Zip Code: 50158

County: Marshall

* Country: USA: UNITED STATES

Part I Threshold Determinations

<p>1. Are you applying for assistance for a specific project or activity? These terms do not include formula grants, such as public housing operating subsidy or CDBG block grants. For further information see 24 CFR Sec. §4.3.</p> <p><input checked="" type="checkbox"/> Yes <input type="checkbox"/> No</p>	<p>2. Have you received or do you expect to receive assistance within the jurisdiction of the Department (HUD), involving the project or activity in this application, in excess of \$200,000 during this fiscal year (Oct. 1-Sep. 30)? For further information, see 24 CFR §4.9.</p> <p><input checked="" type="checkbox"/> Yes <input type="checkbox"/> No</p>
---	---

If you answered "No" to either question 1 or 2, **Stop!** You do not need to complete the remainder of this form. However, you must sign the certification at the end of the report.

Part II Other Government Assistance Provided or Requested/Expected Sources and Use of Funds. Such assistance includes, but is not limited to, any grant, loan, subsidy, guarantee, insurance, payment, credit, or tax benefit.

Department/State/Local Agency Name			Department/State/Local Agency Name		
* Government Agency Name:			* Government Agency Name:		
Government Agency Address:			Government Agency Address:		
* Street 1:			* Street 1:		
Street 2:			Street 2:		
City:	State Abbreviation:	* Zip Code:	City:	State Abbreviation:	* Zip Code:
Country:			Country:		
Country:			Country:		
* Type of Assistance:			* Type of Assistance:		
* Amount Requested/Provided: \$			* Amount Requested/Provided: \$		
* Expected Uses of the Funds:			* Expected Uses of the Funds:		

Note: For Part 1, use additional pages if necessary. Add Attachment:

Part III Interested Parties. You must disclose:

- All developers, contractors, or consultants involved in the application for assistance or in the planning, development, or implementation of the project or activity.

* Alphabetical list of all persons with a reportable financial interest in the project or activity (for individuals, give the last name first)	* Unique Entity ID	* Type of Participation in Project/Activity	* Financial Interest in Project/Activity (\$ and %)			
Ratston Eco Homes, LLC	NV6JBNX80CB8	Developer	\$	1,587,407	80.12	%
			\$			%
			\$			%

- Any other person who has a financial interest in the project or activity for which the assistance is sought that exceeds \$50,000 or 10 percent of the assistance (whichever is lower).

* Alphabetical list of all persons with a reportable financial interest in the project or activity (for individuals, give the last name first)	* City of Residence	* Type of Participation in Project/Activity	* Financial Interest in Project/Activity (\$ and %)			
			\$			%
			\$			%
			\$			%

Note: For Part 2, use additional pages if necessary. Add Attachment:

Certification:

I/We, the undersigned, certify under penalty of perjury that the information provided above is true, accurate, and correct. Warning: Anyone who knowingly submits a false claim or makes a false statement is subject to criminal and/or civil penalties, including confinement for up to 5 years, fines, and civil and administrative penalties. (18 U.S.C. §§ 287, 1001, 1010, 1012, 1014; 31 U.S.C. §3729, 3802; 24 CFR §28.10(b)(1)(iii)).

* Signature:

* Date: (mm/dd/yyyy): 05/11/2026

Instructions for the HUD 424-B Assurances and Certifications

As part of your application for HUD funding, you, as the official authorized to sign on behalf of your organization or as an Individual, must provide the following assurances and certifications. The Responsible Civil Rights Official has specified this form for use for purposes of general compliance with 24 CFR §§ 1.5, 3.115, 8.50, and 146.25, as applicable. The Responsible Civil Rights Official may require specific civil rights assurances to be furnished consistent with those authorities and will specify the form on which such assurances must be made. A failure to furnish or comply with the civil rights assurances contained in this form may result in the procedures to effect compliance at 24 CFR §§ 1.8, 3.115, 8.57, or 146.39.

By submitting this form, you are stating that all assertions made in this form are true, accurate, and correct.

As the duly representative of the applicant, I certify that the applicant: [Insert below the Name and title of the Authorized Representative, name of Organization and the date of signature]:

*Authorized Representative Name:

Joel Groer

*Title: Mayor

*Applicant/Recipient Organization:

City of Marshalltown

1. Has the legal authority to apply for Federal assistance, has the institutional, managerial and financial capability (including funds to pay the non-Federal share of program costs) to plan, manage and complete the program as described in the application and the governing body has duly authorized the submission of the application, including these assurances and certifications, and authorized me as the official representative of the application to act in connection with the application and to provide any additional information as may be required.

2. Will administer the grant in compliance with Title VI of the Civil Rights Act of 1964 (42 U.S.C. 2000(d)) and implementing regulations (24 CFR part 1), which provide that no person in the United States shall, on the grounds of race, color or national origin, be excluded from participation in, be denied the benefits of, or otherwise be subject to discrimination under any program or activity that receives Federal financial assistance OR if the applicant is a Federally recognized Indian tribe or its tribally designated housing entity, is subject to the Indian Civil Rights Act (25 U.S.C. 1301-1303).

3. Will administer the grant in compliance with Section 504 of the Rehabilitation Act of 1973 (29 U.S.C. 794), as amended, and implementing regulations at 24 CFR part 8, the American Disabilities Act (42 U.S.C. §§ 12101 et seq.), and implementing regulations at 28 CFR part 35 or 36, as applicable, and the Age Discrimination Act of 1975 (42 U.S.C. 6101-07) as amended, and implementing regulations at 24 CFR part 146 which together provide that no person in the United States shall, on the grounds of disability or age, be excluded from participation in, be denied the benefits of, or otherwise be subjected to discrimination under any program or activity that receives Federal financial assistance; except if the grant program authorizes or limits participation to designated populations, then the applicant will comply with the nondiscrimination requirements within the designated population.

4. Will comply with the Fair Housing Act (42 U.S.C. 3601-19), as amended, and the implementing regulations at 24 CFR part 100, which prohibit discrimination in housing on the basis of race, color, religion, sex, disability, familial status, or national origin and will affirmatively further fair housing; except an applicant which is an Indian tribe or its instrumentality which is excluded by statute from coverage does not make this certification; and further except if the grant program authorizes or limits participation to designated populations, then the applicant

will comply with the nondiscrimination requirements within the designated population.

5. Will comply with all applicable Federal nondiscrimination requirements, including those listed at 24 CFR §§ 5.105(a) and 5.106 as applicable.

6. Will not use Federal funding to promote diversity, equity, and inclusion (DEI) mandates, policies, programs, or activities that violate any applicable Federal anti-discrimination laws.

7. Will comply with the acquisition and relocation requirements of the Uniform Relocation Assistance and Real Property Acquisition Policies Act of 1970, as amended (42 U.S.C. 4601) and implementing regulations at 49 CFR part 24 and, as applicable, Section 104(d) of the Housing and Community Development Act of 1974 (42 U.S.C. 5304(d)) and implementing regulations at 24 CFR part 42, subpart A.

8. Will comply with the environmental requirements of the National Environmental Policy Act (42 U.S.C. 4321 et seq.) and related Federal authorities prior to the commitment or expenditure of funds for property.

9. That no Federal appropriated funds have been paid, or will be paid, by or on behalf of the applicant, to any person for influencing or attempting to influence an officer or employee of any agency, a Member of Congress, and officer or employee of Congress, or an employee of a Member of Congress, in connection with the awarding of this Federal grant or its extension, renewal, amendment or modification. If funds other than Federal appropriated funds have or will be paid for influencing or attempting to influence the persons listed above, I shall complete and submit Standard Form-LLL, Disclosure Form to Report Lobbying. I certify that I shall require all subawards at all tiers (including sub-grants and contracts) to similarly certify and disclose accordingly. Federally recognized Indian Tribes and tribally designated housing entities (TDHEs) established by Federally-recognized Indian tribes as a result of the exercise of the tribe's sovereign power are excluded from coverage by the Byrd Amendment, but State-recognized Indian tribes and TDHEs established under State law are not excluded from the statute's coverage.

I/We, the undersigned, certify under penalty of perjury that the information provided above is true, accurate, and correct. WARNING: Anyone who knowingly submits a false claim or makes a false statement is subject to criminal and/or civil penalties, including confinement for up to 5 years, fines, and civil and administrative penalties. (18 U.S.C. §§287, 1001, 1010, 1012, 1014; 31 U.S.C. §3729, 3802; 24 CFR §28.10(b)(1)(iii)).

* Signature:

* Date: (mm/dd/yyyy): 05/11/26



Selecting a home improvement contractor following a disaster is not an easy task. Our office has put together this checklist to assist you in reducing your risk of losing money to a disreputable or even overworked contractor. The foundation to a good home repair is a good contractor. The cheapest price isn't always the best choice so it's important to find a reputable contractor.

IS THE CONTRACTOR FROM IOWA OR A BORDERING STATE?

Don't fall for the contractor who shows up in an unmarked vehicle or has out-of-state license plates and hands you a business card. An old trick used by storm chasing contractors is to blow into town after a disaster, get business cards printed in one hour, and use a temporary address (sometimes it is a local hotel or a post office box) so it appears they are from Iowa when they are not! If you need follow-up or warranty work from an out-of-state contractor, you may not be able to get in touch with them again. Ask people you know and trust who have used the contractor for their projects and whether the work has been started or completed to their satisfaction.

WATCH OUT FOR INSURANCE SCAMS!

If you're filing an insurance claim to cover the costs of storm damage, negotiate the details with your insurance company directly and not through a contractor. You, as the homeowner, need to be involved in the entire process from claim, to project completion, to payment. **DO NOT PAY THE CONTRACTOR UNTIL THE JOB IS COMPLETED TO YOUR SATISFACTION.** Reputable contractors have established lines of credit that allow them to purchase and pay for materials once the job is completed. Once you pay an out-of-state contractor, they may lose the incentive to return to do the job. It becomes easier and more profitable to move on to the next job and get paid before moving on to the next town. **It is extremely difficult to get your money back from any contractor!**

DOES THIS CONTRACTOR HAVE A HISTORY OF BAD BUSINESS PRACTICES?

Email the Iowa Attorney General at consumer@ag.iowa.gov or call 515-281-5926 and check the Better Business Bureau complaint database at www.bbb.org to see whether the contractor you're considering has had complaints in the past. To see if a contractor has been sued or has filed a lawsuit, search Iowa Courts Online (see attachment).

IS THE CONTRACTOR REGISTERED?

Every contractor who does business in Iowa is required to register with Iowa Workforce Development (IWD) and out-of-state contractors are required to post a bond. Although a contractor's registration and bonding doesn't guarantee the quality of work or payment of damages if a dispute arises with the contractor, it may help you determine the professionalism and longevity of a contractor. Verify a contractor's registration and bonding at <https://contractor.iowa.gov/IowaIWD/CREG/common/index.jsp> or 515-242-5871 to search for any contractor you're considering and ask the contractor for a copy of their liability insurance certificate.

DOES THE CONTRACTOR HAVE NO RECORD AT ALL?

If there is NO information about the contractor when you research the Iowa Attorney General, Better Business, Bureau, Iowa Courts Online, and Iowa Workforce Development, that is a RED

FLAG because an established contractor will be registered with Iowa Workforce Development and have a verifiable history with the Better Business Bureau.

- GET AT LEAST ONE OTHER ESTIMATE SO YOU KNOW THE PRICE IS FAIR.
- GET ALL OF THE CONTRACT DETAILS IN WRITING!
 - 1) details the work to be done,
 - 2) the brand and specifications of the materials to be used,
 - 3) the price,
 - 4) who is responsible for obtaining building permits and scheduling inspections,
 - 5) language stating that all change orders must be in writing,
 - 6) who is responsible for cleanup,
 - 7) start date, and completion date (as well as the remedies if the contractor fails to meet them, such as the contract could be nullified if the contractor doesn't start on time, that frees you to contract with someone else without paying a penalty for canceling the contract.)
- READ THE CONTRACT (front and back) BEFORE YOU SIGN IT.
- YOU HAVE THREE BUSINESS DAYS TO CANCEL THE CONTRACT.

If you sign a contract somewhere other than the contractor's regular place of business, such as at your home, you have three business days to cancel the contract without penalty. If you exercise your right to cancel, you must send a cancellation notice by certified mail and it is best to request a return receipt to prove the date you cancelled.
- DO NOT PAY THE CONTRACTOR UNTIL THE JOB IS COMPLETED TO YOUR SATISFACTION. Reputable contractors have established lines of credit that allow them to purchase materials and pay once the job is completed. Once a disputable contractor is paid, they lose all incentive to return to do the job. It becomes easier and more profitable to move on to the next job and get paid before moving out-of-town. **It is extremely difficult to get your money back from a disputable contractor!**
- INSIST ON A MECHANIC'S LIEN WAIVER WHEN YOU MAKE YOUR FINAL PAYMENT (see attached) as the waiver will protect the homeowner in case the contractor fails to pay others for materials or labor. The Iowa Secretary of State will notify you by mail if a contractor has placed a mechanic's lien on your home. A mechanic's lien simply secures an interest in your property on behalf of the contractor for 2 years and 90 days. It is much easier to resolve a potential dispute by asking the contractor to sign the waiver as you make your final payment.
- THINKING ABOUT FINANCING?

Compare your financing options. It's usually safer and a better deal to obtain financing through your local bank or credit union, rather than a contractor. Do some loan shopping and compare loan terms. Don't let anyone pressure you into signing a loan document and never deed your property to anyone.

We hope you find this information helpful. If you have questions or need further assistance, please send an email to Susan.Kerr@AG.Iowa.gov or call 515-281-6414 to leave me a message.

Thank you for reaching out to Attorney General Tom Miller's office.

Iowa Courts Online

Since 1998, the Iowa Judicial Branch has maintained a statewide electronic docket. The docket is a summary of basic case information such as case types, case numbers, an index of filings and orders for each case, names of litigants and attorneys, criminal charges, payments of fines, fees, and child support, judgments and liens. The judicial branch does not have complete documents in electronic format.

[Iowa Courts Online](#) has information from civil, criminal, probate, and traffic courts. This may be helpful when choosing a home improvement contractor to see if the company or individual has been sued in civil court. A search can be made by the company name or the owner's name.

Civil cases typically fall into three major categories:

1. Family law (divorce and child support and custody);
2. Tort law (personal injury, property damage, or product liability);
3. Contract law (written and oral agreements).

Searches for home improvement contracts will generally be categorized as contract law. Small claims court may be used for money claims up to \$6,500. Small claims court procedures are designed for people to pursue their claims without an attorney's help, although representation by an attorney in small claims court is also allowed. District court is designed for claims over \$6,500 and generally requires representation by a private attorney.

Helpful Links

[Iowa Courts Online Help Guide](#)

[Guide to Iowa's Court System](#)

RELEASE AND WAIVER OF LIEN

STATE OF IOWA, COUNTY OF _____

_____ OF _____
(Contractor or Agent Name) (Company Name)

That said company or person, performed work, labor, services and/or furnished material
in the repair or improvement of realty at _____
(Contract site address & Property owner's phone number)

(Description of work done)

That said company, or person, has been paid \$ _____ pursuant to the terms and
conditions of its contract with _____ including labor,
(Property owner's name)

material and equipment furnished by it through _____, 20 ____ the receipt and

sufficiency of which is hereby acknowledged. The undersigned so hereby waive all liens and claims
which said company, or person, may have against the above property through the aforesaid date, and
further, the undersigned represents that no other person or party has any right to a lien on the above
property on account of any work performed or materials furnished to said company, or person, under its
contract. This payment represents FULL payment of the contract.

Company _____

Federal ID or SSN # _____

Address _____

City _____

SIGNATURE _____

Title _____

Phone _____

Mechanic's Notice and Lien Registry (MNLR)

This form needs to be signed by the general contractor before you make your final payment!

You may find more information about a mechanic's lien and filing instructions at the Iowa Secretary of
State Mechanic's Notice and Lien Registry (MNLR) website at:
<https://sos.iowa.gov/mnlr/account/signin.aspx>, or call (888) 767-8683.



**MARSHALLTOWN
MORE THAN EVER**

**Mike Ladehoff, Mayor
Carol Webb, City Administrator
24 North Center Street
Marshalltown, IA 50158
PH 641.754.5701 • FX 641.754.5717**

To: Mayor and City Council
From: Heather Thomas, Public Works Director
Meeting Date: May 11, 2026
Re: Ordinance 15119 to Amend the Code of Ordinances, City of Marshalltown, Iowa by Amending Chapter 53: Storm Water by Amending Section 53.006 Rate Structure and Storm Water Rate - Third Reading

Strategic Plan Objective:

Plan and fund improvements to the City's infrastructure and buildings; Review programs and services

Recommended:

Pass ordinance modifying the storm water monthly utility rate to \$4.60 / ERU with an annual automatic 1% increase.

Budget Impact:

Storm Water operates as an Enterprise Fund. To account for a change in Storm Water Rate increase from \$4.20/ERU to \$4.60/ERU, the anticipated revenue (account 740.8065.4430) would increase from \$1,344,856 to \$1,472,900 in FY27.

Description/Background:

During budget discussion, city staff brought forward information related to the storm water enterprise fund requesting an increase from \$4.20/ERU to \$4.50/ERU. City council directed staff to bring back an Ordinance to increase the rate to \$4.60/ERU and add a 1% annual increase, which city staff are supportive on.

Background from 03/23/26 City Council Meeting - STORM WATER

Our storm water division operates primarily out of **Fund 740** for standard operating / debt service payment fund.

As we talk about storm sewer, it covers many areas. So, where do these fees go & what are they used for?

1. Staff & equipment to maintain storm sewer, box culverts, city owned retention/detention basins, and infrastructure data management.

1. ~62 Miles of Storm Sewer Pipe from 6-72"
2. ~3,700 Intakes/Structures
2. Staff & equipment to maintain storm water pump stations (Riverview Park & 18th Ave) & non-fixed-stations pumps.
3. Staff & equipment to maintain our levee system.
4. Partially funds staff in engineering that permit or design storm water infrastructure. Enforce ordinances related to storm water runoff.
5. Hire Marshalltown Water Works to do utility billing.
6. Pays 10% of the City Administrator wages and benefits.
7. Pays 5% of HR Director's wages and benefits.
8. Pays \$19,100 annually to assist with Finance Department's staff, services and software.
9. Manage Local Floodplain Permits.
10. State of Iowa Requirement – Manage city's MS4 Permit, annual report, annual inspections of city infrastructure, and quarterly inspections of private construction projects
11. Capital Storm Infrastructure Projects.
12. Debt Service on Past Storm Water Projects (2016 & 2020) ~\$555k

We also have storm water projects or aspect of capital projects that may be funded through straight GO Bonds that are not pulled out of storm water utility fund.

Below is a summary of how the attached budget comparison reports impact fund balance for FY26 and FY27.

FUND 740	Department Budget Iteration #1
FY26 Starting Fund Balance	\$ 2,837,093.96
FY26 Net Revenue/Expenses	- \$ 600,908.00
Projected FY26 End/FY27 Start Balance	\$ 2,236,184.96
Anticipated FY 27 Storm Sewer Charge Revenue (No Increase)	\$ 1,344,856.00
Anticipated FY 27 Net Operating (excluding sewer charge rev & all capital expenditures)	- \$ 732,972.00
Requested FY 27 Capital Expenses	- \$532,278.00
Anticipated FY 27 Debt Service	- \$ 556,910.00
Anticipated FY 27 Payment (28E)	- \$ 131,180.00
<i>Subtotal FY27 Net Revenue/Expenses</i>	<i>- \$ 608,484.00</i>
Projected Ending FY27 Fund Balance	\$ 1,627,700.96

In preparing the budget, we are operating in a budget shortfall. Several items noted as large contributions:

- Starting in FY26, council amended the city ordinance to remove storm water fees on certain public and recreational properties. Several other properties had rate credits reviewed and we also only collect what is paid to MWW. Revenue projections between FY25 and FY26 dropped \$110,000.
- In FY26, the city entered into a 28E agreement with MCSO related to the Franklin Field Storm Sewer, at a cost of \$131,180.
- Remainder of Storm Water Bond Fund Projects from last debt issuance (closed account 741 and swapped into 740 ~ \$400,000 from 4th/Meadow). This artificially increased fund balance in 740 by about \$400,000 until that work is completed.
- Capital Projects included in budget requests utilizing non-bond, storm water revenue include
 1. FY26 Capital Expenses: \$253,111
 2. FY27 Capital Expenses: \$532,278
 3. The larger amounts of these Capital Projects and Purchases include:
 - Lift Station Repairs, Maintenance, Pump Costs, \$156,000 (FY26) & \$85,000 (FY27)
 - Portion of Planned FY27 TV Transporter Truck, \$40,000
 - Portion of Tractor (mowing levee system), \$60,000
 - State St Storm Outlet (N 1st Ave to Lincoln) - \$170,000 (had been bond request)
 - Subdrain Retrofit – Peking Intakes - \$61,179
 - Annual Emergency Repair Budget - \$50,000

While several of these capital purchases/projects have been planned and intentional to spending down

City staff have reviewed and made the following **recommendations**:

Reduce Expenses:

1. Delay a portion of Pump Station work until bond project contingency can be released. (potential to reduce capital purchases/expenditures ~ \$100,000 between FY26 & FY27)
2. Delay State St Storm Outlet (N 1st Ave to Lincoln) or utilize GO Bond. Finance indicates a potential to fund with 740 until a GO Bond is issued and then reimburse Fund 740 (Estimated \$170,000 in FY27)
3. Fund the TV Transporter Truck from Sanitary Sewer (Shifts \$40,000 in FY27 from 740 to 610)
4. Leave Vacant Storm Water Coordinator Position upon Oct' 27 Retirement (~\$45,000 in FY27)

Increase Revenue:

- Several discussions regarding storm water rates have been had with a rate review indicating

recommended 10% and 40% increases in mid-2021. Reluctance to raise rates, resulted in holding steady and during the winter 2023/2024 budget discussion, doing a 5% increase effective July 1, 2024 (FY25).

- During winter 2024/2025 budget discussions, council voted in an Ordinance change removing certain properties from paying storm water fees effective July 1, 2025 for FY26, which contributed to a loss in revenue during FY26 that was greater than the rate raises implemented in FY25. A review of the historic utility rate is shown below.
- A \$0.30 rate increase represents an estimated \$96,000 in increased revenue.

Depending on council input, if we were to capture Expenditure Reductions in Tyler for #2 and #3 and capture a \$0.30 rate increase, that would result in a projected Fund 740 balance at the end of FY27 of \$1,933,700.96.

Many projects can overlap between allowable funding sources related to storm water. Some examples include:

- 4th & Meadow Lane project installed new storm sewer and resurfaced the adjoining streets that were impacted; this was all funded through Revenue Bond.
- Storm sewer installed as part of the State St reconstruction project was funded through GO Bond.
- Box Culvert work associated with a culvert on State Street and engineering for the Center St Bridge over Linn Creek is planned to be funded through Road Use Tax.
- Storm Sewer work associated with the 7th Ave Extension project was funded through Fund 740, storm water rates.

Because of the potential for funding source variability between storm and road projects, we would like to propose a larger discussion about long term Funds and objectives with Fund 340, especially as it relates to potential road work and the levee system. With additional information coming later this summer with the Pavement Management Study, we would propose these discussions to occur concurrently with those efforts.

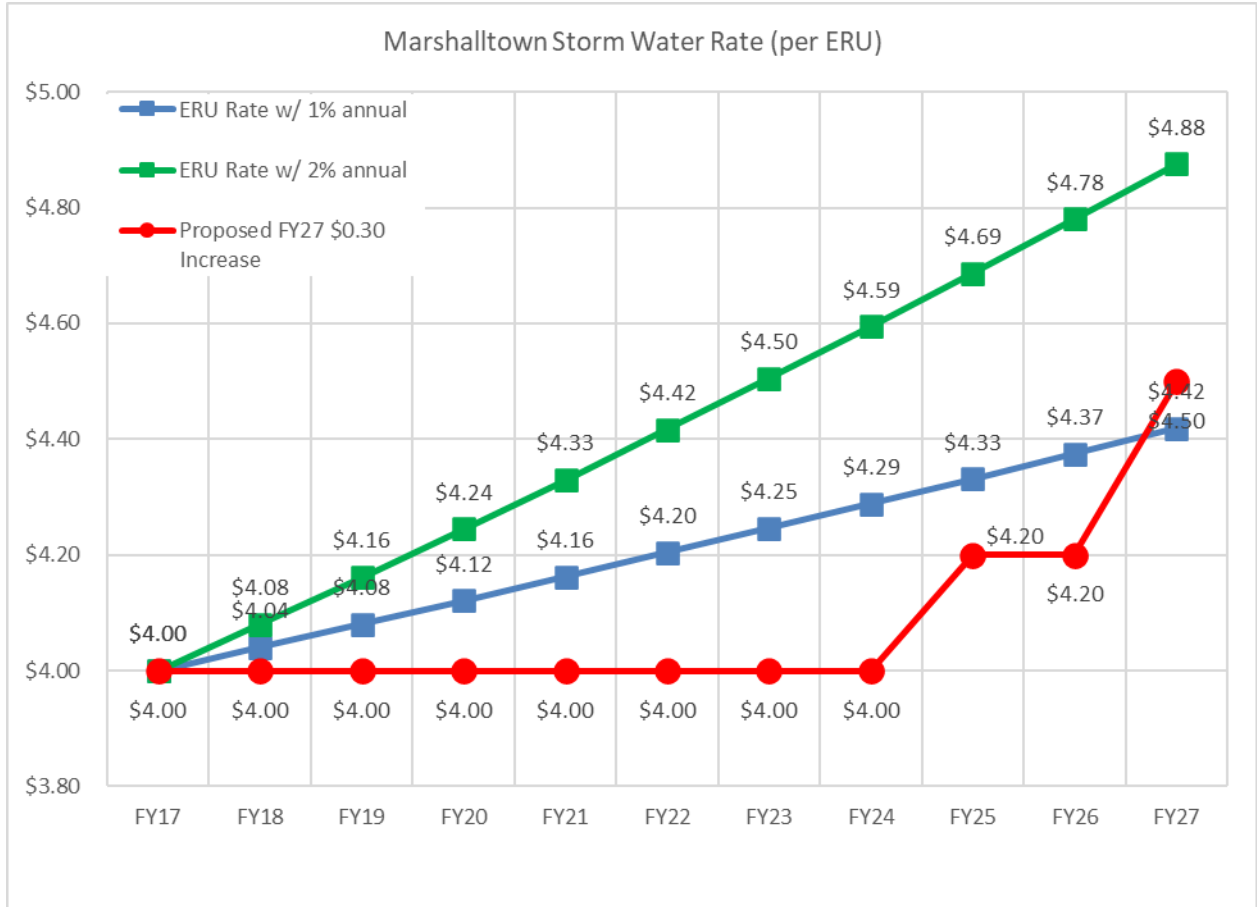

Attachments:

1. Amend CH 53 Storm Water Rates

ORDINANCE 15119

ORDINANCE TO AMEND THE CODE OF ORDINANCES, CITY OF MARSHALLTOWN, IOWA BY AMENDING CHAPTER 53: STORM WATER BY AMENDING SECTION 53.006 RATE STRUCTURE AND STORM WATER RATE

BE IT ORDAINED BY THE COUNCIL OF THE CITY OF MARSHALLTOWN, IOWA:

Section 1. The Code of Ordinances, City of Marshalltown Section 53.006 (E) is hereby amended with the following:

(E) Commencing on July 1, 2026, and continuing thereafter, the monthly unit rate shall be \$4.60 per equivalent residential unit (ERU).

Section 2. The Code of Ordinances, City of Marshalltown Section 53.006 (F and G) is hereby added:

(F) The monthly utility rate shall be automatically increased, annually, by 1% above the rate charged the previous year, rounded to the nearest cent, without a vote or further action of the City Council. The automatic annual rate increase shall be effective for the first time on July 1, 2027 and increase each year thereafter on July 1.

(G) Nothing in this chapter shall prevent the City Council from increasing the monthly unit rate by a an amount or percentage greater than 1% should the City Council determine that a greater amount or percentage is needed to meet the needs of the city and its citizens.

Section 3. The Code of Ordinances of the City of Marshalltown is hereby amended and all ordinances or parts of ordinances in conflict with the provisions of this ordinance are hereby repealed.

Section 4. If any section, provision, or part of this ordinance shall be adjudged invalid or unconstitutional, such adjudication shall not affect the validity of the ordinance as a whole or any section, provision, or part thereof not adjudged invalid or unconstitutional.

Section 5. This ordinance shall be in effect after its final passage, approval, and publication as provided by law.

Passed this _____ day of _____, 2026, and signed this _____ day of _____, 2026.

CITY OF MARSHALLTOWN, IOWA

Mike Ladehoff, Mayor

ATTEST:

Alicia Hunter, CMC, City Clerk

I, Alicia Hunter, City Clerk of the City of Marshalltown, Iowa, do hereby certify that the foregoing ORDINANCE was passed and approved by the City Council of the City of Marshalltown, Iowa, on the ____ day of _____, 2026, and was published in the Marshalltown Times-Republican, a newspaper of general circulation in the City of Marshalltown, Iowa, on the ____ day of _____, 2026.

Alicia Hunter, City Clerk



**MARSHALLTOWN
MORE THAN EVER**

**Mike Ladehoff, Mayor
Carol Webb, City Administrator
24 North Center Street
Marshalltown, IA 50158
PH 641.754.5701 • FX 641.754.5717**

To: Mayor and City Council
From: Carol Webb, City Administrator
Meeting Date: May 11, 2026
Re: Temporary Ordinance 15120 of the City of Marshalltown, Iowa, Enacted to Assist City Officials and the RAGBRAI Committee to Address Public Health and Safety Issues Created by the Des Moines Register's Annual Great Bicycle Ride Across Iowa (RAGBRAI) When it Arrives in Marshalltown on July 22, 2026 - First Reading

Strategic Plan Objective:

N/A

Recommended:

Staff recommends that City Council approve the first reading of the RAGBRAI Temporary Ordinance.

Staff further requests that Council consider whether to waive the second reading by motion approved by three-fourths of all Councilmembers. Staff anticipates requesting waiver of the third reading in order to allow the ordinance to become effective in a timely manner for RAGBRAI planning and implementation.

Budget Impact:

The ordinance establishes vendor permit fees, electrical access fees, late application fees, shower vendor fees, and refundable site clean-up deposits to help offset event-related administrative, logistical, sanitation, and site management costs associated with RAGBRAI.

Because the event is being coordinated in partnership with the Marshalltown RAGBRAI Committee and the Marshalltown Area Chamber of Commerce, many event-specific costs and revenues will be managed through the local RAGBRAI planning structure rather than through the City's regular operating budget. However, the City will incur staff time and may incur costs related to public safety, traffic control, public works support, parks, sanitation coordination, and use of City-owned property and rights-of-way.

Description/Background:

The City of Marshalltown will serve as an overnight host community for RAGBRAI on July 22,

2026. The event will bring a significant number of bicyclists, support vehicles, vendors, visitors, and event-related activities into the community for a short period of time. Because of the size and temporary nature of the event, certain local regulations need to be modified or supplemented to allow for safe, coordinated, and efficient event operations.

The attached ordinance is a temporary RAGBRAI ordinance. Because it is limited in duration and applies only to the 2026 RAGBRAI event, it would not be codified as a permanent part of the Marshalltown Municipal Code. The ordinance would be effective upon passage and publication and would remain in effect through noon on July 23, 2026.

Summary of Ordinance

The proposed ordinance is intended to assist City officials, the Marshalltown RAGBRAI Committee, and the Marshalltown Area Chamber of Commerce in managing public health, safety, vendor activity, right-of-way use, parking, park use, camping, and related event operations.

Key provisions include:

1. Requiring vendors selling or providing food or goods outside their regular business location to obtain a RAGBRAI vendor permit.
2. Establishing vendor permit fees, electrical access fees, shower vendor fees, late fees, and a refundable clean-up deposit.
3. Giving the RAGBRAI Committee authority to assign vendor locations and manage designated event areas, City rights-of-way, City-owned downtown properties, and City parking lots.
4. Requiring beverages sold for outdoor consumption to be served in non-glass containers.
5. Temporarily waiving the City’s open container restrictions, while keeping state alcohol laws and the prohibition on open containers in motor vehicles in effect.
6. Preventing existing alcohol license holders from expanding their licensed premises or service area for the event.
7. Temporarily suspending certain parking, bicycle, park-hours, camping, and golf car restrictions to accommodate event operations.
8. Authorizing temporary street closures, barricades, and traffic-control measures.
9. Allowing enforcement against unauthorized vending, including nuisance abatement, municipal infraction penalties, and additional fees.

Purpose of the Ordinance

The purpose of the ordinance is not to create permanent policy changes, but rather to provide a temporary legal and operational framework for a large-scale special event. RAGBRAI creates unique demands on City facilities, streets, parks, public safety personnel, sanitation, vendor management, and downtown activity. The ordinance helps ensure that event operations are

coordinated through the RAGBRAI Committee, while also giving the City the tools needed to protect public safety, manage public property, and respond quickly to event-related issues.

Consideration of Readings

Ordinances normally require three readings unless Council votes to suspend the rules and waive one or more readings. Staff anticipates asking Council to waive the third reading at the time of final consideration so the ordinance can be adopted in time to support event planning and vendor coordination.

Council may also choose to waive the second reading at tonight’s meeting. This would require a motion and approval by three-fourths of all Councilmembers. If Council waives the second reading tonight, the ordinance could proceed more quickly to final consideration. If Council does not waive the second reading, the ordinance would return for the second reading at the next regular Council meeting.

Attachments:

- 1. Marshalltown RAGBRAI Ordinance Final

ORDINANCE 15120

AN ORDINANCE OF THE CITY OF MARSHALLTOWN, IOWA, ENACTED TO ASSIST CITY OFFICIALS AND THE RAGBRAI COMMITTEE TO ADDRESS PUBLIC HEALTH AND SAFETY ISSUES CREATED BY THE DES MOINES REGISTER'S ANNUAL GREAT BICYCLE RIDE ACROSS IOWA (RAGBRAI) WHEN IT ARRIVES IN MARSHALLTOWN ON JULY 22, 2026

WHEREAS, the City of Marshalltown was selected as an overnight stop for RAGBRAI on July 22, 2026.

WHEREAS, the City Council finds the following regulations to be in the best interest of the City and the general public.

NOW THEREFORE BE IT ORDAINED BY THE COUNCIL OF THE CITY OF MARSHALLTOWN, IOWA:

That the Municipal Code of the City of Marshalltown, Iowa, be amended by this Ordinance designated "RAGBRAI ORDINANCE," which because of its temporary nature shall not be printed as part of the permanent Code of Ordinances. The RAGBRAI Ordinance is as follows:

Section 1. Definitions.

As used herein, "food" shall include food products of all kinds, including food packaged for consumption off premises as well as meals prepared for consumption either on or off premises. Food shall also include beverages of every kind, including both alcoholic and nonalcoholic, except for water provided without cost to the consumer.

As used herein, "person" shall include any individual person, club, group, organization, partnership, corporation, or entity of any kind.

The RAGBRAI Committee for purposes herein shall be defined as the Marshalltown Area Chamber of Commerce and its designated event planning committee, serving as the primary coordinating body for RAGBRAI in Marshalltown.

Section 2. Commercial Vendor Booth - Permit Required.

No person shall provide or sell food or goods to the public in Marshalltown, Iowa, on July 22, 2026, at a location other than their regularly established place of business unless said person shall first obtain a Commercial Vendor Booth Permit from the Marshalltown RAGBRAI Committee through the Marshalltown Area Chamber of Commerce office located at 34 West Main Street, Marshalltown, Iowa. The RAGBRAI Committee shall review all permits.

For purposes of this Section, any peddler/transient merchant permit previously issued by the City of Marshalltown shall not exempt a person or entity from the requirement to obtain a vendor permit pursuant to this Ordinance. Any person operating within the designated expo area must obtain a permit. This includes businesses in the expo area that wish to expand operation to the right-of-way pursuant to Section 14.

Section 3. Vendor Permit Fees.

The following fees shall apply to vendor booth permits issued pursuant to this Ordinance:

- a. Non-Profit Vendor Booth Permit: \$150.00 (this includes for-profit vendors that are not selling product but just promoting their business)
- b. For-Profit Commercial Vendor Booth Permit (non-local): \$500.00
- c. Local Vendor Booth Permit (business address within Marshalltown city limits): \$300.00
- d. Electrical Access Fee (subject to availability): \$150.00 per connection
- e. Refundable Site Clean-Up Deposit: \$100.00
- f. Shower Vendor Permit: \$500.00
- g. Late Application Fee: \$100.00

For purposes of subsection (c), a "local vendor" is defined as any person or entity whose principal business address is located within the corporate limits of the City of Marshalltown, Iowa, as of the date of application. Such status shall be verified by the RAGBRAI Committee at the time of application.

Section 4. Refundable Site Clean-Up Deposit.

All permitted vendors shall pay, at the time of application, a \$100.00 refundable deposit. If cleanup of the assigned vendor site is completed to the satisfaction of the Marshalltown RAGBRAI Committee's designated sanitation committee, the deposit will be refunded within thirty (30) days following the Event. Failure to adequately clean the assigned site shall result in forfeiture of the deposit.

Section 5. Vendor Booth Location.

A vendor who has been granted a permit pursuant to this Ordinance shall locate its temporary sale facility within city limits at a location, and only at that location, as determined by the official Marshalltown RAGBRAI Committee. No vendor shall relocate without prior written authorization from the RAGBRAI Committee.

Section 6. Non-Glass Containers.

To promote public safety during RAGBRAI, all beverages, both alcoholic and nonalcoholic, sold in Marshalltown, Iowa, by any vendor, business, or alcohol licensee to be consumed outside shall be sold in non-glass containers on July 22, 2026. Any sales of beverages by an alcohol license holder, or business, for consumption outside the permitted premises shall not be served in glass containers. This prohibition applies to all outdoor areas within the city limits for the duration of this Ordinance.

Section 7. Open Container - Temporary Waiver.

The City of Marshalltown's ordinance prohibiting the public consumption and open containers of alcoholic beverages, including the restrictions set forth in Municipal Code § 130.030(B) (Open Containers on Public Ways) and § 93.007 (Alcoholic Beverages in Parks), is hereby temporarily suspended city-wide during the period this Ordinance is in effect, as set forth in Section 18 herein. During this period, persons of legal drinking age may possess and consume alcoholic beverages in

open containers on any public sidewalk, street, alley, parking lot, city park, or park road , subject to all applicable state law and to the non-glass container requirement set forth in Section 6 of this Ordinance. Open containers will remain prohibited within a motor vehicle. Nothing herein shall be construed to authorize the public consumption of alcoholic beverages by persons under the legal drinking age. Law enforcement retains full authority to enforce all applicable state laws pertaining to intoxication, public disturbance, and underage consumption throughout the effective period of this Ordinance.

Section 8. Existing Alcohol License Holders - No Expansion.

Businesses holding an existing Iowa alcohol license as of the date of passage of this Ordinance may continue to operate within the terms, conditions, and physical boundaries of their currently approved license. No existing alcohol license holder shall be permitted to expand the physical area, premises, or scope of their licensed activity beyond what is expressly authorized in their current license as of the date this Ordinance is passed. Businesses with an existing licensed outdoor service area may operate within that area consistent with their current license.

This Section is intended to ensure that no business uses RAGBRAI as an occasion to obtain an expansion or modification of its existing license or permit outside the normal review process. Any request for temporary expansion of service area, license type, or licensed premises for July 22, 2026 shall be denied during the effective period of this Ordinance.

Section 9. Health Regulations.

A person issued a commercial, local, or non-profit vendor booth permit pursuant to this Ordinance shall comply with the Iowa Department of Health and Iowa Department of Inspections, Appeals and Licensing rules and regulations, including obtaining all appropriate permits, pertaining to the sale and dispensing of food and beverages for consumption on or near the permitted premises.

Section 10. Shower Vendor Permits.

Any person or entity seeking to operate a temporary shower facility in connection with the RAGBRAI Event on July 22, 2026, must obtain a Shower Vendor Permit from the Marshalltown RAGBRAI Committee. The fee for such a permit shall be \$500.00. Shower vendor facilities shall be located at a site designated by the RAGBRAI Committee and shall comply with all applicable health, sanitation, and plumbing requirements. The RAGBRAI Committee shall have sole discretion to approve or deny shower vendor permit applications.

Section 11. Application Deadline and Late Fees.

All applications for permits pursuant to this Ordinance must be received by the Marshalltown Area Chamber of Commerce no later than May 31, 2026. Applications received after this date are not guaranteed approval and shall be subject to a \$100.00 late application fee in addition to any applicable permit fees. The Marshalltown RAGBRAI Committee reserves the right to decline late applications based on space limitations, logistical constraints, or other reasonable grounds.

Section 12. Electrical Service.

Electrical access is available on a limited basis and is subject to availability at the designated vendor location. The fee for electrical access shall be \$150.00 per connection. The RAGBRAI Committee shall determine whether electrical access is available for any given vendor site.

Additional charges may apply if electrical needs exceed basic access. The City is not obligated to create new electrical access points as part of this Ordinance.

Section 13. Declining Permit.

The Marshalltown RAGBRAI Committee shall have sole discretion to approve all permits issued pursuant to this Ordinance and may decline to issue a permit for any reason consistent with applicable law, provided, however, that no applicant for a permit shall be denied based upon the race, creed, color, sex, age, or national origin of the applicant.

Section 14. Right-of-Way Control.

For the duration of the effective period of this Ordinance, as set forth in Section 22, the Marshalltown RAGBRAI Committee, in coordination with the Marshalltown Area Chamber of Commerce, is hereby granted authority over the use and management of designated City rights-of-way within the Festival Area as delineated in the 2026 Overnight Town Agreement. The RAGBRAI Committee shall have authority to determine the placement and operation of vendor booths, temporary facilities, signage, and other Event-related structures within the designated right-of-way. No person shall occupy, use, or operate within the designated right-of-way during the effective period of this Ordinance without the express written authorization of the Marshalltown RAGBRAI Committee.

This authority does not transfer any permanent rights over public property and is strictly limited to the effective dates of this Ordinance.

Section 15. Use of City-Owned Property for Vendor and Expo Activities.

The following City-owned properties are hereby made available to the Marshalltown RAGBRAI Committee for use as vendor and expo areas in connection with the Event on July 22, 2026, subject to the terms and conditions of this Ordinance and the 2026 Overnight Town Agreement:

- a. 2 W Main Street
- b. 102-104 W Main Street
- c. 15 S 1st Street
- d. 110 W Main Street
- e. 101 W Main Street

In addition, City-owned parking lots located within the downtown core, generally defined as the area bounded by 3rd Avenue to the east, 3rd Street to the west, one block north of State Street to the north, and Linn Street to the south, are hereby made available to the Marshalltown RAGBRAI Committee for use as vendor, expo, and Event support areas during the effective period of this Ordinance.

The RAGBRAI Committee shall have authority to determine the layout, placement, and operation of vendor booths, temporary structures, and Event-related facilities on all properties described in this Section. No person shall occupy or operate within any of these properties during the effective period of this Ordinance without the express written authorization of the Marshalltown RAGBRAI Committee. The availability of these properties for Event use does not transfer any permanent rights and is strictly limited to the effective dates of this Ordinance.

Section 16. Parking Enforcement - Temporary Suspension.

All parking time limits, and parking enforcement regulations applicable to City-owned parking lots and on-street parking within the downtown core, as defined in Section 16 of this Ordinance, are hereby temporarily suspended during the effective period of this Ordinance. No parking citations shall be issued within the defined downtown core for violations of time-limit parking requirements during the effective period of this Ordinance. Standard parking enforcement shall resume upon expiration of this Ordinance at 12:00 p.m. (noon) on July 23, 2026.

This suspension does not apply to parking regulations prohibiting the blocking of fire lanes, fire hydrants, accessible parking spaces, or other public safety-related restrictions, which shall remain in full effect throughout the duration of the Event.

Section 17. Bicycle Ordinance - Temporary Suspension.

Effective July 22, 2026, beginning at 5:00 a.m. and continuing through July 23, 2026, at 12:00 p.m. (noon), the provisions of Municipal Code § 73.015 through 73.019 (Bicycles and Skateboards), including but not limited to the prohibitions on bicycle use on public sidewalks in the business district and the equipment and operational requirements set forth therein, shall be temporarily suspended and shall not be enforced, except at the discretion of the Marshalltown Police Department. This suspension is intended to accommodate the safe passage and movement of RAGBRAI participants throughout the City of Marshalltown during the Event.

Section 18. Motorized Vehicles - Restrictions and Temporary Waivers.

The prohibition on all-terrain vehicles and off-road utility vehicles set forth in Municipal Code § 73.003 shall remain in full effect throughout the Event, except as specifically authorized by the City Council or its designee for Event-related operational purposes.

The use of motorized vehicles such as scooters, ATVs, UTVs, and similar conveyances is prohibited in Event venue areas and designated right-of-way, as determined by the Marshalltown RAGBRAI Committee, unless specifically authorized in writing by the Committee or the Chief of Police. This restriction does not apply to emergency vehicles, law enforcement, or City personnel acting in their official capacity.

The restriction limiting golf car operation to sunrise-to-sunset hours, as set forth in Municipal Code § 73.081(D), is hereby temporarily suspended during the effective period of this Ordinance to allow for operational use of golf cars by authorized Event personnel and vendors beyond sunset. All other provisions of § 73.081 governing golf car operation on city streets shall remain in effect.

Section 19. Park Hours - Temporary Suspension.

The park closing hours established in Municipal Code § 93.006(A), which restrict public use of municipal parks between 11:30 p.m. and 6:00 a.m., are hereby temporarily suspended during the effective period of this Ordinance to accommodate RAGBRAI Event operations, including campground access and overnight activities associated with the Event. This suspension applies to parks and park areas designated as part of the official Festival Area or campground as delineated in the 2026 Overnight Town Agreement. The Parks and Recreation Director retains authority to restrict access to specific park areas within this period as necessary for safety or operational purposes.

Section 20. Camping - Temporary Authorization.

The camping provisions of Municipal Code § 93.001, and the general prohibition on camping in parks other than at designated sites, are hereby temporarily modified for the duration of the effective period of this Ordinance to permit RAGBRAI-related camping in areas designated by the Marshalltown RAGBRAI Committee and approved by the Director of Parks and Recreation in connection with the Event. Camping fee and permit requirements under § 93.001(D) shall remain in effect unless specifically waived by the Director of Parks and Recreation for Event-designated campgrounds. The Director of Parks and Recreation retains authority to impose conditions on camping activities necessary to prevent damage to park areas.

Section 21. Street Closings.

During the effective dates of this Ordinance any City of Marshalltown employee, or those acting at their direction, may place barricades or roadblocks in any City street, alley, or roadway to redirect vehicular traffic in order to enhance the proper and safe flow of bicycle and vehicular traffic within the City limits of the City of Marshalltown.

Section 22. Effective Period.

The provisions of this Ordinance shall be in effect upon passage by the Marshalltown City Council and shall remain in effect through 12:00 p.m. (noon) on July 23, 2026, at which time all streets shall be reopened and all standard City ordinances temporarily suspended or modified hereunder shall be reinstated in full.

Section 23. Nuisance.

The sale of food or goods, or the erection of a temporary facility for the sale of food or other merchandise, without a required permit on July 22, 2026, is a violation of this Ordinance and shall be considered a nuisance. If such a nuisance is determined to exist by the City of Marshalltown, an emergency abatement procedure is hereby authorized and may be executed by any peace officer, authorized City employee, or those acting at their direction, by dismantling and removing the nuisance without notice.

Section 24. Violations - Penalties.

Selling or supplying food or goods to the public without a required vendor booth permit on July 22, 2026, when such a permit is required by this Ordinance, is a violation of this Ordinance. The Marshalltown RAGBRAI Committee may, at its sole discretion, issue a permit to such person subject to receipt of all applicable booth fees, any applicable late fee, and an additional penalty fee of \$500.00. Furthermore, any violation of this Ordinance shall constitute a municipal infraction, and any civil penalties may likewise be assessed and enforced as provided by applicable law and the City of Marshalltown's Code of Ordinances.

Section 25. Authority and Appeals.

Any and all issues and appeals regarding this Ordinance shall be brought to the Marshalltown RAGBRAI Committee and the City of Marshalltown for resolution. The Committee and City shall cooperate in good faith to resolve any such matter in a timely manner consistent with the operational needs of the Event.

Section 26. Repealer.

All previous ordinances or parts of such ordinances in conflict with the provisions of this Ordinance are hereby repealed for the effective period of this Ordinance.

Section 27. Severability Clause.

If any section, provision, or part of this Ordinance shall be adjudged to be invalid or unconstitutional, such adjudication shall not affect the validity of the Ordinance as a whole, or any section thereof, not adjudged invalid or unconstitutional.

Section 28. When Effective.

This Ordinance shall be in full force and effect from and after its passage, approval, and publication as provided by law.

Passed this ____ day of _____, 2026, and signed this ____ day of _____, 2026.

CITY OF MARSHALLTOWN, IOWA

Mike Ladehoff, Mayor

ATTEST:

Alicia Hunter, CMC, City Clerk

I, Alicia Hunter, City Clerk of the City of Marshalltown, Iowa, do hereby certify that the foregoing ORDINANCE was passed and approved by the City Council of the City of Marshalltown, Iowa, on the ____ day of _____, 2026, and was published in the Marshalltown Times-Republican, a newspaper of general circulation in the City of Marshalltown, Iowa, on the ____ day of _____, 2026.

Alicia Hunter, City Clerk



**MARSHALLTOWN
MORE THAN EVER**

**Mike Ladehoff, Mayor
Carol Webb, City Administrator
24 North Center Street
Marshalltown, IA 50158
PH 641.754.5701 • FX 641.754.5717**

To: Mayor and City Council
From: Alicia Hunter, City Clerk, Carol Webb, City Administrator
Meeting Date: May 11, 2026
Re: Ordinance 15121 Amending the Code of Ordinances of the City of Marshalltown, Iowa, by Adding a New Chapter 111 Establishing Requirements for Outdoor Seating Areas on Public Property - First Reading

Strategic Plan Objective:

This item does not directly address a strategic objective, but it does support the City's goals related to downtown vitality, business support, public safety, accessibility, and responsible management of public property and rights-of-way.

Recommended:

Staff recommends that the City Council approve the first reading of an ordinance establishing requirements for outdoor seating areas on public property in the Marshalltown Central Business District and 13th Street District.

Budget Impact:

The ordinance itself does not create a significant budget impact. The proposed process may require limited staff time to review applications, site plans, insurance documentation, and compliance with the ordinance. Any application or license fee may be established separately by resolution of the City Council to help offset administrative costs associated with processing and reviewing applications.

Description/Background:

At the April 13, 2026, City Council meeting, staff presented a proposed ordinance to establish an outdoor seating license for businesses operating outdoor seating areas on public property in the Marshalltown Central Business District and 13th Street District. The ordinance intended to support outdoor dining and business activity while also establishing standards to protect pedestrian access, accessibility, public safety, maintenance responsibilities, insurance coverage, and the City's ability to use and manage public property.

During the meeting, public comments were provided indicating that the original proposal appeared excessive, particularly because it required City Council authorization for each outdoor seating area. Following the discussion, the Council directed staff to work with affected business

owners and revise the ordinance to establish an administrative approval process.

The ordinance now presented for first reading reflects that direction. Under the revised ordinance, businesses would still be required to obtain an outdoor seating license before placing or operating outdoor seating on public property. However, rather than requiring individual City Council approval for each license, the City Administrator or designee would be authorized to approve, approve with conditions, or deny applications administratively. The City Council would serve as the appeal body for denials, suspensions, or revocations of licenses.

Since the April 13 discussion, staff revised the proposed ordinance to create a simpler administrative approval process. Staff also shared the revised version with the Marshalltown Central Business District and an impacted business owner and received positive feedback on the revised approach. This feedback indicates that the revised ordinance better balances the City’s need to protect public property, pedestrian access, accessibility, and public safety with the desire to maintain a practical and business-friendly process for outdoor seating areas.

Summary of Proposed Ordinance

The proposed ordinance would require businesses to obtain an outdoor seating license before operating outdoor seating areas on public property in the Marshalltown Central Business District or 13th Street District. The license would be approved administratively by the City Administrator or designee, with appeals heard by the City Council.

Applicants would be required to provide basic business information, property owner authorization if needed, a site plan or sketch, and proof of insurance. The City would review applications for pedestrian access, accessibility, public safety, and potential conflicts with entrances, utilities, drainage, City operations, or other public uses.

Licensed outdoor seating areas would be required to maintain a clear pedestrian route, remain clean and well-maintained, avoid creating safety hazards or nuisances, and comply with applicable building, fire, health, alcohol, and accessibility requirements. Licenses would be valid for three years, and outdoor seating would generally be allowed seasonally from April 1 through November 1, unless otherwise approved by the City.

Policy Considerations

Outdoor seating can contribute positively to the downtown environment by supporting restaurants, bars, cafés, and other food and beverage businesses, while also helping create a more active and inviting streetscape. At the same time, these areas are located on public property and may affect pedestrian movement, accessibility, emergency access, City maintenance activities, utilities, and adjacent properties.

The proposed ordinance is intended to strike a balance between those interests. It establishes clear expectations for businesses using public property while also creating a more flexible and business-friendly administrative process than the version previously discussed by Council. The revised process maintains City oversight and public safety protections without requiring each

individual license to return to the City Council for approval.

Attachments:

1. 2026-05-11_ORD 15121_CH 111 Outdoor Seating Areas on Public Property

AN ORDINANCE AMENDING THE CODE OF ORDINANCES OF THE CITY OF MARSHALLTOWN, IOWA, BY ADDING A NEW CHAPTER ESTABLISHING REQUIREMENTS FOR OUTDOOR SEATING AREAS ON PUBLIC PROPERTY

BE IT ORDAINED BY THE CITY COUNCIL OF THE CITY OF MARSHALLTOWN, IOWA:

Section 1. The Code of Ordinances of the City of Marshalltown, Iowa, is hereby amended by adding a new Chapter 111, entitled Outdoor Seating Areas on Public Property, to read as follows:

**CHAPTER 111
OUTDOOR SEATING AREAS ON PUBLIC PROPERTY**

111.010 Purpose.

The purpose of this Chapter is to allow outdoor seating areas adjacent to food and beverage establishments on public property in a manner that supports business activity while protecting pedestrian access, public safety, accessibility, and the City's use of the public right-of-way.

111.020 Definitions.

For purposes of this Chapter, the following terms shall have the meanings stated:

Outdoor seating area means an area located on public property adjacent to a business and used for tables, chairs, and related furnishings for the consumption of food or beverages.

License means an outdoor seating license issued by the City authorizing operation of an outdoor seating area on public property.

Operator means the person or entity operating the business using the outdoor seating area.

111.030 License Required.

No person or entity shall operate a business that provides outdoor seating on public property for the purpose of consuming food or beverages without first obtaining a valid outdoor seating license from the City.

111.040 Areas Allowed.

Outdoor seating areas on public property shall be permitted only within the Marshalltown Central Business District and the 13th Street District.

111.050 Application.

Applications for an outdoor seating license shall be submitted on a form provided by the City and shall include the following:

- A. The name and contact information of the applicant and business operator;
- B. Written authorization from the property owner, if different from the applicant;

- C. A site plan or sketch showing the proposed seating area, adjacent building frontage, pedestrian route, entrances, and nearby obstructions;
- D. Proof of insurance satisfactory to City Code Section 10.009; and
- E. Any other information reasonably required by the City to evaluate the application for compliance with this Chapter.

111.060 Approval Authority.

- A. The City Administrator, or designee, may approve, approve with conditions, or deny an application for an outdoor seating license.
- B. In reviewing an application, the City shall consider whether the proposed outdoor seating area:
 - 1. Provides adequate pedestrian access;
 - 2. Protects public safety and accessibility;
 - 3. Does not interfere with entrances, utilities, drainage, or City operations; and
 - 4. Complies with applicable City Code and other applicable law.
- C. The City may impose reasonable conditions necessary to protect public health, safety, accessibility, and welfare.
- D. The City Council shall hear appeals from denials, suspensions, or revocations of licenses.

111.070 General Standards.

All licensed outdoor seating areas shall comply with the following requirements:

- A. A clear and unobstructed pedestrian route of at least five feet shall be maintained on the public sidewalk, except where an existing publicly owned or permitted obstruction makes full compliance impracticable, in which case the City Administrator or designee may approve a reduced width that still provides a reasonably safe and accessible route.
- B. The outdoor seating area shall not obstruct:
 - 1. Building entrances or exits;
 - 2. Fire lanes or fire protection equipment;
 - 3. Utilities or utility access;
 - 4. Stormwater drainage; or
 - 5. Sight lines needed for pedestrian or traffic safety.
- C. The operator shall keep the outdoor seating area and the immediately surrounding area clean and free of litter during all hours of operation.
- D. All furniture, barriers, and related improvements shall be maintained in good condition.
- E. The operator shall be responsible for damage to public property caused by the outdoor seating area.
- F. All kitchen equipment, food preparation equipment, and refuse containers used to service the outdoor seating area shall be located inside the principal building unless otherwise approved by the City.
- G. No extension cords shall be allowed across sidewalks or pedestrian routes unless expressly approved by the City as part of the license.
- H. The outdoor seating area shall comply with applicable building, fire, health, alcohol, and accessibility requirements.

111.080 Insurance and Use of Public Property.

- A. As a condition of approval, the operator shall provide proof of insurance in an amount and form acceptable to the City. If the outdoor seating area is licensed as an outdoor service area under an alcohol license, the operator shall provide the required dram shop insurance for the outdoor service area as part of the alcohol license requirements.
- B. The operator shall agree to indemnify and hold harmless the City from claims arising out of the operator's use of the outdoor seating area on public property.
- C. Issuance of a license under this Chapter does not create a property right in the public right-of-way or other public property.

111.090 Term.

- A. An outdoor seating license shall be valid for three years unless earlier suspended or revoked.
- B. A license may be renewed upon application and continued compliance with this Chapter.
- C. Outdoor seating areas on public property shall not be installed before April 1 and shall be removed no later than November 1 unless otherwise approved by the City Administrator or designee.

111.100 Suspension or Revocation.

- A. The City Administrator, or designee, may suspend or revoke an outdoor seating license for any of the following reasons:
 - 1. Violation of this Chapter or the conditions of approval;
 - 2. Violation of applicable law;
 - 3. Creation of a safety hazard, health hazard, or public nuisance; or
 - 4. A substantial public need to use the public property for construction, maintenance, utilities, events, or another valid public purpose.
- B. Except in cases of emergency or immediate threat to public health or safety, the City shall provide written notice of the violation and a reasonable opportunity to cure before revoking a license.
- C. The operator may appeal a suspension or revocation to the City Council.

Section 2. Repealer. All ordinances or parts of ordinances in conflict with the provisions of this Ordinance are hereby repealed.

Section 3. Severability. If any section, provision, or part of this Ordinance is adjudged invalid or unconstitutional, such adjudication shall not affect the validity of this Ordinance as a whole or any section, provision, or part thereof not adjudged invalid or unconstitutional.

Section 4. When Effective. This Ordinance shall be in effect after its final passage, approval, and publication as provided by law.

Passed this _____ day of _____, 2026, and signed this _____ day of _____, 2026.

CITY OF MARSHALLTOWN, IOWA

Mike Ladehoff, Mayor

ATTEST:

Alicia Hunter, CMC, City Clerk

I, Alicia Hunter, City Clerk of the City of Marshalltown, Iowa, do hereby certify that the foregoing ORDINANCE was passed and approved by the City Council of the City of Marshalltown, Iowa, on the _____ day of _____, 2026, and was published in the Marshalltown Times-Republican, a newspaper of general circulation in the City of Marshalltown, Iowa, on the _____ day of _____, 2026.



**MARSHALLTOWN
MORE THAN EVER**

**Mike Ladehoff, Mayor
Carol Webb, City Administrator
24 North Center Street
Marshalltown, IA 50158
PH 641.754.5701 • FX 641.754.5717**

To: Mayor and City Council
From: Ben Daleske, Engineer
Meeting Date: May 11, 2026
Re: Center St Viaduct - Railing Option

Strategic Plan Objective:

Continually improve and sustain the City's infrastructure, organization, and services.

Recommended:

Provide direction to Engineering Staff on whether to proceed with a contract amendment with Boulder Construction for the Iowa DOT BHM-4797(629)--8K-64 Center Street Viaduct Rehabilitation Project (STR21002) in the amount of \$109,050 for replacement of the existing railing with new black vinyl-coated chain link fencing and posts in lieu of cleaning and painting the existing fencing per contract.

Budget Impact:

Based on the project costs broken down, as follows, we have sufficient funds allocated for this request.

Expenses:

Item	Vendor	Cost	Notes
Conceptual Engineering	Stanley	\$ 121,400.00	Contract Completed / Paid 12/14/21
Design Engineering	Stanley	\$ 222,400.00	
UP RR Preliminary Reimbursement Agreement	UP Railroad	\$ 25,000.00	
Material for Temporary Finger Joint Welding	Central Iowa Machine	\$ 6,036.00	Contract Completed - Paid 03/10/23
Design Engineering Amend	Stanley	\$ 33,500.00	Executed 05/29/24
UPRR Permit	UP Railroad	\$ 1,000.00	Agreement executed 10/17/25
UPRR Construction Reimbursement Agreement	UP Railroad	\$ 90,000.00	Estimate Council Approved 10/27/25. UPRR bills actual.
Construction Engineering Assistance	Stanley	\$ 104,600.00	Limited Construction Engineering Support Scope
Steel Fabrication Inspection	Pennoni	\$ 57,200	Cost Estimate
Outside Construction	TBD	\$ 238,200.00	Will require certified

Engineering, Inspection, and Testing Materials			fabrication inspectors, material testers, etc. City staff will do what we can. Shown as place holder.
Construction	Boulder Construction	\$ 4,049,299.00	
Change Order #1	Boulder Construction	\$160,461.00	Additional Concrete Repairs
Construction Contingency	TBD	\$ 135,418.00	Recommend 10% Carry
Proposed New Railing	Boulder	\$ 109,050.00	
TOTAL		\$ 5,353,565.00	

Revenue:

Fund / Source	Revenue	Notes
Fund 110 – Road Use Tax (FY21)	\$ 60,700.00	
Fund 110 – Road Use Tax (FY22)	\$ 60,700.00	
Fund 363 – 2021 GO Bond	\$ 218,592.03	11/03/21 Bond Sale, w several bond swaps
Fund 354 – Police & Fire Bond	\$ 62,272.00	Bond Swaps to Utilize P/F Bond
Fund 365 – 2023 GO Bond	\$ 3,451,300.97	Bond Swaps & Additional allocation provided from SIP
City Bridge Grant Funds	\$ 1,500,000.00	
TOTAL	\$ 5,353,565.00	

Description/Background:

As part of the Iowa DOT BHM-4797(629)--8K-64 Center Street Viaduct Rehabilitation Project (STR21002), the project originally included cleaning and painting of the existing historic railings/fencing. During prior project discussions in 2022, the City also evaluated a potential alternate option to replace the existing fencing with new chain link fencing; however, at that time, Council direction was to retain and repaint the original railing system.

In February 2026, City Engineering Staff and Boulder Construction revisited the possibility of fence replacement due to the thought that replacement of the fencing would potentially be a cost deduct to the project as the railroad requires containment of sandblasting / painting the existing railing. There have also been discussions on the condition of the existing fencing, the low height of the fence not meeting UPRR requirements, and associated maintenance considerations. Discussions included potential attachment methods, railroad safety requirements, fence heights, chain link mesh sizing, and constructability.

Engineering Staff coordinated with Union Pacific Railroad (UPRR) regarding fencing height requirements over the railroad corridor. Based on those discussions, the proposed replacement fencing would generally consist of 10-foot-tall black vinyl-coated chain link fencing in areas over the railroad tracks, with shorter 4-foot fencing sections in limited approach/vaulted areas

where allowable. The proposed fencing would utilize existing attachment locations where feasible to minimize impacts to the bridge deck and reduce additional field preparation and painting needs.

Following coordination between the City and Boulder Construction, the proposed replacement fencing scope includes approximately:

- 2,840 linear feet of 4-foot-tall fencing,
- 660 linear feet of 10-foot-tall fencing,
- Black vinyl-coated chain link material with 2-inch mesh openings, and
- New posts mounted utilizing the existing attachment locations where feasible.

Boulder provided that estimated additional cost to replace the existing fencing, rather than proceed with cleaning and painting of the current fencing, is \$109,050.

Attachments:

1. Bridge Drawing - Vault Area
2. Bridge Drawing - Side Mount
3. Boulder - Fencing Email

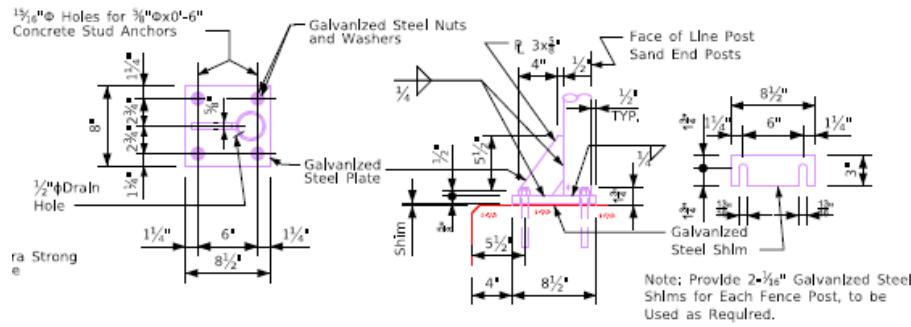

BASE PLATE DETAILS FOR NEW PIPE CONNECTION TO CONCRETE

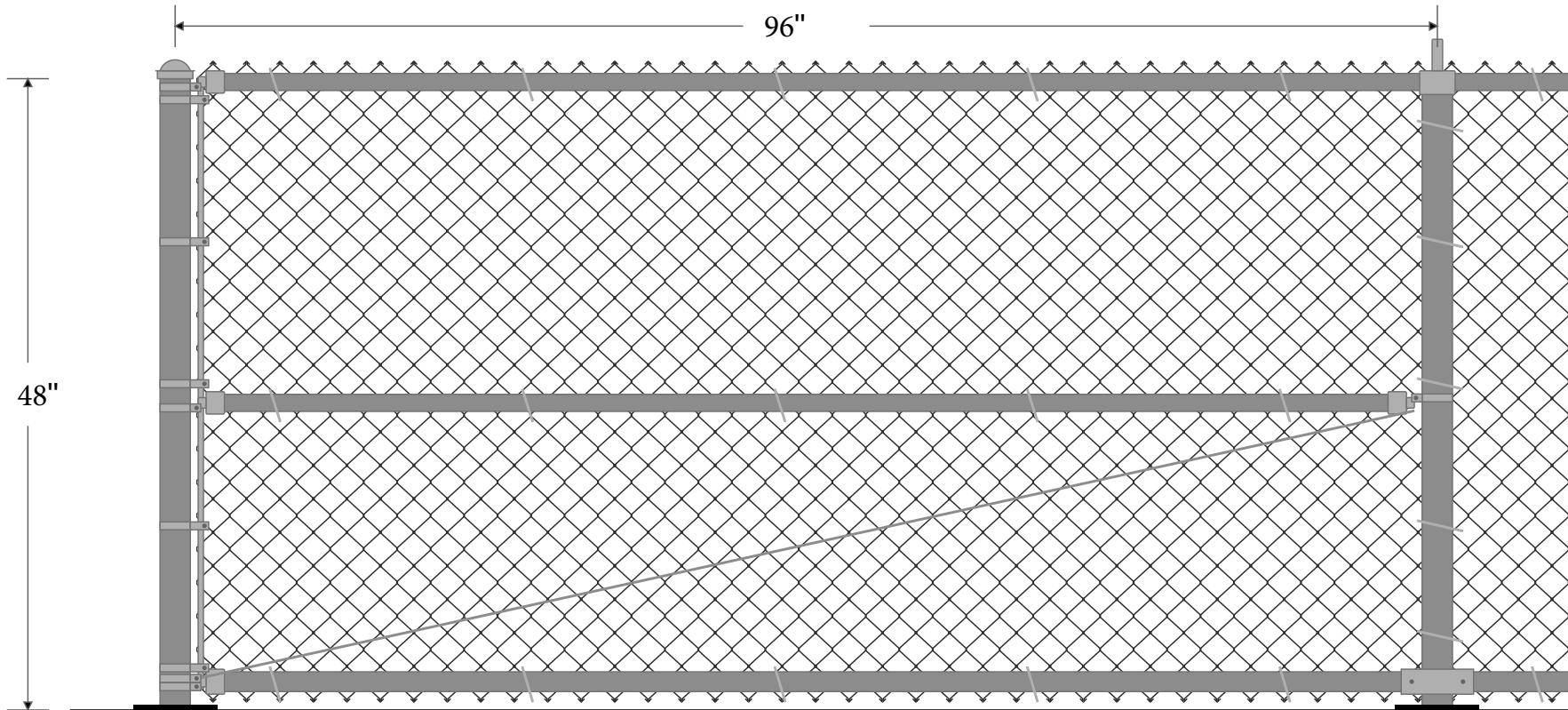

48" tall chain link fabric with knuckle / knuckle and 2" mesh size Black Vinyl Class 2B.

Specifications:

49" tall, Sch40 BLK 2 7/8" diameter terminal post with 8" diameter post base plate.

46" tall, Sch40 BLK 2 7/8" diameter line post with 8" diameter post base plate

Top of fence has Sch40 BLK 1 5/8" diameter top rail.

Bottom of fence has Sch40 BLK 2 3/8" diameter bottom rail.

Fence is braced with Sch40 BLK 2 3/8" diameter brace.

Line post spacing: 96" on center.

Tie wire spacing is every 12" on rails, bracing and posts.

Rails are attached with boulevard clamps.

5/8" x 6" Galvanized Anchors

Taves Contracting Services
201 LIBERTY DR SE
Cedar Rapids, IA 52403
1(319) 414-3499

Marshaltown Bridge



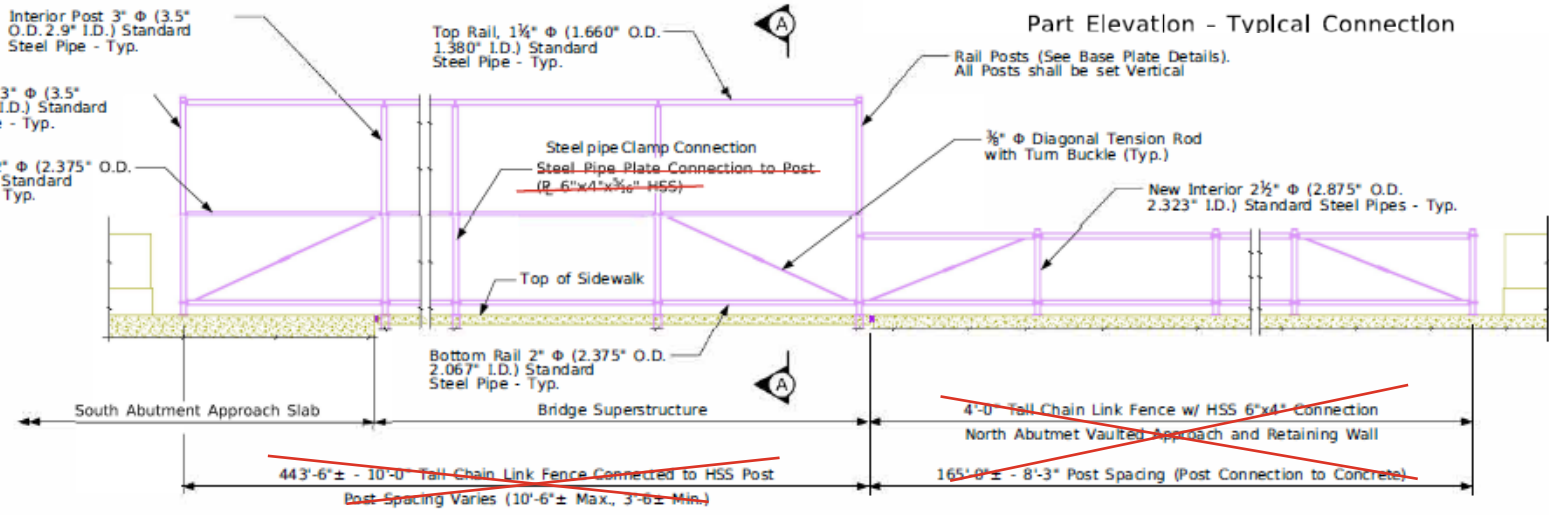
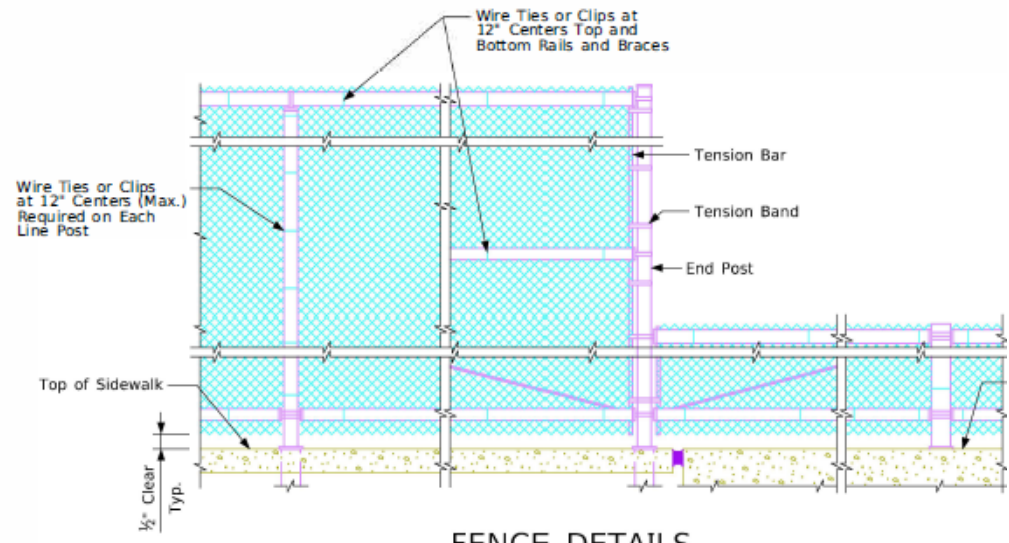
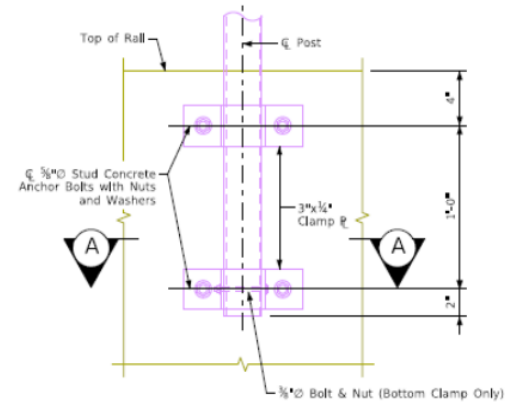
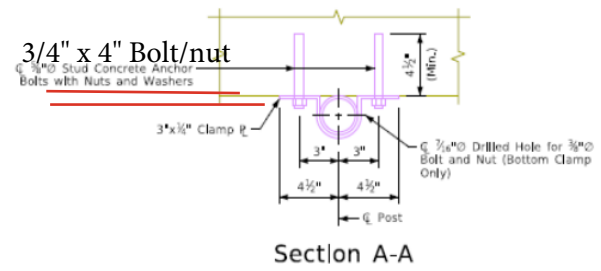

48 & 120" tall chain link fabric with knuckle / knuckle and 2" mesh size. BLK Vinyl Class 2B

Specifications:

72" & 144" tall, BLK Sch40 2 7/8" diameter terminal post with 8" diameter post base plate.

72" & 144" tall, BLK Sch40 2 7/8" diameter line post with 8" diameter post base plate

Top of fence has BLK Sch40 1 5/8" diameter top rail.

120" tall Fence has Middle Rail BLK Sch40 1-5/8"

Bottom of fence has BLK Sch40 2 3/8" diameter bottom rail.

Fence is braced with BLK Sch40 1 5/8" diameter brace.

Line post spacing: 96" on center.

Tie wire spacing is every 12" on rails bracing & posts.

Rails are attached with boulevard clamps.

4' tall fence to utilize 2 clamps each posts

10' tall fence to utilize 3 clamps each post

All clamps to utilize existing holes



Taves Contracting Services
 201 LIBERTY DR SE
 Cedar Rapids, IA 52403
 1(319) 414-3499

Ben Daleske

From: Luke Kjormoe <luke@bouldercontracting.net>
Sent: Tuesday, April 28, 2026 9:38 AM
To: Benton Daleske
Cc: Heather Thomas
Subject: Fence Pricing
Attachments: CLFWMB-3 _Spe.pdf; Bridge Drawing plated.pdf; Bridge Drawing - side mount.pdf

CAUTION: This email originated from outside of the City of Marshalltown. Do not click links or open attachments unless you recognize the sender and know the content is safe.

Ben,

To remove and replace the current fencing with 4' and 10' chain link the additional net cost would be **\$109,050**. Also, we propose adding 15 working days to the contract. It is quicker to blast and paint than to remove and replace.

I have attached a couple of sheets showing the brackets and the mounting plan. All fencing and posts will be powder-coated black.

My primary condition for this pricing is that Boulder does not have railroad protection accommodations built in, other than flagging. Taves plans to complete all work from the bridge deck. That said, if Benesch decides physical track protection is required, our pricing will need revision.

At this point, I think the city should evaluate this price and decide whether to move forward with it. Then we can decide how to address the potential UPRR concerns/requirements beyond flagging.

Please let me know what questions you have.

Thanks,

Luke Kjormoe
M: 319.269.8680
Boulder Contracting, LLC.